

# Stock Vertical Motors

Hardworking. Dependable. Unstoppable.

STOCK VHS | INTERNATIONAL DUTY |  
HIGH THRUST | NORMAL THRUST

**Nidec**

NIDEC MOTOR CORPORATION

*Countless Solutions. Expert Support.*



# Table of Contents

---

AGENCY APPROVALS AND LIMITED WARRANTY .....	i
GENERAL INFORMATION FOR INTEGRAL HORSEPOWER MOTORS ON VARIABLE FREQUENCY DRIVES (VFDS) .....	ii
MOTOR / INVERTER COMPATIBILITY .....	iii
WARRANTY GUIDELINES FOR INTEGRAL HORSEPOWER (IHP) MOTORS ON VARIABLE FREQUENCY DRIVES .....	iv
LIMITED WARRANTY .....	v
TERMS & CONDITIONS OF SALE .....	vi
CATALOG NUMBERING SYSTEM .....	vii
TYPICAL MOTOR CONSTRUCTION FEATURES .....	viii - ix
WPI VERTICAL HOLLOSHAFT® SINGLE PHASE STOCK MOTORS .....	P-1
WPI SINEWAVE OPTIMIZED® HOLLOSHAFT® STOCK MOTORS .....	P-2 - P-3
WPI INVERTER DUTY HOLLOSHAFT® STOCK MOTORS .....	P-4 - P-5
TEFC SINEWAVE OPTIMIZED® HOLLOSHAFT® STOCK MOTORS.....	P-6
TEFC INVERTER DUTY CORRO-DUTY® HOLLOSHAFT® STOCK MOTORS.....	P-7
WPI INTERNATIONAL DUTY HOLLOSHAFT® STOCK MOTORS .....	P-8
WPI NORMAL THRUST STOCK MOTORS .....	P-9
TEFC CORRO-DUTY® NORMAL THRUST STOCK MOTORS .....	P-10
TEFC CORRO-DUTY® VERTICAL C-FACE STOCK MOTORS.....	P-11 - P-12
STEADY BUSHING KITS .....	P13 - P14
CONVERSIONS AND ACCESSORIES INTRO AND PRICING GUIDELINES .....	C-1
CONVERSIONS AND ACCESSORIES QUICK PICK CHART .....	C-2 - C-3
CONVERSIONS AND ACCESSORIES DESCRIPTIONS AND ADDERS .....	C-4 - C-9
QUICK ENGINEERING FACTS .....	E-1
FORMULAS .....	E-2
LONG TERM STORAGE INFORMATION .....	E-3 - E-5
OPERATING CHARACTERISTICS VERTICAL HOLLOSHAFT® WPI PREMIUM EFFICIENT, SINEWAVE OPTIMIZED® .....	E-6
OPERATING CHARACTERISTICS VERTICAL HOLLOSHAFT® WPI INVERTER DUTY .....	E-7
OPERATING CHARACTERISTICS VERTICAL HOLLOSHAFT® TEFC PREMIUM EFFICIENT, SINEWAVE OPTIMIZED® .....	E-8
OPERATING CHARACTERISTICS VERTICAL HOLLOSHAFT® TEFC INVERTER DUTY CORRO-DUTY® .....	E-9
OPERATING CHARACTERISTICS VERTICAL HOLLOSHAFT® WPI PREMIUM EFFICIENT, INTERNATIONAL DUTY .....	E-10
OPERATING CHARACTERISTICS VERTICAL SOLID SHAFT NORMAL THRUST WPI PREMIUM EFFICIENT.....	E-11
OPERATING CHARACTERISTICS VERTICAL SOLID SHAFT NORMAL THRUST TEFC PREMIUM EFFICIENT, CORRO-DUTY® .....	E-12
OPERATING CHARACTERISTICS VERTICAL C-FACE TEFC PREMIUM EFFICIENT, CORRO-DUTY®.....	E-13 - E-14
DIMENSION PRINT INDEX .....	E-15
DRIVE COUPLING PART NUMBERS .....	E-16 - E-18
DIMENSION PRINTS .....	E-19 - E-50
CUSTOMER COMMENT FORM .....	A-1





# Agency Approvals and Limited Warranty

## Important Information

Nidec Motor Corporation has made every effort to ensure the integrity of the contents of this catalog. However, Nidec Motor Corporation cannot accept responsibility for errors that may have been caused by changing model/catalog numbers, or for typographical or clerical errors in the preparation of this catalog. The motor data and dimensions are provided for reference only. Certified dimensions and performance data will be furnished upon request. Prices are subject to change without notification.

Nidec Motor Corporation does not assume responsibility for the selection, use, or maintenance of any product. Responsibility for the proper selection, use and maintenance of any product within this catalog remains solely with the purchaser and end-user.

The contents of this publication are presented for informational purposes only, and while every effort has been made to ensure their accuracy, except for Nidec Motor Corporation's standard Limited Warranty stated herein, they are not to be constructed as warranties or guarantees, expressed or implied, regarding the products described herein or their use or applicability. Nidec Motor Corporation reserves the right to modify or improve the designs or specifications of such products at any time without notice.

The following is a list of Nidec Motor Corporation's U.S. trademarks for products and services in this catalog. The trademarks followed by the ® symbol are registered with the U.S. Patent and Trademark Office.

**ACCU-SERIES™**      **ALLGUARD®**      **BALLOMATIC®**      **CORRO-DUTY®**      **HOLLOSHAFT®**  
**INVERTER GRADE®**      **LUBRIPORT®**      **SINEWAVE OPTIMIZED®**      **TITAN®**      **U.S. MOTORS®**

† All marks shown within this document are properties of their respective owners.

## Agency Approvals

### ISO 9001:2015 Certified

By British Standards Institute of America

### CSA Group (CSA®†)

Formerly the Canadian Standards Association

CSA®† sets safety standards for motors and other electrical equipment used in Canada. The motors that meet the CSA®† standards display the CSA®† logo on the nameplate or display the cUR logo (indicating evaluation to CSA standards by UL).

### UL LLC (UL®†)

Formerly Underwriters Laboratories, Inc.

UL®† is an independent testing organization that sets safety standards for motors and other equipment and U.S. Motors® brand are UL®† component recognized.

## United States Department of Energy

All motors within this catalog that are required to comply with the United States Department of Energy's Efficiency regulation 10 CFR Section 431 Subpart B – electric motors, display the compliance certification number CC030A on the motor nameplate. Motors within the scope of 10CFR Section 431 Subpart X meet the requirements.

## Conformité Européenne European Community (CE Certification)

The CE marking indicates that the product complies with the essential requirements for health, safety, environmental and consumer protection. The CE mark can only be applied to non-hazardous location motors rated 1000 volts or less, frame 180 through 449, Dripproof and Totally Enclosed Fan Cooled enclosures. Many Nidec Motor Corporation motors can have the CE logo applied. For information on CE logo availability, contact your Nidec Motor Corporation representative.

## UL®† & CSA®† Listings

	UL®†		CSA®†	
	IHP	FHP	IHP	FHP
General Construction	E51488	E22922	191252	156060 %
Hazardous Location	E10336	E29183		
Thermal Protection	E38946	E10073		
Fire Pump	EX5189**	-	-	-
Electronic Protection (#)	-	E255002	-	-
Energy Efficiency Verified (&)	E51488	-	-	-

\*For details on VFD for these motors, refer to Suitability of IHP Motors on Variable Frequency Drives (VFD), page ii.

# cURus marked indicating evaluation for UL and CSA standards

& Verification for US DOE 10CFR Section 431 Subpart B and Natural Resources Canada C390

\*\* Fire pump certification appears in conjunction with UL and CSA General Construction

% File number LR2459 or LR63596 may appear on some product





# General Information for Integral Horsepower (IHP) Motors on Variable Frequency Drives (VFDs)

## Variable Frequency Drives (VFD)

A VFD is a type of controller used to vary the speed of an electric motor. The VFD takes a fixed AC voltage and frequency and allows it to be adjusted in order to get different speeds from the motor. Motor speed can be varied by changing the frequency of the input power waveform. The equation below shows how the frequency affects the speed of a three phase induction motor.

$$\text{Speed} = \frac{120 \times \text{Fundamental Input Frequency}}{\text{Number of Motor Poles}}$$

## How does a VFD work?

A VFD takes the fixed frequency and voltage sine wave from the power grid or power station and puts it through a few steps in order to allow the VFD user to vary the frequency and in turn control the motor speed. First it rectifies the AC power into DC Power. Because of this step, a term commonly used instead of VFD is inverter. This only describes one step of what the VFD does to the power waveform. Once rectified into a DC voltage the drive sends the power through a set of transistors or switches. These switches can take the DC waveform and by opening and closing at certain speeds and durations can create an output waveform that mimics the sine wave that is required to drive a three phase electric motor. The output wave form is known as a Pulse Width Modulation (PWM) waveform because the waveform is created by multiple pulses of the switches at short intervals.

### PULSE WIDTH MODULATION WAVEFORM

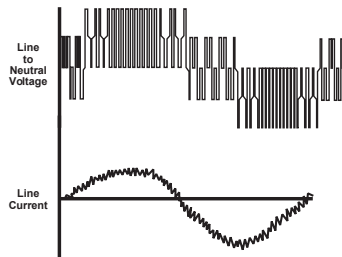

Figure 1 PWM Waveform

## What variables should be considered when deciding whether to power a motor with a VFD?

VFD compatibility with motors is complex. As a result, many variables must be considered when determining the suitability of a particular motor for use with a VFD. These variables include:

- Torque requirements (Constant or Variable)
- Speed Range
- Line / System Voltage
- Cable length between the VFD and the motor
- Drive switching (carrier) frequency
- Motor construction
- VFD dv/dt
- High temperatures or high humidity
- Grounding system

Wider speed ranges, higher voltages, higher switching frequencies, insufficient grounding and increased cable lengths all add to the severity of the application and, therefore, the potential for premature motor failure.

## How does a VFD affect the motor?

There are many things to consider when a motor is powered using a VFD or PWM power. When a motor is powered by a PWM waveform the motor windings very often see a large differential voltage, either from phase to phase or turn to turn. When the voltage differential becomes large enough it creates a reaction at the molecular level that converts available oxygen into O<sub>3</sub>. This phenomenon is called partial discharge or corona. This reaction creates energy in the form of light and heat. This energy has a corrosive effect on the varnish used to protect the motor windings. PWM waveforms can also magnify shaft voltages which lead to arcing across the bearing and causing premature bearing failure. Corrective action must be taken to mitigate these issues that arise when using an electric motor with a VFD.

## How do I protect the motor?

Nidec Motor Corporation (NMC) has developed specific motor designs to decrease the harmful effects that a VFD can have on a motor. NMC's INVERTER GRADE<sup>®</sup> insulation system is the first line of defense against corona and phase to phase faults that can be common when a motor is powered using a PWM waveform. The INVERTER GRADE<sup>®</sup> insulation system is standard on all of NMC's Inverter Duty products. Along with the INVERTER GRADE<sup>®</sup> insulation, thermostats are installed as a minimum protection against over heating the motor. Special consideration must also be given to bearings in motors powered by VFD's. In order to create a low resistance path to ground for built up shaft voltages a shaft grounding device can be used. On larger horsepower motors an insulated bearing system should be used in conjunction with the shaft grounding device when installed, to force the stray shaft voltages to ground. The bearing failures are more prominent on motors with thrust handling bearings. NMC has created an Inverter Duty vertical motor line that not only uses the INVERTER GRADE<sup>®</sup> insulation system, but that also comes standard with a shaft grounding device. On motors that are 100 HP and greater the thrust bearing is also insulated for additional protection.

## What does "Inverter Duty" mean?

An Inverter Duty motor should describe a motor that helps mitigate potential failure modes of a motor that is powered by a VFD. Inverter duty motor windings should be able to withstand the voltage spikes per NEMA MG1 Part 31.4.4.2 and protect against overheating when the motor is run at slow speeds. On thrust handling bearings, it is apparent that the bearings require additional protection. Inverter Duty vertical motors should have a shaft grounding device to protect the motor bearings from fluting due to voltage discharge through the bearing. On larger motors (100HP and larger) the shaft should also be electrically isolated from the frame in order to aid the shaft grounding ring in discharging the shaft voltages to ground.

\* This information applies only to Integral Horsepower (IHP) motors as defined on the Agency Approval page, under UL<sup>®</sup> & CSA<sup>®</sup> listings where indicated.



# Motor / Inverter Compatibility

## Thermal Overloads and Single Phase Motors

Motors with thermal overloads installed may not operate properly on a VFD. The current carrying thermal overload is designed for sine wave power. Operation on a VFD may cause nuisance tripping or potentially not protect the motor as would be expected on line power. Thermostats or thermistors installed in the motor and connected properly to the VFD may provide suitable thermal overload protection when operating on a VFD. (consult codes for installation requirements)

Single phase motors and other fractional horsepower ratings are not designed to be operated on a VFD. Within Nidec Motor Corporation standard products, all motors NEMA<sup>®†</sup> 48 frame (5.5" diameter) and smaller are not suitable for VFD applications. Three phase 56 and 143/145 frame applications should be noted on the catalog price page; or if in doubt ask a Nidec Motor Corporation technical representative for recommendations on compatibility with a VFD.

## Slow Speed Motors

Motors with a base design of slower than six poles require special consideration regarding VFD sizing and minimizing harmonic distortion created at the motor terminals due to cable installation characteristics. Additional external PWM waveform filters and shielded motor cables designed for PWM power may be required to provide acceptable motor life. Harmonic distortion on the output waveform should be kept to a minimum level (less than 10%) mismatch impedance.

## 690V Applications

Motors that are rated for 690VAC and that will be powered by 690VAC PWM VFDs require the use of an external filter to limit peak voltage spikes and the use of an INVERTER GRADE<sup>®</sup> motor. Where available, an alternative to using an output filter is to upgrade to a 2300V insulation system.

## Low Voltage TITAN<sup>®</sup> Motors

When using 449 frame and larger motors on PWM type VFDs consider the use of an external filter and shielded motor cables designed for PWM power to minimize harmonic distortion and peak voltages at the motor terminals. Harmonic distortion on the output waveform should be kept to a minimum level (less than 10%).

## Bearing Currents Related to PWM Waveforms

Due to the uniqueness of this condition occurring in the field, protection of the motor bearings from shaft currents caused by common mode voltages is not a standard feature on sine wave or Inverter Duty motor products, unless explicitly noted. Some installations may be prone to a voltage discharge condition through the motor bearings called Electrical Discharge Machining (EDM) or fluting.

EDM damage is related to characteristics of the PWM waveform, and the VFD programming, and installation factors.

Bearing EDM as a result of VFD waveform characteristics may be prevented by the installation of a shaft grounding device such as a brush or ring and/or correction of the installation characteristics causing the shaft voltage condition. Insulated bearing(s) may be required. VFD filters may be used if bearing fluting is to be mitigated.

## Bearing Protection on Inverter Duty Vertical Motors

All U.S. MOTORS<sup>®</sup> brand "Inverter Duty" vertical products have a shaft grounding system that allows damaging shaft currents a low resistance path to ground. **Bearings on vertical motors fed by VFD power without this bearing protection are not covered under any warranty.** All other bearing failure is covered per NMC's standard warranty. An electric motor repair shop approved to service U.S. MOTORS<sup>®</sup> brand motors must verify that the cause of the bearing failure was not due to EDM damage.

## Multiple Motors on a Single VFD

Special considerations are required when multiple motors are powered from a single VFD unit. Most VFD manufacturers can provide guidelines for proper motor thermal considerations and starting/stopping of motors. Cable runs from the VFD and each motor can create conditions that will cause extra stress on the motor winding. Filters may be required at the motor to provide maximum motor life.

## Grounding and Cable Installation Guidelines

Proper output winding and grounding practices can be instrumental in minimizing motor related failures caused by PWM waveform characteristics and installation factors. VFD manufacturers typically provide detailed guidelines on the proper grounding of the motor to the VFD and output cable routing. Cabling manufacturers provide recommended cable types for PWM installations and critical information concerning output wiring impedance and capacitance to ground.

## Vertical Motors on VFDs

Vertical motors operated on VFD power present unique conditions that may require consideration by the user or installation engineer:

- Locked rotor and drive tripping caused by non-reversing-ratchet operation at low motor speeds. It is not recommended to operate motors at less than 1/4 of synchronous speed. If slow speeds are required contact NMC engineering.
- Unexpected / unacceptable system vibration and or noise levels caused by the torque pulsation characteristics of the PWM waveform, a system critical frequency falling inside the variable speed range of the process or the added harmonic content of the PWM waveform exciting a system component
- Application related problems related to the controlled acceleration/ deceleration and torque of the motor on VFD power and the building of system pressure/ load.
- The impact the reduction of pump speed has on the down thrust reflected to the pump motor and any minimum thrust requirements of the motor bearings
- Water hammer during shutdown damaging the non-reversing ratchet

## Humidity and Non-operational Conditions

The possible build-up of condensation inside the motor due to storage in an uncontrolled environment or non-operational periods in an installation, can lead to an increased rate of premature winding or bearing failures when combined with the stresses associated with PWM waveform characteristics. Moisture and condensation in and on the motor winding over time can provide tracking paths to ground, lower the resistance of the motor winding to ground, and lower the Corona Inception Voltage (CIV) level of the winding.

Proper storage and maintenance guidelines are important to minimize the potential of premature failures. Space heaters or trickle voltage heating methods are the common methods for drying out a winding that has low resistance readings. **Damage caused by these factors are not covered by the limited warranty provided for the motor unless appropriate heating methods are properly utilized during non-operational periods and prior to motor start-up.**

**NEMA<sup>®†</sup> Application Guide for AC Adjustable Speed Drive Systems:** <http://www.nema.org/stds/acadjustable.cfm#download>

\* This information applies only to Integral Horsepower (IHP) motors as defined on the Agency Approval page, under UL<sup>®†</sup> & CSA<sup>®†</sup> listings where indicated.

† All marks shown within this document are properties of their respective owners.

# Warranty Guidelines for Integral Horsepower (IHP)\* Motors on Variable Frequency Drives

## Warranty Guidelines

The information in the following section refers to the motor and drive application guidelines and limitations for warranty.

## Hazardous Location Motors

Use of a variable frequency drive with the motors in this catalog, intended for use in hazardous locations, is only approved for Division 1, Class I, Group D hazardous location motors with a T2B temperature code, with a limitation of 2:1 constant torque or 10:1 variable torque output. No other stock hazardous location motors are inherently suitable for operation with a variable frequency drive. If other requirements are needed, including non-listed Division 2, please contact your Nidec Motor Corporation territory manager to conduct an engineering inquiry.

## 575 Volt Motors

575 volt motors can be applied on Inverters when output filters are used. Contact the drive manufacturer for filter selection and installation requirements.

## Applying INVERTER GRADE® Insulated Motors on Variable Frequency Drives (2, 4, 6 pole)

The products within this catalog labeled "Inverter Duty" or "Vector Duty" are considered INVERTER GRADE® insulated motors. INVERTER GRADE® motors exceed the NEMA®† MG-1 Part 31 standard. Nidec Motor Corporation provides a three-year limited warranty on all NEMA®† frame INVERTER GRADE® insulated motors and allows long cable runs between the motor and the VFD (limited to 400 feet without output filters). Cable distance can be further limited by hot and humid environments and VFD manufacturers cable limits. These motors may be appropriate for certain severe inverter applications or when the factors relating to the end use application are undefined (such as spares).

Nidec Motor Corporation's U.S. Motors® brand is available in the following INVERTER GRADE® insulated motors:

- Inverter Duty NEMA®† frame motors good for 10:1 Variable Torque & 5:1 Constant Torque, including Vertical Type RUSI
- Inverter Duty motors rated for 10:1 Constant Torque
- ACCU-Torq® and Vector Duty Motors with full torque to 0 Speed
- 841 Plus® NEMA®† Frame Motors

## Applying Premium Efficient motors (that do not have INVERTER GRADE® insulation) on Variable Frequency Drives (2, 4, 6 pole)

Premium efficient motors without INVERTER GRADE insulation meet minimum NEMA®† MG-1, Section IV, Part 31.4.4.2. These motors can be used with Variable Frequency Drives (with a reduced warranty period) under the following parameters:

- On NEMA®† frame motors, 10:1 speed rating on variable torque loads & 4:1 speed range on constant torque loads.
- On TITAN® frame motors, 10:1 speed rating on variable torque loads.
- On TITAN® frame motors, inquiry required for suitability on constant torque loads.

Cable distances are for reference only and can be further limited by hot and humid environments (refer to Table 1). Refer to specific VFD manufacturers cable limits. Refer to the Motor/ Inverter Compatibility page for special consideration of vertical motor bearings.

Table 1 - Cable Distances			
Maximum Cable Distance VFD to Motor			
Switching Frequency	460 Volt	230 Volt	380 Volt
3 Khz	127 ft	400 ft	218 ft
6 Khz	90 ft	307 ft	154 ft
9 Khz	73 ft	251 ft	126 ft
12 Khz	64 ft	217 ft	109 ft
15 Khz	57 ft	194 ft	98 ft
20 Khz	49 ft	168 ft	85 ft

## Warranty Period Clarifications and Exceptions

### Standard Energy Efficient Exclusion

Applying Standard & Energy Efficient Motors on Variable Frequency Drives is not recommended. VFD related failures on standard and energy efficient motors will not be covered under warranty.

### Vertical Motor Windings

Premium efficient vertical motors without INVERTER GRADE® insulation that are installed using the criteria described in this document and applied in the correct applications shall have a warranty while powered by a VFD for 12 months from date of installation or 18 months from date of manufacturing whichever comes first. See limited warranty page for horizontal motor warranty periods.

### Bearing Exclusion for Thrust Handling Bearings

Bearings used in premium efficient vertical motors, and all thrust handling bearings, that are powered by VFDs without shaft grounding devices or insulated bearings (when required) will not be covered under any warranty for damages caused from being powered by a VFD. All other bearing failure is covered per NMC's standard warranty. An electric motor repair shop approved to service U.S. MOTORS® brand motors must verify that the cause of the bearing failure was not due to Electrical Discharge Machining.

### Medium Voltage and Slow Speed Considerations

Motors that are rated above 700 VAC or that are eight pole and slower require special consideration and installation and are not covered under the warranty guidelines in this document. Motors that are rated above 700VAC have special cable length and voltage differential issues that are specific to the VFD type and manufacture. The motor construction and cost may vary dramatically depending on the VFD topology and construction. Contact your NMC representative with VFD manufacturer name and model type for application and motor construction considerations. Motors that are designed eight pole and slower also require special installation and filters per the drive manufacturer.

\* This information applies only to Integral Horsepower (IHP) motors as defined on the Agency Approval page, under UL®† & CSA®† listings where indicated.

† All marks shown within this document are properties of their respective owners.



## Limited Warranty

Refer to [usmotors.com](http://usmotors.com) website for the most up-to-date warranty information.

All Nidec Motor Corporation products shall carry the limited warranty of 12 months from the date of installation, not to exceed 18 months from date of manufacture as specified in Section 5 of the Nidec Motor Corporation's Terms and Conditions of Sale except those specifically listed below, or noted within individual product family pages within this catalog.

	Installed / Manufactured	Installed / Manufactured
<b>Industrial Motors 140 - 447 Frames</b>	<b>Sine Wave Power</b>	<b>VFD Power</b>
Premium Efficient & NEMA® Premium	36 / 42 months	12 / 18 months **
Inverter Duty	36 / 42 months	36 / 42 months
<b>TITAN Motors - 449 Frame and Larger</b>	<b>Sine Wave Power</b>	<b>VFD Power</b>
Premium Efficient	24 / 30 months	12 / 18 months **
Inverter Duty	24 / 30 months	24 / 30 months

\*\* Must have Shaft Grounding System for bearings to be covered. See Warranty Guidelines for IHP Motors on VFDs for bearing exclusions on vertical motors.

## Deferred & Extended Warranty Information

### DEFERRED AND EXTENDED WARRANTIES (OPTIONAL WARRANTIES)

Deferred and extended warranties, defined as follows, apply only to 449 frame and larger horizontal and vertical motors, for use in the continental United States only. All optional warranties must be approved in writing by Nidec Motor Corporation. Contact Marketing for Approval.

#### Deferred Warranty

Nidec Motor Corporation's limited warranty, as set forth in the standard terms and conditions of sale, page vi, shall apply subject to the following modification: for a 5% addition to the net price of the motor ("Net Adder"), the warranty period on the motor will be for a period of one year (or more for applicable products) from that date of initial operation, but not in excess of 60 months from the date of shipment subject to the following conditions:

- That within thirty days prior to initial operation, a Nidec Motor Corporation (NMC) Service Engineer, or authorized NMC Service Station, be hired by the Buyer at Buyer's expense, to thoroughly inspect the motor to ascertain that the motor is in "as shipped" condition. This inspection will include but not be limited to:
  - Megger test of winding insulation.
  - Internal inspection to determine that the winding has not been damaged and that the motor is clean and dry.
  - Inspection of the bearings to determine they have not been damaged and there is no water in the oil reservoirs.
  - External inspection to determine that no damage has been made.
- Make any corrections which this inspection shows to be needed because the motor has been in storage or standing idle. These corrections will be made at Buyer's expense if corrections required are due to causes other than defects in material or workmanship.
- That an affidavit certifying that the motor has successfully passed the inspection and is in "as shipped" condition be supplied to NMC by Buyer. Failure to provide NMC with the affidavit certifying that the motor has passed inspection and is in "as shipped" condition will result in voiding the warranty.

#### Extended Warranty

When Buyer's specification requires a warranty period longer than the limited warranty set forth in Nidec Motor Corporation's standard terms and conditions of sale, page vi, the net price of each motor will be increased according to the schedule, which follows. Nidec Motor Corporation may accept an order with up to 60 months coverage.

From Mfg. Date	From Install	Net Adder
30 months	24 months	2%
42 months	36 months	3%
54 months	48 months	5%
66 months	60 months	6%





# Nidec Motor Corporation

## Division of Nidec Motor Corporation — Terms & Conditions of Sale

Nidec Motor Corporation, referred to herein as the "Seller" and the customer or person or entity purchasing goods ("Goods") from Seller is referred to as the "Buyer." These Terms and Conditions, any price list or schedule, quotation, acknowledgment or invoice from Seller relevant to the sale of the Goods and all documents incorporated by specific reference herein or therein, constitute the complete and exclusive statement of the terms of the agreement governing the sale of Goods by Seller to Buyer. Seller's acceptance of Buyer's purchase order is expressly conditional on Buyer's assent to all of Seller's terms and conditions of sale, including terms and conditions that are different from or additional to the terms and conditions of Buyer's purchase order. Buyer's acceptance of or payment for the Goods will manifest Buyer's assent to these Terms and Conditions. Seller reserves the right in its sole discretion to refuse orders.

1. **PRICES:** Prices for Goods, whether specified in Seller's price list or schedule, acknowledgment or written quotation, are subject to change without notice. Such prices shall be adjusted to reflect Seller's prices for Goods as in effect at the time of requested shipment date, and each shipment will be invoiced at such prices. All prices are exclusive of taxes, transportation and insurance, which are to be borne by Buyer.

2. **TAXES:** Any current or future tax or governmental charge (or increase in same) affecting Seller's costs of production, sale, or delivery or shipment, or which Seller is otherwise required to pay or collect in connection with the sale, purchase, delivery, storage, processing, use or consumption of Goods, shall be for Buyer's account and shall be added to the price or billed to Buyer separately, at Seller's election.

3. **TERMS OF PAYMENT:** Unless otherwise specified by Seller, terms are net thirty (30) days from date of Seller's invoice in U.S. currency. Seller shall have the right, among other remedies, either to terminate this agreement or to suspend further performance under this and/or other agreements with Buyer in the event Buyer fails to make any payment when due, which other agreements Buyer and Seller hereby amend accordingly. Buyer shall be liable for all expenses, including attorneys' fees, relating to the collection of past due amounts. If any payment owed to Seller is not paid when due, it shall bear interest, at a rate to be determined by Seller, which shall not exceed the maximum rate permitted by law, from the date on which it is due until it is paid. Should Buyer's financial responsibility become unsatisfactory to Seller, cash payments or security satisfactory to Seller may be required by Seller for future deliveries and for the Goods therefore delivered. If such cash payment or security is not provided, in addition to Seller's other rights and remedies, Seller may discontinue deliveries. Buyer hereby grants Seller a security interest in all Goods sold to Buyer by Seller, which security interest shall continue until all such Goods are fully paid for in cash, and Buyer, upon Seller's demand, will execute and deliver to Seller such instruments as Seller requests to protect and perfect such security interest.

4. **SHIPMENT AND DELIVERY:** While Seller will use all reasonable commercial efforts to maintain the delivery date(s) acknowledged or quoted by Seller, all shipping dates are approximate and not guaranteed. Seller reserves the right to make partial shipments. Seller, at its option, shall not be bound to tender delivery of any Goods for which Buyer has not provided shipping instructions and other required information. If the shipment of the Goods is postponed or delayed by Buyer for any reason, Buyer agrees to reimburse Seller for any and all storage costs and other additional expenses resulting therefrom. Each shipment is F.C.A. Seller's shipping point (Incoterms 2010). In accordance with the foregoing Incoterm, risk of loss for damage and responsibility for the Goods shall pass from Seller to Buyer for each shipment upon delivery to and receipt by carrier at Seller's shipping point and legal title to the shipped Goods shall transfer to Buyer for each shipment as and when risk of loss with respect to such shipment transfers to Buyer. Any claims for shortages or damages suffered in transit are the responsibility of Buyer and shall be submitted by Buyer directly to the carrier. Shortages or damages must be identified and signed for at the time of delivery.

5. **LIMITED WARRANTY:** Subject to the limitations of Section 6, Seller warrants that the Goods manufactured by Seller, other than those specifically identified below, will be free from defects in material and workmanship and meet Seller's published specifications at the time of shipment under normal use and regular service and maintenance for a period of twelve (12) months from the date of shipment of the Goods by Seller or eighteen (18) months from the date of manufacture, whichever occurs sooner, unless otherwise specified by Seller in writing. Partial Motors of any kind not fully assembled by Seller shall carry no warranty of any kind, express or implied. Products purchased by Seller from a third party for resale to Buyer ("Resale Products") shall carry only the warranty extended by the original manufacturer. **THE WARRANTY SET FORTH IN THIS SECTION 5 AND THE WARRANTY SET FORTH IN SECTION 7, ARE THE SOLE AND EXCLUSIVE WARRANTIES GIVEN BY SELLER WITH RESPECT TO THE GOODS AND ARE IN LIEU OF AND EXCLUDE ALL OTHER WARRANTIES, EXPRESS OR IMPLIED, ARISING BY OPERATION OF LAW OR OTHERWISE, INCLUDING WITHOUT LIMITATION, MERCHANTABILITY AND FITNESS FOR A PARTICULAR PURPOSE WHETHER OR NOT THE PURPOSE OR USE HAS BEEN DISCLOSED TO SELLER IN SPECIFICATIONS, DRAWINGS OR OTHERWISE, AND WHETHER OR NOT SELLER'S PRODUCTS ARE SPECIFICALLY DESIGNED AND/OR MANUFACTURED BY SELLER FOR BUYER'S USE OR PURPOSE.**

This warranty does not extend to any losses or damages due to misuse, accident, abuse, neglect, normal wear and tear, negligence (other than Seller's), unauthorized modification or alteration, use beyond rated capacity, unsuitable power sources or environmental conditions, improper installation, repair, handling, maintenance or application or any other cause not the fault of Seller. To the extent that Buyer or its agents has supplied specifications, information, representation of operating conditions or other data to Seller in the selection or design of the Goods and the preparation of Seller's quotation, and in the event that actual operating conditions or other conditions differ from those represented by Buyer, any warranties or other provisions contained herein which are affected by such conditions shall be null and void.

If within thirty (30) days after Buyer's discovery of any warranty defects within the warranty period, Buyer notifies Seller thereof in writing, Seller shall, at its option and as Buyer's exclusive remedy, repair, correct or replace or refund the purchase price for that portion of the Goods found by Seller to be defective. Failure by Buyer to give such written notice within the applicable time period shall be deemed an absolute and unconditional waiver of Buyer's claim for such defects. Seller shall have the right to require the Buyer to deliver the Goods to Seller's designated repair center or manufacturing facility. All costs associated with dismantling, reinstallation and transportation to and from Seller's designated repair center or manufacturing facility and the time and expense of Seller's personnel and representatives for site travel and diagnosis under this warranty shall be borne by the Buyer. Goods repaired or replaced during the warranty period shall be covered by the foregoing warranty for the remainder of the original warranty period or ninety (90) days from the date of shipment, whichever is longer. Buyer assumes all other responsibility for any loss, damage, or injury to persons or property arising out of, connected with, or resulting from the use of Goods, either alone or in combination with other products/components.

Section 5 applies to any entity or person who may buy, acquire or use the Goods, including any entity or person who obtains the Goods from Buyer, and shall be bound by the limitations herein, including Section 6. Buyer agrees to provide such subsequent transferees conspicuous, written notice of the provisions of Sections 5 and 6.

6. **LIMITATION OF REMEDY AND LIABILITY; THE SOLE AND EXCLUSIVE REMEDY FOR BREACH OF ANY WARRANTY HEREUNDER (OTHER THAN THE WARRANTY PROVIDED UNDER SECTION 7) SHALL BE LIMITED TO REPAIR, CORRECTION OR REPLACEMENT, OR REFUND OF THE PURCHASE PRICE UNDER SECTION 5.**

**SELLER SHALL NOT BE LIABLE FOR DAMAGES CAUSED BY DELAY IN PERFORMANCE AND THE REMEDIES OF BUYER SET FORTH IN THIS AGREEMENT ARE EXCLUSIVE. IN NO EVENT, REGARDLESS OF THE FORM OF THE CLAIM OR CAUSE OF ACTION, WHETHER BASED IN CONTRACT, INFRINGEMENT, NEGLIGENCE, STRICT LIABILITY, OTHER TORT OR OTHERWISE, SHALL SELLER'S LIABILITY TO BUYER AND/OR ITS CUSTOMERS EXCEED THE PRICE PAID BY BUYER FOR THE SPECIFIC GOODS PROVIDED BY SELLER GIVING RISE TO THE CLAIM OR CAUSE OF ACTION. BUYER AGREES THAT IN NO EVENT SHALL SELLER'S LIABILITY TO BUYER AND/OR ITS CUSTOMERS EXCEED TO INCLUDE INCIDENTAL, CONSEQUENTIAL OR PUNITIVE DAMAGES.** The term "consequential damages" shall include, but not be limited to, loss of anticipated profits, business interruption, loss of use, revenue, reputation and data, costs incurred, including without limitation, for capital, fuel, power and loss or damage to property or equipment.

It is expressly understood that any technical advice furnished by Seller with respect to the use of the Goods is given without charge, and Seller assumes no obligation or liability for the advice given, or results obtained, all such advice being given and accepted at Buyer's risk.

7. **PATENTS AND COPYRIGHTS:** Subject to the limitations of the second paragraph of Section 6, Seller warrants that the Goods sold, except as are made specifically for Buyer according to Buyer's specifications, do not infringe any valid U.S. patent or copyright in existence as of the date of shipment. This warranty is given upon the condition that Buyer promptly notifies Seller of any claim or suit involving Buyer in which such infringement is alleged and cooperates fully with Seller and permit Seller to control completely the defense, settlement or compromise of any such allegation of infringement. Seller's warranty as to use patents only applies to infringement arising solely out of the inherent operation according to Seller's specifications and instructions (i) of such Goods, or (ii) of any combination of Goods acquired from Seller in a system designed by Seller. In the event such Goods are held to infringe such a U.S. patent or copyright in such suit, and the use of such Goods is enjoined, or in the case of a compromise or settlement by Seller, Seller shall have the right, at its option and expense, to procure for Buyer the right to continue using such Goods, or replace them with non-infringing Goods, or modify same to become non-infringing, or grant Buyer a credit for the depreciated value of such Goods and accept return of them. In the event of the foregoing, Seller may also, at its option, cancel the agreement as to future deliveries of such Goods, without liability. No license or rights in any of Seller's intellectual property associated with the Goods is granted hereby.

In the event that the Goods provided by Seller, as well as any services provided by Seller ("Services"), regardless of whether the Services are at the request or on behalf of Buyer, are part of a project ("Project"), or are performed alone or are related to the provision of Goods, contain or incorporate any work product, including but not limited to concepts, inventions (patentable or

otherwise), works, drawings, designs, information, specifications, customizations, optimizations, improvements, documentation, and programs or software, in each case regardless of whether developed by Seller alone or with others, whether completed or work-in-progress, or whether completed at Buyer's request, Buyer's cost, or as part of a Project performed for Buyer (any and all of the foregoing being "Work Product"), Seller owns all right, title, and interest (including, but not limited to, any patents, copyrights, or other intellectual property rights) in such final Work Product, including any and all intermediate Work Product developed as part or in pursuit of the final Work Product, in connection with, embodied in, or encompassed by any Good, Service, or Project deliverable. Seller makes no transfer or license to Buyer of any right, title, or interest in or to the Work Product or in or to any of Seller's intellectual property or proprietary rights.

8. **EXCUSE OF PERFORMANCE:** Seller shall not be liable for delays in performance or for non-performance due to acts of God; acts of Buyer; war; fire; flood; weather; sabotage; strikes or labor disputes; civil disturbances or riots; governmental restraints, restrictions, allocations, laws, regulations, orders or actions; unavailability of or delays in transportation; default of suppliers; or unforeseen circumstances or any events or causes beyond Seller's reasonable control. Deliveries or other performance may be suspended for an appropriate period of time or canceled by Seller upon notice to Buyer in the event of any of the foregoing, but the balance of the agreement shall otherwise remain unaffected as a result of the foregoing.

If Seller determines that its ability to supply the total demand for the Goods, or to obtain material used directly or indirectly in the manufacture of the Goods, is hindered, limited or made impracticable due to causes set forth in the preceding paragraph, Seller may allocate its available supply of the Goods or such material (without obligation to acquire other supplies of any such Goods or material) among itself and its purchasers on such basis as Seller determines to be equitable without liability for any failure of performance which may result therefrom.

9. **CANCELLATION:** Buyer may cancel orders only upon reasonable advance written notice and upon payment to Seller of Seller's cancellation charges which include, among other things, all costs and expenses incurred, and, to cover commitments made, by the Seller and a reasonable profit thereon. Seller's determination of such termination charges shall be conclusive.

10. **CHANGES:** Buyer may request changes or additions to the Goods consistent with Seller's specifications and criteria. In the event such changes or additions are accepted by Seller, Seller may revise the price and dates of delivery. Seller reserves the right to change designs and specifications for the Goods without prior notice to Buyer, except with respect to Goods being made to order for Buyer. Seller shall have no obligation to install or make such change in any Goods manufactured prior to the date of such change.

11. **NUCLEAR/MEDICAL. UNLESS OTHERWISE AGREED IN WRITING BY SELLER: (i) GOODS SOLD HEREUNDER ARE NOT FOR USE IN CONNECTION WITH ANY NUCLEAR, MEDICAL, LIFE-SUPPORT AND RELATED APPLICATIONS. (ii) BUYER ACCEPTS GOODS WITH THE FOREGOING UNDERSTANDING, AGREES TO COMMUNICATE THE SAME IN WRITING TO ANY SUBSEQUENT PURCHASERS OR USERS AND (iii) BUYER AGREES TO DEFEND, INDEMNIFY AND HOLD HARMLESS SELLER FROM ANY CLAIMS, LOSSES, SUITS, JUDGMENTS AND DAMAGES, INCLUDING INCIDENTAL AND CONSEQUENTIAL DAMAGES, ARISING FROM SUCH USE, WHETHER THE CAUSE OF ACTION BE BASED IN TORT, CONTRACT OR OTHERWISE, INCLUDING ALLEGATIONS THAT THE SELLER'S LIABILITY IS BASED ON NEGLIGENCE OR STRICT LIABILITY.**

12. **ASSIGNMENT:** Buyer shall not assign its rights or delegate its duties hereunder or any interest herein without the prior written consent of Seller, and any such assignment, without such consent, shall be void.

13. **QUANTITY:** Buyer agrees to accept overruns of up to ten percent (10%) of the order on "made-to-order" goods, including parts. Any such additional items shall be priced at the price per item charged for the specific quantity ordered.

14. **REPLACEMENT / SERVICE GOODS:** Upon the cancellation or fulfillment of this order, Seller will have no obligation to sell and Buyer will have no obligation to purchase the Goods sold hereunder, including, but not limited to, the supply of replacement parts for Goods or Goods for Buyer's consumer service division. Seller is not obligated to sell Buyer or its consumer service divisions Goods: (i) for any fixed period of time after production of the Goods supplied hereunder ceases or after the last date of shipment made under this order; or (ii) at any pre-established price to fulfill Buyer's or its consumer service divisions requirements during or after production of the Goods ceases or after the last date of shipment under this order. Seller shall have the absolute right to revise the price of Goods and the terms of sale and to modify or discontinue the sale of the Goods, and such action shall not form the basis of any claim by Buyer against Seller.

15. **TOOLING:** Tool, die, and pattern charges, if any, are in addition to the price of the Goods and are due and payable upon completion of the tooling. All such tools, dies and patterns shall be and remain the property of Seller. Charges for tools, dies, and patterns do not convey to Buyer, title, ownership interest in, or rights to possession or removal, or prevent their use by Seller for other purchasers, except as otherwise expressly provided by Seller and Buyer in writing with reference to this provision.

16. **INSPECTION/TESTING:** Buyer, at its option and expense, may inspect and observe the testing by Seller of the Goods for compliance with Seller's standard test procedures prior to shipment, which inspection and testing shall be conducted at Seller's plant at such reasonable time as is specified by Seller. Any rejection of the Goods must be made promptly by Buyer before shipment. Tests shall be deemed to be satisfactorily completed and the test fully met when the Goods meet Seller's criteria for such procedures.

17. **DRAWINGS:** Seller's prints and drawings (including without limitation, the underlying technology) furnished by Seller to Buyer in connection with this agreement are the property of Seller and Seller retains all rights, including without limitation, exclusive rights of use, licensing and sale. Possession of such prints or drawings does not convey to Buyer any rights or license, and Buyer shall return all copies (in whatever medium) of such prints or drawings to Seller immediately upon request therefor.

18. **EXPORT/IMPORT:** Buyer agrees that all applicable import and export control laws, regulations, orders and requirements, including without limitation those of the United States and the European Union, and the jurisdictions in which the Seller and Buyer are established or from which Goods may be supplied, will apply to their receipt and use. In no event shall Buyer use, transfer, release, import, export, Goods in violation of such applicable laws, regulations, orders or requirements.

19. **INSURANCE:** Seller shall carry adequate product liability and commercial general liability insurance. Seller shall, upon written request from Buyer, furnish Buyer with certificates of insurance confirming the existence of such insurance. Seller does not waive its, or its insurers', rights of subrogation.

20. **GENERAL PROVISIONS:** These terms and conditions supersede all other communications, negotiations and prior oral or written statements regarding the subject matter of these terms and conditions. No change, modification, rescission, discharge, abandonment, or waiver of these terms and conditions shall be binding upon the Seller unless made in writing and signed on its behalf by a duly authorized representative of Seller. No conditions, usage of trade, course of dealing or performance, understanding or agreement purporting to modify, vary, explain, or supplement these terms and conditions shall be binding unless hereafter made in writing and signed by the party to be bound, and no modification or additional terms shall be applicable to this agreement by Seller's receipt, acknowledgment, or acceptance of purchase orders, shipping instruction forms, or other documentation containing terms at variance with or in addition to those set forth herein. Any such modifications or additional terms are specifically rejected and deemed a material alteration hereof. If this document shall be deemed an acceptance of a prior offer by Buyer, such acceptance is expressly conditional upon Buyer's assent to any additional or different terms set forth herein. No waiver by either party with respect to any breach or default or of any right or remedy, and no course of dealing, shall be deemed to constitute a continuing waiver of any other breach or default or of any other right or remedy, unless such waiver be expressed in writing and signed by the party to be bound. All typographical or clerical errors made by Seller in any quotation, acknowledgment or publication are subject to correction.

The validity, performance, and all other matters relating to the interpretation and effect of this agreement shall be governed by the law of the state of Missouri without regard to its conflict of laws principles. Buyer and Seller agree that the proper venue for all actions arising in connection herewith shall be only in Missouri and the parties agree to submit to such jurisdiction. No action, regardless of form, arising out of transactions relating to this contract, may be brought by either party more than two (2) years after the cause of action has accrued. The U.N. Convention on Contracts for the International Sales of Goods shall not apply to this agreement.



# Catalog Numbering System (IHP)

<b>C</b> CORRO-DUTY®	<b>25</b> HP	<b>E</b> Energy Efficient Three Phase	<b>( )</b>	<b>2</b> 4 Pole	<b>B</b> 230/460 Volts	<b>( )</b>	<b>( )</b>	<b>C</b> C-Face	<b>R</b> No Base (Footless)	<b>( )</b>
<b>1</b>	<b>2</b>	<b>3</b>	<b>4</b>	<b>5</b>	<b>6</b>	<b>7</b>	<b>8</b>	<b>9</b>	<b>10</b>	<b>11</b>

## 1 PRODUCT FAMILY

8P	841 PLUS®
A	AUTOMOTIVE DUTY
AB	AUTO DUTY BRKLESS BRKMTR
B	INVERTER DUTY BLOWER COOLED
BD	BELT DRIVE FAN
BF	BRAKE MOTOR-FAST
BM	BRAKE MOTOR
BMU	UNIMOUNT® BRAKE MOTOR
BR	BRAKE MOTOR-FCR
C	CORRO-DUTY®
CA	CORRO-DUTY® ARCTIC DUTY
CJ	CORRO-DUTY® CCP
CO	CONDENSER FAN
D	ODP GEN. PURPOSE
DC	ODP COMPRESSOR
DD	DIRECT DRIVE FAN
DH	DRY HYDRO
DJ	ODP CCP MOTOR
E	ELEVATOR MOTOR - L32 FLANGE
EE	COMMERCIAL PUMP/GEN. PURPOSE
ELT	E-LINE®
EZ	ELEVATOR MOTOR - Z-FLANGE
FD	FARM DUTY
FDU	FARM DUTY - ULTRA HIGH TORQUE
FF	FIREPUMP
FP	FLOOR POLISHER - 1 PHASE
H	HOSTILE DUTY
HA	HOSTILE DUTY CAST IRON CONDUIT BOX
HC	HOSTILE DUTY - ALL CAST IRON
HJ	HOSTILE DUTY CCP
HO	HIGH THRUST OPEN
HS	HIGH THRUST OPEN - 1 PHASE
HT	HIGH THRUST TEFC
HW	COOLING TOWER TEAO
HW	COOLING TOWER TEFC
J	CCP
JD	JET PUMP OPEN MOTOR
JT	JET PUMP TEFC MOTOR
KT	FINISHED GOODS KITS
LD	L.S. BUYOUT ODP
LT	L.S. BUYOUT TEFC
M	IEC METRIC (reference IEC Family)
NO	NORMAL THRUST OPEN
NT	NORMAL THRUST TEFC
PD	PEDESTAL FAN
PF	POWER FACTOR CORR CAPS
PT	POWER TOOL
PW	PRESSURE WASHER
S	UNIMOUNT® ROLLED STEEL
T	TEFC
TA	TEAO
TN	TENV
U	UNIMOUNT®
UJ	UT CCP
UN	UT TENV
UV	UT TEAO
VN	VECTOR NON-VENT
WD	WASHDOWN DUTY
WDP	WASHDOWN DUTY PAINT FREE
WDS	WASHDOWN DUTY ALL STAINLESS
WI	WEATHER PROTECTED TYPE I
WII	WEATHER PROTECTED TYPE II
X	HAZ. LOCATION DUAL LABEL
XA	HAZ. LOCATION AUTOMOTIVE DUTY
XC	HAZ. LOCATION DUAL LABEL CORRO-DUTY®
XJ	HAZ. LOCATION DUAL LABEL CCP
XS	HAZ. LOCATION DUAL STEEL FRAME
Y	HAZ. LOCATION SINGLE LABEL
YC	HAZ. LOCATION SINGLE LABEL CORRO-DUTY®
YS	HAZ. LOCATION SINGLE LABEL CCP

HD	HOSTILE DUTY (WORLD MOTOR)
HDA	HOSTILE DUTY (WORLD MOTOR) CAST IRON C/BOX
CD	CORRO-DUTY (WORLD MOTOR)
8D	841 PLUS® (WORLD MOTOR)
MHD	IEC HOSTILE DUTY (WORLD MOTOR)
M8D	IEC 841 PLUS (WORLD MOTOR)

## 2 HP (NEMA)      2 KW (IEC)

0	SPECIAL	0	SPECIAL
110	1/10	0012	.12
112	1/12	0018	.18
18	1/8	0025	.25
16	1/6	0037	.37
14	1/4	004	.40
13	1/3	0055	.55
12	1/2	0075	.75
34	3/4	011	1.1
1	1	015	1.5
32	1-1/2	018	1.8
2	2	022	2.2
3	3	03	3
5	5	037	3.7
7	7-1/2	04	4
10	10	055	5.5
15	15	075	7.5
20	20	11	11
25	25	15	15
30	30	18	18.5
40	40	22	22
50	50	30	30
60	60	37	37
75	75	45	45
100	100	55	55
125	125	75	75
150	150	90	90
200	200	110	110
etc		132	132
		160	160
		200	200
		etc	

\*USE KW WHEN IEC FAMILY SELECTED

## 3 ELECTRICAL

A	PERM SPLIT CAP (1Ø)
B	SPLIT PHASE (1Ø)
C	CAP START (1Ø)
D	CONSTANT TORQ 2WDG (3Ø)
E	ENERGY EFFICIENT (IE2) (3Ø)
F	CONSTANT HP 1WDG (3Ø)
G	CONSTANT HP 2WDG (3Ø)
K	VAR TORQ 2WDG (3Ø)
L	VAR TORQ 1WDG (3Ø)
P	PREMIUM EFFICIENT (IE3) (3Ø)
Q	DESIGN C (3Ø)
R	CONSTANT TORQ 1WDG (3Ø)
S	STD EFFICIENT (IE1) (3Ø)
T	INV DUTY CON TORQ (3Ø)
V	INV DUTY VAR TORQ (3Ø)

DEFAULT MULTISPEED IS STD EFF P&E PRECEDING MULTI-SPD ARE  
P PREM EFF  
E ENERGY EFF

## 4 SECOND ELECTRICAL

A	AUTO PROTECT
M	MANUAL PROTECT
R	INSTANT REVERSING GATE DOOR
T	TWO COMPARTMENT
Y	TITAN® F RISE @ 1.0 SF

## 5 POLES

1	2P
2	4P
3	6P
4	8P
5	10P
6	12P
7	14P
8	16P
9	4/8P
10	4/6P
12	2/4P
26	4/12P
34	6/8P
36	6/12P

## 6 VOLTAGES

2	2300
A	208-230/460 OR 200-230/460
B	230/460
C	460
D	208-230/460 & 190/380
E	230/460 & 190/380 OR 230/460 & 200/400
F	460/380 OR 460/400
G	575
H	200 OR 200-208
I	90
J	115/208-230
K	230 & 208-230
L	110/220
M	220/440 & 208-220/440
N	115
P	115/230
Q	180 (DC) & 190/380 (DC)
R	220/380-440 (Y-DELTA)
S	460 PWS
T	400 (50HZ)
U	380/660 & 400/690 (50HZ)
V	4000
W	2300/4000
X	200/400
Y	230/400 (50HZ)
Z	OTHER

## 7 FRAME

DEFAULT 56 FRAME (FRACTIONAL 3Ø & ALL 1Ø) NEMA FRAME ASSIGNMENT (INTEGRAL HP)  
FRACTIONAL 3Ø & ALL 1Ø  
4 = 48  
42 = 142  
14 = 140  
18 = 180  
21 = 210  
H = SPECIAL NEMA 56H

INTEGRAL HP 3Ø  
F = DOWN FRAME  
G = UPFRAME  
AIR CIRCULATORS/FANS  
20 = 20" CIRC. HEAD DIA.  
24 = 24" CIRC. HEAD DIA.  
30 = 30" CIRC. HEAD DIA.

## 8 SHAFT

NEMA	T SHAFT; STD 48 OR 56
DEFAULT	VSS (VERTICAL)
S	SHORT SHAFT
L	VHS
M	JM
P	JP
J	WEST COAST CCP
T	TM SHAFT
U	JMV
V	JPV
Z	SPECIAL

## 9 FLANGE (2ND DIGIT)

DEFAULT	NONE (HORZ)
P-BASE	(VERT)
A	SLEEVE BEARING
B	ROLLER BEARING
C	C-FACE
D	D-FLANGE
K	TCH (SPECIAL 'AK')
Q	SQUARE FLANGE
Y	SPECIAL

## 10 BASE (3RD DIGIT)

DEFAULT NEMA	F-1 RIGID BASE
DEFAULT IEC	F-3 RIGID BASE
R	NO BASE (FOOTLESS)
1	F-1 ASSEMBLY
2	F-2 ASSEMBLY
3	F-0 ASSEMBLY
5	W-5 ASSEMBLY
6	W-6 ASSEMBLY
7	YOKE MOUNT
8	W-8 ASSEMBLY
9	RESILIENT BASE
E	P-BASE 10" BD
F	P-BASE 12" BD
G	P-BASE 16.5" BD
H	P-BASE 20" BD
J	P-BASE 24.5" BD

## 11 SPECIAL FEATURES (4TH DIGIT)

N	NO NRR (SRC) (VERT)
S	SPECIAL MOUNTING
T	TUNGSTEN SEAL (VERT)
X	EXTRA HIGH THRUST (VERT)
-C	CONVERSION
-P	PRODUCTION

† All marks shown within this document are properties of their respective owners.



# Typical Motor Construction Features

## Vertical Motors with Anti-Friction Bearings

### NEMA®† Single Phase (213 thru 254 Frame)

Enclosure	Efficiency Level	Inverter Duty	Stator Frame Material	Holloshaft® High-Thrust
WPI	Standard	No	Aluminum	AUC (Cap Start/Induction Run)
				AUR (Cap Start/Cap Run)

### NEMA Three Phase (182 thru 447 Frame)

Enclosure	Efficiency Level	Inverter Duty	Stator Frame Material	Shaft/Thrust Configuration	
				HOLLOSHAFT®	Solid Shaft
				High-Thrust	Normal-Thrust
WPI	Premium	Yes	Aluminum	AUSI	*
	Premium	No		AUS	AVS
	Premium	Yes	Cast Iron	RUSI	*
	Premium	No		RUS	RVS
TEFC	Premium	Yes	Cast Iron or Aluminum	TUI	*
	Premium	No		TUS	TVS

### TITAN® Three Phase (449 and 5008 Frame)

Enclosure	Efficiency Level	Inverter Duty	Stator Frame Material	HOLLOSHAFT® High-Thrust
WPI	Premium	Yes	Cast Iron	RUSI, RUEI
	Premium	No		RUS, RUE
TEFC	Premium	Yes	Cast Iron	JUEI
	Premium	No		JUE

† All marks shown within this document are properties of their respective owners.



## Typical Motor Construction Features

### FRAME MATERIAL:

#### NEMA<sup>†</sup> FRAMES (180 thru 447)

Type: AVS, AUS, AUSI	Aluminum
RVS, RUS, RUSI,	Cast Iron
TVS, TUS	Aluminum (180-280 Frames)
TVS, TUS, TUI	Cast Iron (320-440 Frames)
TUCI, TCEF, TVCS	Cast Iron

#### TITAN<sup>®</sup> FRAMES (449 & 5008)

Type: RUS, RUSI, RUE, RUEI	Cast Iron
JUE, JUCEI	Cast Iron

### BRACKETS:

#### NEMA<sup>†</sup> FRAMES

Both end brackets are cast iron except for the following:  
 Type AV: Upper bracket on 180 & 210 frames is aluminum.  
 Type TV: Upper bracket on 180-280 frames is aluminum.  
 Type TU: Upper bracket on 250 & 280 frames is aluminum.

#### TITAN<sup>®</sup> FRAMES (449 & 5008)

Type: RUS, RUSI, RUE, RUEI	Cast Iron
JUEI, JUCEI	Cast Iron

**CANOPY CAP:** Constructed of plastic, steel, aluminum, fiberglass or cast iron depending on exact frame and type.

**FAN COVER (TEFC):** Constructed of plastic, steel, aluminum or cast iron depending on exact frame and type.

**BEARING CAPS:** All Vertical motors are furnished with lower bearing caps constructed of aluminum or cast iron.

## BEARING LUBRICATION

Frame	Type	Upper Bearing	Lower Bearing	Thrust Capacity
180-280	AUC, AUR, AUS, AUSI	Grease	Grease**	High
180-440	AVS, TVS, TCEF, TVCS	Grease	Grease	Normal
320-447	RVS	Grease	Grease	Normal
	RUS, RUSI	Oil	Grease	High
449	RUS, RUSI, JUE, JUCEI	Oil	Grease	High
180-360	TUS, TUCI	Grease	Grease**	High
400-440		Oil	Grease	High
5000	RUE, RUEI	Oil	Grease	High

\*\*Lower bearing is thrust bearing.



# Vertical HOLLOSHAFT® High Thrust Motors - "P" Base, Single Phase Weather Protected Type I (WPI) Standard Efficient

## APPLICATIONS:

For use on Turbine, Mix Flow and Propeller Pumps

## FEATURES:

- Class F Insulation
- 1.15 Service Factor
- Maximum 40°C Ambient, 3,300 Feet Altitude
- Capacitor Start Design
- Corrosion Resistant Mill & Chemical Duty Paint
- NRR = Non-Reverse Ratchet
- Discount Symbol: DS-7VS

HP	RPM	Volts	Frame	Catalog Number	Type	List w/NRR	List w/SRC	Down Thrust (lbs.)	Base Dia (in.)	Cplg Height (in.)	Cplg BX (in.)	Cplg Key Size	Ship Wt. (lbs.)	Notes
3	1800	115/230	215P	HS3C2PLE	AUR	\$4,568	\$4,291	2500	10	17-9/16	1	1/4	220	
5	3600	230	215P	HS5C1KLE	AUR	\$4,779	\$4,502	2200	10	17-9/16	1	1/4	220	
	1800	230	254UP	HS5C2KLE	AUC	\$5,789	\$5,460	2500	10	23-3/8	1	1/4	265	
7 1/2	3600	230	254UP	HS7C1KLE	AUC	\$6,817	\$6,488	2600	10	23-3/8	1	1/4	265	
	1800	230	256UP	HS7C2KLE	AUC	\$7,831	\$7,455	3300	10	23-3/8	1	1/4	300	

NOTE: Alternative Coupling Sizes per Frame Size are listed on pages E-16 - E-18.

Most stock VHS Motors include a Non-Reverse Ratchet (NRR), as indicated by their Catalog Number. To order a Motor with a Self-Release Coupling (SRC), add an "N" as the last character in the Catalog Number. Example: HO50S2BLG includes NRR, HO50S2BLGN is SRC.

† All marks shown within this document are properties of their respective owners.

Revised — April 2019



# Vertical HOLLOWSHAFT® High Thrust Motors - "P" Base, Three Phase Weather Protected Type I (WPI) Premium Efficient, SINEWAVE OPTIMIZED®

## APPLICATIONS:

For use on Turbine, Mix Flow and Propeller Pumps

## FEATURES:

- Class F Insulation, Class B Rise at Full Load
- 1.15 Service Factor
- Maximum 40°C Ambient, 3,300 Feet Altitude
- 230/460 Volt Motors Suitable for 230 Volt Part Winding Start
- Premium Efficient Design
- Special Balance
- Corrosion Resistant Mill & Chemical Duty Paint
- 115 Volt Space Heater (through 250 HP)
- NRR = Non-Reverse Ratchet, SRC = Self-Release Coupling
- Refer to Page ii-iv for Guidelines & Compatibility with VFD's
- Discount Symbol: DS-7VS

HP	RPM	Voltage	Frame	Catalog Number	Type	List w/NRR	List w/SRC	NEMA Nom. Eff.	Down Thrust (lbs.)	Base Dia. (in.)	Cplg Height (in.)	Cplg BX (in.)	Cplg Key Size	Ship Wt. (lbs.)	Notesx
7-1/2	1800	230/460	213TP	HO7P2BLE	AUS	\$3,789	\$3,518	91.7	2500	10	17-9/16	1	1/4	210	
	1200	230/460	254TPH	HO7P3BLF	AUS	\$4,983	\$4,607	90.2	3800	12	23-3/8	1	1/4	265	
10	1800	230/460	215TP	HO10P2BLE	AUS	\$4,187	\$3,869	91.7	2500	10	17-9/16	1	1/4	220	
	1200	230/460	256TPH	HO10P3BLF	AUS	\$5,592	\$5,207	91.7	3800	12	23-3/8	1	1/4	300	
15	1800	230/460	254TP	HO15P2BLE	AUS	\$4,686	\$4,358	93.0	3300	10	23-3/8	1	1/4	265	
	1800	230/460	254TPA	HO15P2BLG	AUS	\$4,686	\$4,358	93.0	3300	16.5	23-3/8	1	1/4	265	
	1200	230/460	284TPA	HO15P3BLF	AUS	\$6,548	\$6,137	91.7	3800	12	24-3/4	1	1/4	305	
20	3600	230/460	254TPH	HO20P1BLF	AUS	\$4,708	\$4,061	91.0	2600	12	23-3/8	1	1/4	265	
	1800	230/460	256TPH	HO20P2BLF	AUS	\$5,122	\$4,763	93.0	3300	12	24-3/4	1	1/4	300	
	1800	230/460	256TPA	HO20P2BLG	AUS	\$5,122	\$4,763	93.0	3300	16.5	24-3/4	1	1/4	300	
	1200	230/460	286TPH	HO20P3BLG	AUS	\$7,307	\$6,838	92.4	3800	16.5	25-7/8	1	1/4	325	
25	3600	230/460	256TPH	HO25P1BLF	AUS	\$5,015	\$4,368	91.7	2600	12	23-3/8	1	1/4	300	
	1800	230/460	284TPA	HO25P2BLF	AUS	\$5,778	\$5,374	93.6	3300	12	24-3/4	1	1/4	305	
	1800	230/460	284TPH	HO25P2BLG	AUS	\$5,778	\$5,374	93.6	3300	16.5	24-3/4	1	1/4	305	
	1200	230/460	324TP	HO25P3BLG	RUS	\$8,923	\$8,383	93.0	6700	16.5	28-7/32	1	1/4	635	
30	3600	230/460	284TPA	HO30P1BLF	AUS	\$5,369	\$4,698	91.7	2600	12	24-3/4	1	1/4	305	
	1800	230/460	286TPA	HO30P2BLF	AUS	\$6,277	\$5,838	94.1	3300	12	24-3/4	1	1/4	325	
	1800	230/460	286TPH	HO30P2BLG	AUS	\$6,277	\$5,838	94.1	3300	16.5	24-3/4	1	1/4	325	
	1200	230/460	326TP	HO30P3BLG	RUS	\$9,916	\$9,296	93.6	6700	16.5	28-7/32	1-1/4	3/8	675	
40	3600	230/460	286TPA	HO40P1BLF	AUS	\$5,927	\$5,228	92.4	2600	12	24-3/4	1	1/4	325	
	1800	230/460	324TPH	HO40P2BLF	RUS	\$7,017	\$6,526	94.5	5700	12	28-7/32	1-1/4	1/4	635	
	1800	230/460	324TP	HO40P2BLG	RUS	\$7,017	\$6,526	94.5	5700	16.5	28-7/32	1-1/4	1/4	635	
	1800	460	324TP	HO40P2SLG	RUS	\$7,017	\$6,526	94.5	5700	16.5	28-7/32	1-1/4	1/4	635	PWS
	1200	230/460	364TP	HO40P3BLGX	RUS	\$12,880	\$12,124	94.1	11725	16.5	31-5/32	1-1/4	3/8	730	
50	3600	230/460	324TPH	HO50P1BLF	RUS	\$8,571	\$8,036	93.0	4600	12	28-7/32	1	1/4	635	
	1800	230/460	326TPH	HO50P2BLF	RUS	\$8,182	\$7,609	94.5	5700	12	28-7/32	1-1/4	1/4	675	
	1800	230/460	326TP	HO50P2BLG	RUS	\$8,182	\$7,609	94.5	5700	16.5	28-7/32	1-1/4	1/4	675	
	1800	460	326TP	HO50P2SLG	RUS	\$8,182	\$7,609	94.5	5700	16.5	28-7/32	1-1/4	1/4	675	PWS
60	1200	230/460	365TP	HO50P3BLGX	RUS	\$15,609	\$14,271	94.1	11725	16.5	31-5/32	1-1/4	3/8	800	
	3600	460	326TP	HO60P1SLG	RUS	\$9,841	\$9,203	93.6	4600	16.5	28-7/32	1-1/4	1/4	675	PWS
	1800	230/460	364TP	HO60P2BLG	RUS	\$9,528	\$8,861	95.0	5700	16.5	31-5/32	1-1/4	1/4	730	
	1800	460	364TP	HO60P2SLG	RUS	\$9,528	\$8,861	95.0	5700	16.5	31-5/32	1-1/4	1/4	730	PWS
	1200	460	404TP	HO60P3SLGX	RUS	\$17,329	\$16,310	94.5	13650	16.5	36-15/16	1-1/2	3/8	1110	PWS
75	3600	460	364TP	HO75P1SLG	RUS	\$11,167	\$10,374	93.6	4500	16.5	31-5/32	1-1/4	1/4	730	PWS
	1800	230/460	365TP	HO75P2BLG	RUS	\$11,327	\$10,534	95.0	5700	16.5	31-5/32	1-1/4	1/4	800	
	1800	460	365TP	HO75P2SLG	RUS	\$11,327	\$10,534	95.0	5700	16.5	31-5/32	1-1/4	1/4	800	PWS
	1200	460	405TP	HO75P3SLGX	RUS	\$19,641	\$18,444	94.5	13650	16.5	36-15/16	1-1/2	3/8	1200	PWS
100	3600	460	365TP	HO100P1SLG	RUS	\$15,284	\$14,209	93.6	4500	16.5	31-5/32	1-1/4	3/8	800	PWS
	1800	230/460	404TP	HO100P2BLG	RUS	\$14,376	\$13,370	95.4	6700	16.5	36-15/16	1-1/2	3/8	1100	
	1800	460	404TP	HO100P2SLG	RUS	\$14,376	\$13,370	95.4	6700	16.5	36-15/16	1-1/2	3/8	1100	PWS
	1800	460	404TP	HO100P2SLGX	RUS	\$14,858	\$13,818	95.4	11725	16.5	36-15/16	1-1/2	3/8	1100	PWS

† All marks shown within this document are properties of their respective owners.



VERTICAL MOTORS  
STEADY BUSHING KITS  
CONVERSION CENTER  
QUICK ENGINEERING FACTS  
FORMULAS  
LONG TERM STORAGE INFORMATION  
OPERATING CHARACTERISTICS  
DIMENSION PRINT INDEX  
DRIVE COUPLING PART NUMBERS  
DIMENSION PRINTS

# Vertical HOLLOSHAFT® High Thrust Motors - "P" Base, Three Phase Weather Protected Type I (WPI) Premium Efficient, SINEWAVE OPTIMIZED® (continued)

HP	RPM	Voltage	Frame	Catalog Number	Type	List w/NRR	List w/SRC	NEMA Nom. Eff.	Down Thrust (lbs.)	Base Dia. (in.)	Cplg Height (in.)	Cplg BX (in.)	Cplg Key Size	Ship Wt. (lbs.)	Notesx
125	1800	460	405TP	HO125P2SLG	RUS	\$17,769	\$16,330	95.4	6700	16.5	36-15/16	1-1/2	3/8	1200	PWS
	1800	460	405TP	HO125P2SLGX	RUS	\$18,387	\$16,959	95.4	11725	16.5	36-15/16	1-1/2	3/8	1200	PWS
150	1800	460	H444TP	HO150P2SLG	RUS	\$22,955	\$21,655	95.8	9800	16.5	44-25/32	1-11/16	3/8	1500	PWS
	1800	460	H444TP	HO150P2SLGX	RUS	\$23,466	\$22,166	95.8	17150	16.5	44-25/32	1-11/16	3/8	1500	PWS
	1800	460	H444TPA	HO150P2SLH	RUS	\$22,955	\$21,655	95.8	9800	20	44-25/32	1-11/16	3/8	1500	PWS
200	1800	460	H445TP	HO200P2SLG	RUS	\$28,995	\$26,935	95.8	9800	16.5	44-25/32	1-11/16	3/8	1600	PWS
	1800	460	H445TPA	HO200P2SLHX	RUS	\$29,974	\$27,933	95.8	17150	20	44-25/32	1-11/16	3/8	1600	PWS
250	1800	460	H445TPA	HO250P2SLHX	RUS	\$37,811	\$36,127	95.8	17150	20	44-25/32	1-11/16	3/8	1600	PWS
300	1800	460	447TPA	HO300P2SLHX	RUS	\$43,899	\$42,351	95.8	17150	20	49-25/32	1-11/16	3/8	2100	PWS
350	1800	460	447TPA	HO350P2SLHX	RUS	\$49,277	\$47,771	95.8	17150	20	49-25/32	1-11/16	3/8	2100	PWS
400	1800	460	449TPH	HO400P2SLHX	RUS	\$55,213	\$53,725	95.8	28500	20	49-13/16	1-15/16	1/2	2825	52,53,PWS
450	1800	460	449TPH	HO450P2SLHX	RUS	\$58,702	\$57,235	96.2	28500	20	49-13/16	1-15/16	1/2	2865	52,53,PWS
500	1800	460	449TPH	HO500P2SFLHX	RUS	\$62,906	\$61,439	96.2	28500	20	49-13/16	2-3/16	1/2	3015	52,53,PWS
	1800	460	5008PH	HO500P2SLHX	RUE	\$69,896	\$68,735	96.2	28500	20	57-1/16	2-3/16	1/2	4200	52,53,PWS
600	1800	460	5008P	HO600P2SFLJX	RUE	\$93,512	\$91,958	96.2	28500	24-1/2	57-1/16	2-3/16	1/2	4210	52,53,PWS
600	1800	460	5008P	HO600S2SLJX	RU	\$84,730	\$83,322	95.8	28500	24-1/2	57-1/16	2-3/16	1/2	4210	52,53,PWS, NNP, LA

NOTE: Alternative Coupling Sizes per Frame Size are listed on pages E-16 - E-18.  
Most stock VHS Motors include a Non-Reverse Ratchet (NRR), as indicated by their Catalog Number. To order a motor with a Self-Release Coupling (SRC), add an "N" as the last character in the Catalog Number. Example: HO50S2BLG includes NRR; HO50S2BLGN is SRC.

- Note 52 Requires minimal external thrust equal to 30% down thrust value shown
- Note 53 Synthetic Oil required
- Note LA Limited Availability
- Note NNP Non-NEMA®† Premium Rating
- Note PWS Part Winding Start

† All marks shown within this document are properties of their respective owners.



# Vertical HOLLOWSHAFT® High Thrust Motors - “P” Base, Three Phase Weather Protected Type I (WPI) Premium Efficient, Inverter Duty

## APPLICATIONS:

For use on Turbine, Mix Flow and Propeller Pumps

## FEATURES:

- Class F Insulation, Class B Rise at Full Load (Sine Wave Power)
- 1.15 Service Factor (Sine Wave Power)
- Maximum 40°C Ambient, 3,300 Feet Altitude
- 230/460 Volt Motors Suitable for 230 Volt Part Winding Start
- 30 HP & Below Can Be Rerated for 208/415 Volt, 50 Hertz Operation at 1.0 Service Factor (230/460 Volt Ratings Only)
- Premium Efficient Design
- Special Balance
- 115 Volt Space Heater (through 250 HP)
- Corrosion Resistant Mill & Chemical Duty Paint
- Inverter Duty per NEMA® MG-1 Part 31 at 1.0 Service Factor
- Shaft Grounding Ring
- Upper Insulated Bearing 400 Frame & Up
- NRR = Non-Reverse Ratchet, SRC = Self Release Coupling
- A member of the ACCU-SERIES® family of variable speed products
- Discount Symbol: DS-7VS

HP	RPM	Voltage	Frame	Catalog Number	Type	List w/NRR	List w/SRC	NEMA Nom. Eff.	Down Thrust (lbs.)	Base Dia (in.)	Cplg Height (in.)	Cplg BX (in.)	Cplg Key Size	Ship Wt. (lbs.)	Notes
15	1800	230/460	254TP	HO15V2BLE	AUSI	\$5,226	\$4,897	93.0	3300	10	23-3/8	1	1/4	265	51,97,D
	1800	575	254TP	HO15V2GLE	AUSI	\$5,226	\$4,897	93.0	3300	10	23-3/8	1	1/4	265	51,97,D
20	1800	230/460	256TPH	HO20V2BLF	AUSI	\$5,728	\$5,352	93.0	3300	12	24-3/4	1	1/4	300	51,97,D
	1800	230/460	256TPA	HO20V2BLG	AUSI	\$5,728	\$5,352	93.0	3300	16.5	24-3/4	1	1/4	300	51,97,D
	1800	575	256TP	HO20V2GLE	AUSI	\$5,728	\$5,352	93.0	3300	10	24-3/4	1	1/4	300	51,97,D
25	1800	230/460	284TPA	HO25V2BLF	AUSI	\$6,456	\$6,038	93.6	3300	12	24-3/4	1	1/4	305	51,97,D
	1800	230/460	284TPH	HO25V2BLG	AUSI	\$6,456	\$6,038	93.6	3300	16.5	24-3/4	1	1/4	305	51,97,D
	1800	575	284TP	HO25V2GLE	AUSI	\$6,456	\$6,038	93.6	3300	10	24-3/4	1	1/4	305	51,97,D
30	1800	230/460	286TPA	HO30V2BLF	AUSI	\$7,024	\$6,559	94.1	3300	12	24-3/4	1	1/4	325	51,97,D
	1800	230/460	286TPH	HO30V2BLG	AUSI	\$7,024	\$6,559	94.1	3300	16.5	24-3/4	1	1/4	325	51,97,D
	1800	575	286TP	HO30V2GLE	AUSI	\$7,024	\$6,559	94.1	3300	10	24-3/4	1	1/4	325	51,97,D
40	1800	230/460	324TPH	HO40V2BLF	RUSI	\$7,779	\$7,296	94.5	5700	12	28-7/32	1-1/4	1/4	635	51,97,D
	1800	230/460	324TP	HO40V2BLG	RUSI	\$7,779	\$7,296	94.5	5700	16.5	28-7/32	1-1/4	1/4	635	51,97,D
	1800	575	324TP	HO40V2GLG	RUSI	\$7,779	\$7,296	94.5	5700	16.5	28-7/32	1-1/4	1/4	635	51,97,D
50	1800	230/460	326TP	HO50V2BLG	RUSI	\$8,894	\$8,317	94.5	5700	16.5	28-7/32	1-1/4	1/4	675	51,97,D
	1800	575	326TP	HO50V2GLG	RUSI	\$8,894	\$8,317	94.5	5700	16.5	28-7/32	1-1/4	1/4	675	51,97,D
60	1800	460	364TP	HO60V2SLG	RUSI	\$10,528	\$9,866	95.0	5700	16.5	31-5/32	1-1/4	1/4	730	51,97,D,PWS
	1800	575	364TP	HO60V2GLG	RUSI	\$10,528	\$9,866	95.0	5700	16.5	31-5/32	1-1/4	1/4	730	51,97,D
75	1800	460	365TP	HO75V2SLG	RUSI	\$12,312	\$11,505	95.0	5700	16.5	31-5/32	1-1/4	1/4	800	51,97,D,PWS
	1800	575	365TP	HO75V2GLG	RUSI	\$12,312	\$11,505	95.0	5700	16.5	31-5/32	1-1/4	1/4	800	51,97,D
100	1800	460	404TP	HO100V2SLG	RUSI	\$15,885	\$14,866	95.4	6700	16.5	36-15/16	1-1/2	3/8	1110	51,97,E,PWS
	1800	460	404TP	HO100V2SLGX	RUSI	\$16,418	\$15,399	95.4	11725	16.5	36-15/16	1-1/2	3/8	1110	51,97,E,PWS
	1800	575	404TP	HO100V2GLG	RUSI	\$15,885	\$14,866	95.4	6700	16.5	36-15/16	1-1/2	3/8	1100	51,97,E
125	1800	460	405TP	HO125V2SLG	RUSI	\$18,509	\$17,275	95.4	6700	16.5	36-15/16	1-1/2	3/8	1200	51,97,E,PWS
	1800	460	405TP	HO125V2SLGX	RUSI	\$19,153	\$17,919	95.4	11725	16.5	36-15/16	1-1/2	3/8	1200	51,97,E,PWS
	1800	575	405TP	HO125V2GLG	RUSI	\$18,509	\$17,275	95.4	6700	16.5	36-15/16	1-1/2	3/8	1200	51,97,E
150	1800	460	H444TP	HO150V2SLG	RUSI	\$24,562	\$23,262	95.8	9800	16.5	44-25/32	1-11/16	3/8	1500	51,97,E,PWS
	1800	460	H444TP	HO150V2SLGX	RUSI	\$25,109	\$23,809	95.8	17150	16.5	44-25/32	1-11/16	3/8	1500	51,97,E,PWS
	1800	575	H444TP	HO150V2GLG	RUSI	\$24,562	\$23,262	95.8	9800	16.5	44-25/32	1-11/16	3/8	1500	51,97,E
200	1800	460	H445TPA	HO200V2SLH	RUSI	\$31,516	\$29,746	95.8	9800	20	44-25/32	1-11/16	3/8	1600	51,97,E,PWS
	1800	460	H445TPA	HO200V2SLHX	RUSI	\$32,580	\$30,810	95.8	17150	20	44-25/32	1-11/16	3/8	1600	51,97,E,PWS
	1800	575	H445TP	HO200V2GLG	RUSI	\$31,516	\$29,746	95.8	9800	16.5	44-25/32	1-11/16	3/8	1600	51,97,E
250	1800	460	H445TPA	HO250V2SLH	RUSI	\$39,399	\$38,066	95.8	9800	20	44-25/32	1-11/16	3/8	1600	51,97,E,PWS
	1800	460	H445TPA	HO250V2SLHX	RUSI	\$40,657	\$39,324	95.8	17150	20	44-25/32	1-11/16	3/8	1600	51,97,E,PWS
	1800	575	H445TP	HO250V2GLG	RUSI	\$39,399	\$38,066	95.8	9800	16.5	44-25/32	1-11/16	3/8	1600	51,97,E
300	1800	460	447TPA	HO300V2SLH	RUSI	\$45,704	\$44,458	95.8	9800	20	49-25/32	1-11/16	3/8	2200	51,97,E,PWS
	1800	460	447TPA	HO300V2SLHX	RUSI	\$47,203	\$45,957	95.8	17150	20	49-25/32	1-11/16	3/8	2200	51,97,E,PWS
	1800	575	447TP	HO300V2GLG	RUSI	\$45,704	\$44,458	95.8	9800	16.5	49-25/32	1-11/16	3/8	2200	51,97,E

† All marks shown within this document are properties of their respective owners.



# Vertical HOLLOWSHAFT® High Thrust Motors - "P" Base, Three Phase Weather Protected Type I (WPI) Premium Efficient, Inverter Duty *(continued)*

HP	RPM	Voltage	Frame	Catalog Number	Type	List w/NRR	List w/SRC	NEMA Nom. Eff.	Down Thrust (lbs.)	Base Dia (in.)	Cplg Height (in.)	Cplg BX (in.)	Cplg Key Size	Ship Wt. (lbs.)	Notes
350	1800	460	447TPA	HO350V2SLH	RUSI	\$50,683	\$49,437	95.8	9800	20	49-25/32	1-11/16	3/8	2200	51,97,E,PWS
	1800	460	447TPA	HO350V2SLHX	RUSI	\$52,422	\$51,176	95.8	17150	20	49-25/32	1-11/16	3/8	2200	51,97,E,PWS
	1800	575	447TP	HO350V2GLG	RUSI	\$50,683	\$49,437	95.8	9800	16.5	49-25/32	1-11/16	3/8	2200	51,97,E
400	1800	460	449TPH	HO400V2SLH	RUSI	\$57,514	\$56,268	96.2	9500	20	49-13/16	1-15/16	1/2	2800	51,97,E,PWS
	1800	460	449TPH	HO400V2SLHX	RUSI	\$61,734	\$60,488	96.2	28500	20	49-13/16	1-15/16	1/2	2800	V10,PWS
	1800	575	449TP	HO400V2GLJ	RUSI	\$57,514	\$56,268	95.8	9500	24.5	49-13/16	1-15/16	1/2	2800	51,97,E
450	1800	460	449TPH	HO450V2SLH	RUSI	\$61,148	\$59,871	96.2	9500	20	49-13/16	1-15/16	1/2	2800	51,97,E,PWS
	1800	460	449TPH	HO450V2SLHX	RUSI	\$65,638	\$64,361	96.2	28500	20	49-13/16	1-15/16	1/2	2800	V10,PWS
500	1800	460	449TPH	HO500V2SFLH	RUSI	\$66,218	\$64,941	96.2	9500	20	49-13/16	2-3/16	1/2	3015	51,97,E,PWS
	1800	460	449TPH	HO500V2SFLHX	RUSI	\$71,060	\$69,783	96.2	28500	20	49-13/16	2-3/16	1/2	3015	V10,PWS
	1800	460	5008PH	HO500V2SLH	RUEI	\$73,575	\$71,736	96.2	9500	20	57-1/16	2-3/16	1/2	4200	51,97,E,PWS
	1800	460	5008PH	HO500V2SLHX	RUEI	\$78,955	\$77,116	96.2	28500	20	57-1/16	2-3/16	1/2	4200	V10,PWS
600	1800	460	5008P	HO600V2SFLJX	RUEI	\$99,481	\$97,530	96.2	28500	24.5	57-1/16	2-3/16	1/2	4200	V10,PWS

NOTE: Alternative Coupling Sizes per Frame Size are listed on pages Page E-16 - E-18.

Most stock VHS Motors include a Non-Reverse Ratchet (NRR), as indicated by their Catalog Number. To order a motor with a Self-Release Coupling (SRC), add an "N" as the last character in the Catalog Number. Example: HO50S2BLG includes NRR; HO50S2BLGN is SRC.

An "X" as the last character in the Catalog number indicates Extra High Thrust.

- Note 51 Equipped with Winding Thermostat
- Note 97 Inverter Duty with Inverter Grade Insulation
- Note D Includes internal shaft grounding ring
- Note E Includes internal shaft grounding ring and upper insulated bearing

- Note PWS Part Winding Start
- Note V10 Equipped with Winding thermostat, Requires minimal external thrust equal to 30% down thrust for values showed, Synthetic Oil required, Inverter Duty with Inverter Grade insulation, and Includes internal shaft grounding ring and upper insulated bearing

† All marks shown within this document are properties of their respective owners.



# Vertical HOLLOSHAFT® High Thrust Motors - "P" Base, Three Phase Totally Enclosed Fan Cooled (TEFC) Premium Efficient, SINEWAVE OPTIMIZED®

## APPLICATIONS:

For use on turbine, mix flow and propeller pumps

## FEATURES:

- Class F Insulation, Class B Rise at Full Load
- 1.15 Service Factor
- Maximum 40°C Ambient, 3,300 Feet Altitude
- 230/460 Volt Motors Suitable for 230V PWS on 250-320 Frame
- 30 HP & Below Can Be Rerated for 208/415 Volt, 50 Hertz Operation at 1.0 Service Factor
- Premium Efficient Design
- Special Balance
- 115 Volt Space Heater (through 250 HP)
- Corrosion Resistant Mill & Chemical Duty Paint
- NRR = Non-Reverse Ratchet, SRC = Self-Release Coupling
- Refer to Page ii-iv for Guidelines & Compatibility with VFD's
- Discount Symbol: DS-7VS

HP	RPM	Volts	Frame	Catalog Number	Type	List w/NRR	List w/SRC	NEMA Nom. Eff.	Down Thrust (lbs.)	Base Dia. (in.)	Cplg Height (in.)	Cplg BX (in.)	Cplg Key Size	Ship Wt. (lbs.)	Notes
5	3600	230/460	184TP	HT5P1BLE	TUS	\$3,666	\$3,333	88.5	2200	10	17-9/16	1	1/4	170	—
	1800	230/460	184TP	HT5P2BLE	TUS	\$3,443	\$3,110	90.2	2500	10	17-9/16	1	1/4	170	—
7 1/2	3600	230/460	H213TP	HT7P1BLE	TUS	\$3,807	\$3,464	89.5	2200	10	18-13/16	1	1/4	210	—
	1800	230/460	H213TP	HT7P2BLE	TUS	\$3,731	\$3,388	91.7	2500	10	18-13/16	1	1/4	210	—
10	3600	230/460	H215TP	HT10P1BLE	TUS	\$4,137	\$3,785	90.2	2200	10	18-13/16	1	1/4	220	—
	1800	230/460	H215TP	HT10P2BLE	TUS	\$4,052	\$3,700	91.7	2500	10	18-13/16	1	1/4	220	—
15	3600	230/460	H215TP	HT15P1BLE	TUS	\$4,650	\$4,237	91.0	2200	10	18-13/16	1	1/4	220	14
	1800	230/460	254TP	HT15P2BLE	TUS	\$5,650	\$5,227	92.4	3300	10	22-15/16	1	1/4	265	—
20	1800	230/460	256TP	HT20P2BLE	TUS	\$6,290	\$5,802	93.0	3300	10	22-15/16	1	1/4	300	—
25	1800	230/460	284TPA	HT25P2BLF	TUS	\$7,096	\$6,551	93.6	3300	12	26-9/16	1	1/4	320	—
30	1800	230/460	286TPA	HT30P2BLF	TUS	\$7,819	\$7,209	93.6	3300	12	26-9/16	1	1/4	330	—
40	1800	230/460	324TP	HT40P2BLG	TUS	\$9,902	\$9,221	94.5	4500	16-1/2	28-1/2	1-1/4	1/4	665	—
50	1800	230/460	326TP	HT50P2BLG	TUS	\$11,426	\$10,618	94.5	4500	16-1/2	28-1/2	1-1/4	1/4	690	—
60	1800	460	364TP	HT60P2CLG	TUS	\$14,172	\$13,172	95.0	5600	16-1/2	30	1-1/4	1/4	900	—
75	1800	460	365TP	HT75P2CLG	TUS	\$16,778	\$15,567	95.4	5600	16-1/2	30	1-1/4	1/4	925	—
100	1800	460	405TP	HT100P2CLG	TUS	\$22,580	\$20,946	95.4	7000	16-1/2	39-15/16	1-1/2	3/8	1500	—
125	1800	460	444TP	HT125P2CLG	TUS	\$31,411	\$29,542	95.4	9300	16-1/2	42-1/2	1-1/2	3/8	1800	—
150	1800	460	447TP	HT150P2CLG	TUS	\$37,074	\$34,792	95.8	9300	16-1/2	46	1-1/2	3/8	2300	—
200	1800	460	447TP	HT200P2CLG	TUS	\$49,499	\$46,311	96.2	9300	16-1/2	46	1-11/16	3/8	2300	—
250	1800	460	449TP	HT250P2CLJX	JUE	\$58,355	\$57,003	96.2	15400	24-1/2	56-7/8	1-11/16	3/8	3600	—
300	1800	460	449TP	HT300P2CLJX	JUE	\$64,200	\$62,688	96.2	15400	24-1/2	56-7/8	1-11/16	3/8	3800	—

NOTE: Alternative Coupling Sizes per Frame Size are listed on pages E-16 - E-18.

Most stock VHS Motors include a Non-Reverse Ratchet (NRR), as indicated by their Catalog Number. To order a motor with a Self-Release Coupling (SRC), add an "N" as the last character in the Catalog Number. Example: HO50S2BLG includes NRR; HO50S2BLGN is SRC.

Note 14 NEMA Design A

† All marks shown within this document are properties of their respective owners.





# Vertical HOLLOWSHAFT® High Thrust Motors - "P" Base, Three Phase TEFC CORRO-DUTY® Premium Efficient, Inverter Duty

## APPLICATIONS:

For use on turbine, mix flow and propeller pumps

## FEATURES:

- Class H Insulation, Class B Rise at Full Load (Sine Wave Power)
- 1.15 Service Factor (Sine Wave Power)
- Maximum 40°C Ambient, 3,300 Feet Altitude
- 230/460 Volt Motors Suitable for 230V PWS on 250-320 Frame
- Premium Efficient Design
- Special Balance
- 115 Volt Space Heater (through 250 HP)
- CORRO-DUTY® - All Cast Iron Construction
- Inverter Duty per NEMA® MG-1 Part 31 at 1.0 Service Factor
- Shaft Grounding Ring
- Upper Insulated Bearing 400 Frame & Up
- NRR = Non-Reverse Ratchet, SRC = Self Release Coupling
- A member of the ACCU-SERIES® family of variable speed products
- Discount Symbol: DS-7VS

HP	RPM	Volts	Frame	Catalog Number	Type	List w/NRR	List w/SRC	NEMA Nom. Eff.	Down Thrust (lbs.)	Base Dia. (in.)	Cplg Height (in.)	Cplg BX (in.)	Cplg Key Size	Ship Wt. (lbs.)	Notes
5	3600	230/460	184TP	CHT5V1BLE	TUCI	\$3,893	\$3,560	88.5	2200	10	17-1/2	1	1/4	180	51,97,D
	3600	575	184TP	CHT5V1GLE	TUCI	\$3,893	\$3,560	88.5	2200	10	17-1/2	1	1/4	180	51,97,D
	1800	230/460	184TP	CHT5V2BLE	TUCI	\$3,654	\$3,321	89.5	2500	10	17-1/2	1	1/4	180	51,97,D
	1800	575	184TP	CHT5V2GLE	TUCI	\$3,654	\$3,321	89.5	2500	10	17-1/2	1	1/4	180	51,97,D
7 1/2	3600	230/460	213TP	CHT7V1BLE	TUCI	\$4,044	\$3,701	89.5	2200	10	17-1/2	1	1/4	220	51,97,D
	3600	575	213TP	CHT7V1GLE	TUCI	\$4,044	\$3,701	89.5	2200	10	17-1/2	1	1/4	220	51,97,D
	1800	230/460	213TP	CHT7V2BLE	TUCI	\$3,962	\$3,619	91.7	2500	10	17-1/2	1	1/4	220	51,97,D
	1800	575	213TP	CHT7V2GLE	TUCI	\$3,962	\$3,619	91.7	2500	10	17-1/2	1	1/4	220	51,97,D
10	3600	230/460	215TP	CHT10V1BLE	TUCI	\$4,398	\$4,046	90.2	2200	10	17-1/2	1	1/4	230	51,97,D
	3600	575	215TP	CHT10V1GLE	TUCI	\$4,398	\$4,046	90.2	2200	10	17-1/2	1	1/4	230	51,97,D
	1800	230/460	215TP	CHT10V2BLE	TUCI	\$4,307	\$3,955	91.7	2500	10	17-1/2	1	1/4	230	51,97,D
	1800	575	215TP	CHT10V2GLE	TUCI	\$4,307	\$3,955	91.7	2500	10	17-1/2	1	1/4	230	51,97,D
15	3600	230/460	254TP	CHT15V1BLE	TUCI	\$4,945	\$4,532	91.0	3300	10	22-15/16	1	1/4	395	51,97,D
	3600	575	254TP	CHT15V1GLE	TUCI	\$4,945	\$4,532	91.0	3300	10	22-15/16	1	1/4	395	51,97,D
	1800	230/460	254TP	CHT15V2BLE	TUCI	\$6,019	\$5,596	92.4	3300	10	22-15/16	1	1/4	395	51,97,D
	1800	575	254TP	CHT15V2GLE	TUCI	\$6,019	\$5,596	92.4	3300	10	22-15/16	1	1/4	395	51,97,D
20	1800	230/460	256TP	CHT20V2BLE	TUCI	\$6,703	\$6,215	93.0	3300	10	22-15/16	1	1/4	405	51,97,D
	1800	575	256TP	CHT20V2GLE	TUCI	\$6,703	\$6,215	93.0	3300	10	22-15/16	1	1/4	405	51,97,D
25	1800	230/460	284TPA	CHT25V2BLF	TUCI	\$7,565	\$7,020	93.6	3300	12	26-9/16	1	1/4	500	51,97,D
	1800	575	284TPA	CHT25V2GLF	TUCI	\$7,565	\$7,020	93.6	3300	12	26-9/16	1	1/4	500	51,97,D
30	1800	230/460	286TPA	CHT30V2BLF	TUCI	\$8,337	\$7,727	93.6	3300	12	26-9/16	1	1/4	520	51,97,D
	1800	575	286TPA	CHT30V2GLF	TUCI	\$8,337	\$7,727	93.6	3300	12	26-9/16	1	1/4	520	51,97,D
40	1800	230/460	324TP	CHT40V2BLG	TUCI	\$10,564	\$9,883	94.5	4500	16-1/2	28-1/2	1-1/2	3/8	740	51,97,D
	1800	575	324TP	CHT40V2GLG	TUCI	\$10,564	\$9,883	94.1	4500	16-1/2	28-1/2	1-1/2	3/8	740	51,97,D
50	1800	230/460	326TP	CHT50V2BLG	TUCI	\$12,194	\$11,386	94.5	4500	16-1/2	28-1/2	1-1/2	3/8	750	51,97,D
	1800	575	326TP	CHT50V2GLG	TUCI	\$12,194	\$11,386	94.5	4500	16-1/2	28-1/2	1-1/2	3/8	750	51,97,D
60	1800	460	364TP	CHT60V2CLG	TUCI	\$15,131	\$14,131	95.0	5600	16-1/2	30	1-1/4	1/4	925	51,97,D
	1800	575	364TP	CHT60V2GLG	TUCI	\$15,131	\$14,131	95.0	5600	16-1/2	30	1-1/4	1/4	925	51,97,D
75	1800	460	365TP	CHT75V2CLG	TUCI	\$17,917	\$16,706	95.4	5600	16-1/2	30	1-1/4	1/4	940	51,97,D
	1800	575	365TP	CHT75V2GLG	TUCI	\$17,917	\$16,706	95.4	5600	16-1/2	30	1-1/4	1/4	940	51,97,D
100	1800	460	405TP	CHT100V2CLG	TUCI	\$24,122	\$22,488	95.4	7000	16-1/2	39-15/16	1-1/2	3/8	1600	51,97,E
	1800	575	405TP	CHT100V2GLG	TUCI	\$24,122	\$22,488	95.4	7000	16-1/2	39-15/16	1-1/2	3/8	1600	51,97,E
125	1800	460	444TP	CHT125V2CLG	TUCI	\$33,598	\$31,729	95.4	9300	16-1/2	42-1/2	1-1/2	3/8	1900	51,97,E
	1800	575	444TP	CHT125V2GLG	TUCI	\$33,598	\$31,729	95.4	9300	16-1/2	42-1/2	1-1/2	3/8	1900	51,97,E
150	1800	460	447TP	CHT150V2CLG	TUCI	\$39,655	\$37,373	95.8	9300	16-1/2	46	1-1/2	3/8	2300	51,97,E
	1800	575	447TP	CHT150V2GLG	TUCI	\$39,655	\$37,373	95.8	9300	16-1/2	46	1-1/2	3/8	2300	51,97,E
200	1800	460	447TP	CHT200V2CLG	TUCI	\$52,944	\$49,756	96.2	9300	16-1/2	46	1-11/16	3/8	2300	51,97,E
	1800	575	447TP	CHT200V2GLG	TUCI	\$52,944	\$49,756	96.2	9300	16-1/2	46	1-11/16	3/8	2300	51,97,E
250	1800	460	449TP	CHT250V2CLJX	JUCEI	\$61,776	\$60,424	96.2	15400	24-1/2	56-7/8	1-11/16	3/8	3800	51,97,E
	1800	575	449TP	CHT250V2GLJX	JUCEI	\$61,776	\$60,424	96.2	15400	24-1/2	56-7/8	1-11/16	3/8	3800	51,97,E
300	1800	460	449TP	CHT300V2CLJX	JUCEI	\$67,994	\$66,482	96.2	15400	24-1/2	56-7/8	1-15/16	1/2	3900	51,97,E
	1800	575	449TP	CHT300V2GLJX	JUCEI	\$67,994	\$66,482	96.2	15400	24-1/2	56-7/8	1-15/16	1/2	3900	51,97,E

NOTE: Alternative Coupling Sizes per Frame Size are listed on pages E-16 - E-18.

Most stock VHS Motors include a Non-Reverse Ratchet (NRR), as indicated by their Catalog Number. To order a motor with a Self-Release Coupling (SRC), add an "N" as the last character in the Catalog Number. Example: HO50S2BLG includes NRR; HO50S2BLGN is SRC.

- Note 51 Equipped with Winding Thermostat  
 Note 97 Inverter Duty with Inverter Grade Insulation  
 Note D Includes internal shaft grounding ring  
 Note E Includes internal shaft grounding ring and upper insulated bearing

† All marks shown within this document are properties of their respective owners.



Revised — April 2019

# Vertical HOLLOSHAFT® High Thrust Motors - "P" Base, Three Phase Weather Protected Type I (WPI) International Duty

## APPLICATIONS:

For use on Turbine, Mix Flow and Propeller Pumps

## FEATURES:

- Class F Insulation, Class B Rise at Full Load
- 1.15 Service Factor
- Maximum 50°C Ambient, 3,300 Feet Altitude
- 60Hz Premium Efficient (IE3) Design
- 50Hz Energy Efficient (IE2) Design
- NEMA®1 Design B
- Corrosion Resistant Mill & Chemical Duty Paint
- Drive End Shaft Slinger
- 230 Volt Space Heater
- Stainless Steel Nameplate
- NRR = Non-Reverse Ratchet, SRC = Self-Release Coupling
- Refer to Page ii-iv for Guidelines & Compatibility with VFD's
- Discount Symbol: DS-7VS

## 60 Hz, 220/380-440 Volt, 12 Lead Wye-Delta

HP	RPM	Voltage	Frame	Catalog Number	Type	List w/NRR	List w/SRC	NEMA Nom. Eff.	Down Thrust (lbs.)	Base Dia. (in.)	Cplg Height (in.)	Cplg BX (in.)	Cplg Key Size	Ship Wt. (lbs.)	Notes
50	1800	220/380-440	326TP	HO50P2RLG	RUS	\$9,000	\$8,423	94.5	5700	16.5	28-7/32	1-3/16	1/4	675	53
60	1800	220/380-440	364TP	HO60P2RLG	RUS	\$10,480	\$9,818	95.0	5700	16.5	31-5/32	1-3/16	1/4	730	53
75	1800	220/380-440	365TP	HO75P2RLG	RUS	\$12,460	\$11,652	95.4	5700	16.5	31-5/32	1-3/16	1/4	800	14,53
100	1800	220/380-440	404TP	HO100P2RLG	RUS	\$15,814	\$14,795	95.4	6700	16.5	36-15/16	1-3/16	1/4	1110	53
125	1800	220/380-440	405TP	HO125P2RLG	RUS	\$19,546	\$18,311	95.4	6700	16.5	36-15/16	1-1/2	3/8	1200	53
150	1800	220/380-440	H444TP	HO150P2RLG	RUS	\$25,251	\$23,951	95.8	9800	16.5	44-25/32	1-1/2	3/8	1500	53
200	1800	220/380-440	H445TP	HO200P2RLG	RUS	\$31,851	\$30,504	96.2	9800	16.5	44-25/32	1-1/2	3/8	1600	53
300	1800	220/380-440	447TPA	HO300P2RLHX	RUS	\$48,289	\$46,730	96.2	17150	20	49-25/32	1-11/16	3/8	2200	53

## 50 Hz, 380-415 Volt, 6 Lead Wye-Delta

HP	RPM	Voltage	Frame	Catalog Number	Type	List w/NRR	List w/SRC	NEMA Nom. Eff.	Down Thrust (lbs.)	Base Dia. (in.)	Cplg Height (in.)	Cplg BX (in.)	Cplg Key Size	Ship Wt. (lbs.)	Notes
50	1500	380-415	326TP	HO50E2TLG	RUS	\$9,282	\$8,733	92.7	5700	16.5	28-7/32	1-3/16	1/4	675	53
60	1500	380-415	364TP	HO60E2TLG	RUS	\$10,823	\$10,195	93.1	5700	16.5	31-5/32	1-3/16	1/4	730	53
75	1500	380-415	404TP	HO75E2TLG	RUS	\$14,170	\$13,202	93.5	6700	16.5	36-15/16	1-3/16	1/4	1110	53
100	1500	380-415	404TP	HO100E2TLG	RUS	\$16,294	\$15,326	94.0	6700	16.5	36-15/16	1-3/16	1/4	1110	53
125	1500	380-415	H444TP	HO125E2TLG	RUS	\$22,627	\$21,392	94.3	9800	16.5	44-25/32	1-1/2	3/8	1500	53
150	1500	380-415	H444TP	HO150E2TLG	RUS	\$26,046	\$24,811	94.5	9800	16.5	44-25/32	1-1/2	3/8	1500	53
200	1500	380-415	H445TP	HO200E2TLG	RUS	\$32,802	\$31,522	94.9	9800	16.5	44-25/32	1-1/2	3/8	1600	53
250	1500	380-415	447TPA	HO250E2TLH	RUS	\$48,571	\$47,090	95.1	9800	20	49-25/32	1-11/16	3/8	2200	53
300	1500	380-415	449TPH	HO300E2TLH	RUS	\$54,422	\$52,930	95.1	9500	20	49-13/16	1-11/16	3/8	2800	53
350	1500	380-415	449TPH	HO350E2TLH	RUS	\$57,861	\$56,369	95.1	9500	20	49-13/16	1-11/16	3/8	2800	53

NOTE: Alternative Coupling Sizes per Frame Size are listed on pages E-16 - E-18.

Most stock VHS Motors include a Non-Reverse Ratchet (NRR), as indicated by their Catalog Number. To order a motor with a Self-Release Coupling (SRC), add an "N" as the last character in the Catalog Number. Example: HO50S2BLG includes NRR; HO50S2BLGN is SRC.

Note 14 NEMA Design A

Note 53 Synthetic Oil required





# Vertical Solid Shaft Normal Thrust - "P" Base Three Phase, WPI, Premium Efficient

## APPLICATIONS:

For use on vertical end suction, short couple pumps, centrifugal and non-clog pumps.

## FEATURES:

- 30HP & Below can be Rerated for 208/415 Volt, 50 Hertz Operation at 1.0 Service Factor
- Class F Insulation, Class B Rise at Full Load
- 40°C Ambient, NEMA<sup>†</sup> Design B Performance
- 230/460 Volt Motors Suitable for 230 Volt Part Winding Start
- Refer to Page ii-iv for Suitability of IHP Motors on Variable Frequency Drives
- 1.15 Service Factor (Sine Wave), 40°C Ambient
- Corrosion Resistant Mill & Chemical Duty Paint
- Discount Symbol: DS-7NS

HP	RPM	Voltage	Frame	Catalog Number	Type	List	NEMA Nom. Eff.	Down Thrust (lbs.)	Base Dia. (in.)	Ship Wt. (lbs.)	Notes
3	1800	230/460	182VP	NO3P2BE	AVS	\$1,716	89.5	390	10	150	
5	1800	230/460	184VP	NO5P2BE	AVS	\$2,638	89.5	490	10	170	
7-1/2	1800	230/460	213VP	NO7P2BE	AVS	\$3,070	91.0	560	10	210	
10	1800	230/460	215VP	NO10P2BE	AVS	\$3,448	91.7	640	10	220	
15	1800	230/460	254VP	NO15P2BE	AVS	\$3,966	93.0	640	10	265	
20	1800	230/460	256VP	NO20P2BE	AVS	\$4,526	93.0	640	10	300	
25	1800	230/460	284VPZ	NO25P2BE	AVS	\$4,851	93.6	640	10	305	
30	1800	230/460	286VPZ	NO30P2BE	AVS	\$5,455	94.1	640	10	325	
40	1800	230/460	324VP	NO40P2BG	RVS	\$5,793	94.1	640	16-1/2	635	
50	1800	230/460	326VP	NO50P2BG	RVS	\$6,873	94.5	640	16-1/2	675	
100	1800	230/460	404VPZ	NO100P2BG	RVS	\$11,700	95.4	720	16-1/2	1110	
125	1800	230/460	405VPZ	NO125P2BG	RVS	\$14,134	95.4	720	16-1/2	1200	



# Vertical Solid Shaft Normal Thrust P Base, Normal Thrust, Three Phase Totally Enclosed Fan Cooled (TEFC), CORRO-DUTY® NEMA®† Premium Efficient - IE3

## APPLICATIONS:

For pulp & paper, mill & chemical and any other severe duty environments found in the process industries.

## FEATURES:

- Class F Insulation, Class B Rise At Full Load On 60 Hertz Sine Wave Power
- All Cast Iron Construction (Steel Frame On 140 Frame)
- Corrosion Resistant Mill & Chemical Duty Paint
- Stainless Steel Nameplate (with "CE" Mark)
- Shaft Slinger On Both Ends For IP54 Protection
- Type HP Shaft And Shaft/Flange Tolerances per NEMA®† MG1-18.252
- Regreasable Bearings 140 Frame & Up, Lifting Provisions 180 Frame & Up
- 40°C Ambient, NEMA®† Design B Performance On 60 Hertz Sine Wave Power
- 50 Hz. rated at 190/380V (140-250 Frame) or 380V (280 Frame & Larger)
- 1.15 Service Factor @ 60 Hz.
- Special Balance (< 0.08 In/Sec Vibration)
- Upper Thrust Bearing
- Open Bearings 180-447 (Double Shielded Bearings on 140 Frame)
- Steel Drip Cover (Cast Iron on 140 Frame)
- Cast Iron Inner Bearing Caps (180 Frame & Larger)
- Condensation Drain With Threaded Brass Breather Plug
- Oversized Cast Iron Conduit Box - 1 Size Larger Than NEMA®† Standard
- Zinc Plated Hardware
- Discount Symbol: DS-7CE

HP	RPM	Voltage	Frame	Catalog Number	List	Down Thrust (lbs)	Base Dia. (In)	NEMA Nom. Eff.	Full Load Amps	Ship Wt. (lbs.)	Notes
3	3600	208-230/460	182HP	CNT3P1DE	\$1,459	300	10	87.5	8.4-7.8/3.9	165	03
	1800	208-230/460	182HP	CNT3P2DE	\$1,327	420	10	89.5	8.4-7.8/3.9	165	03
5	3600	208-230/460	184HP	CNT5P1DE	\$1,745	300	10	88.5	13.4-12.2/6.1	180	03
	1800	208-230/460	184HP	CNT5P2DE	\$1,489	420	10	89.5	13.7-12.5/6.3	180	03
7 1/2	3600	208-230/460	213HP	CNT7P1DE	\$2,165	460	10	91.0	19.9-17.8/8.9	220	03
	1800	208-230/460	213HP	CNT7P2DE	\$1,997	635	10	91.7	20.0-18.5/9.3	220	03
10	3600	208-230/460	215HP	CNT10P1DE	\$2,465	460	10	91.0	26.4-23.5/11.8	230	03
	1800	208-230/460	215HP	CNT10P2DE	\$2,326	635	10	91.7	26.5-23.9/12.0	230	03
15	3600	208-230/460	254HP	CNT15P1DE	\$3,140	800	10	91.0	40.0-35.0/17.5	395	03
	1800	208-230/460	254HP	CNT15P2DE	\$2,875	1110	10	92.4	40.0-37.0/18.4	395	03
20	3600	208-230/460	256HP	CNT20P1DE	\$3,770	800	10	91.0	53.0-46.0/23.1	405	03
	1800	208-230/460	256HP	CNT20P2DE	\$3,427	1110	10	93.0	52.0-47.0/23.5	405	03
25	3600	460	284HP	CNT25P1FE	\$4,696	940	10	91.7	29.4	500	03
	1800	460	284HP	CNT25P2FE	\$4,212	1295	10	93.6	29.1	500	03
30	3600	460	284HP	CNT30P1FE	\$5,369	940	10	91.7	34	520	03
	1800	460	286HP	CNT30P2FE	\$4,780	1295	10	93.6	34	520	03
40	3600	460	324HP	CNT40P1FG	\$6,698	1090	16-1/2	92.4	46	740	03
	1800	460	324HP	CNT40P2FG	\$6,020	1395	16-1/2	94.1	46	740	03
50	3600	460	326HP	CNT50P1FG	\$8,320	1090	16-1/2	93.0	56	750	03
	1800	460	326HP	CNT50P2FG	\$7,154	1395	16-1/2	94.5	56	750	03
60	3600	460	364HP	CNT60P1FG	\$11,077	1360	16-1/2	93.6	68	925	03
	1800	460	364HP	CNT60P2FG	\$10,294	1800	16-1/2	95.0	69	925	03
75	3600	460	365HP	CNT75P1FG	\$13,571	1360	16-1/2	93.6	83	940	03
	1800	460	365HP	CNT75P2FG	\$12,667	1800	16-1/2	95.4	84	940	03
100	3600	460	405HP	CNT100P1FG	\$18,448	1825	16-1/2	94.5	112	1600	03
	1800	460	405HP	CNT100P2FG	\$16,125	2300	16-1/2	95.4	113	1600	03
125	3600	460	444HP	CNT125P1FG	\$22,380	1210	16-1/2	95.8	142	1900	03
	1800	460	444HP	CNT125P2FG	\$19,430	1530	16-1/2	95.4	147	1900	03
150	3600	460	445HP	CNT150P1FG	\$26,988	1210	16-1/2	95.8	171	2000	03
	1800	460	445HP	CNT150P2FG	\$22,614	1530	16-1/2	95.8	171	2000	03
200	3600	460	447HP	CNT200P1FG	\$33,720	1210	16-1/2	96.2	217	2300	03
	1800	460	447HP	CNT200P2FG	\$27,273	1530	16-1/2	96.2	224	2300	03

Note 03 60/50 Hz rated with no derate on HP; 230/460 volt 60 Hz ratings operate on 190/380 volt 50 Hz, 460V 60 Hz ratings operate on 380V 50 Hz; Full 60 & 50 Hz data on Nameplate

† All marks shown within this document are properties of their respective owners.



# Vertical C-Face, Three Phase, Normal Thrust, Totally Enclosed Fan Cooled (TEFC) CORRO-DUTY® NEMA®† Premium Efficient - IE3

## APPLICATIONS:

For pulp & paper, mill & chemical and any other severe duty environments found in the process industries.

## FEATURES:

- Class F Insulation, Class B Rise At Full Load On 60 Hertz Sine Wave Power
- All Cast Iron Construction (Steel Frame On 140 Frame)
- Corrosion Resistant Mill & Chemical Duty Paint
- Stainless Steel Nameplate (with "CE" Mark)
- Shaft Slinger On Both Ends For IP54 Protection
- Regreasable Bearings 140 Frame & Up, Lifting Provisions 180 Frame & Up
- 40°C Ambient, NEMA®† Design B Performance On 60 Hertz Sine Wave Power
- 50 Hz. rated at 190/380V (140-250 Frame) or 380V (280 Frame & Larger)
- 1.15 Service Factor @ 60 Hz.
- Special Balance (< 0.08 In/Sec Vibration)
- Open Bearings 180-447 (Double Shielded Bearings on 140 Frame)
- Steel Drip Cover (Cast Iron on 140 Frame)
- Cast Iron Inner Bearing Caps (180 Frame & Larger)
- Condensation Drain With Threaded Brass Breather Plug
- Oversized Cast Iron Conduit Box - 1 Size Larger Than NEMA®† Standard
- Zinc Plated Hardware
- Discount Symbol: DS-3CE

HP	RPM	Voltage	Frame	Catalog Number	List	NEMA Nom. Eff.	Full Load Amps	Ship Wt. (lbs.)	Notes
1	3600	208-230/460	143TC	C1P1DCR	\$818	80.0	2.9-2.7/1.4	65	03
	1800	208-230/460	145TC	C1P2DCR	\$796	85.5	3.1-3/1.5	65	03
1 1/2	3600	208-230/460	143TC	C32P1DCR	\$891	84.0	4.2-3.9/2	65	03
	1800	208-230/460	145TC	C32P2DCR	\$866	86.5	4.5-4.3/2.1	65	03
2	3600	208-230/460	145TC	C2P1DCR	\$1,013	86.5	5.5-4.9/2.4	70	03
	1800	208-230/460	145TC	C2P2DCR	\$926	86.5	4-3.8/2	70	03
3	3600	208-230/460	182TC	C3P1DCR	\$1,122	87.5	8.4-7.8/3.9	100	03
	1800	208-230/460	182TC	C3P2DCR	\$1,021	89.5	8.4-7.8/3.9	100	03
5	3600	208-230/460	184TC	C5P1DCR	\$1,342	88.5	13.4-12.2/6.1	110	03
	1800	208-230/460	184TC	C5P2DCR	\$1,145	89.5	13.7-12.5/6.3	110	03
7 1/2	3600	208-230/460	213TC	C7P1DCR	\$1,665	91.0	19.9-17.8/8.9	160	03
	1800	208-230/460	213TC	C7P2DCR	\$1,536	91.7	20.1-18.6/9.3	160	03
10	3600	208-230/460	215TC	C10P1DCR	\$1,896	91.0	26.4-23.5/11.8	175	03
	1800	208-230/460	215TC	C10P2DCR	\$1,789	91.7	26.5-23.9/12	175	03
15	3600	208-230/460	254TC	C15P1DCR	\$2,617	91.0	40-35/17.5	300	03
	1800	208-230/460	254TC	C15P2DCR	\$2,396	92.4	40-37/18.4	300	03
20	3600	208-230/460	256TC	C20P1DCR	\$3,141	91.0	53-46/23.1	340	03
	1800	208-230/460	256TC	C20P2DCR	\$2,856	93.0	52-47-23.5	340	03
25	3600	460	284TSC	C25P1FSCR	\$3,913	91.7	29.4	380	03
	1800	460	284TC	C25P2FCR	\$3,510	93.6	29.6	380	03
	1800	460	284TSC	C25P2FSCR	\$3,510	93.6	29.6	380	03
30	3600	460	286TSC	C30P1FSCR	\$4,474	91.7	34	410	03
	1800	460	286TC	C30P2FCR	\$3,983	93.6	34	410	03
	1800	460	286TSC	C30P2FSCR	\$3,983	93.6	34	410	03
40	3600	460	324TSC	C40P1FSCR	\$5,824	92.4	46	600	03
	1800	460	324TC	C40P2FCR	\$5,234	94.1	46	600	03
	1800	460	324TSC	C40P2FSCR	\$5,234	94.1	46	600	03
50	3600	460	326TSC	C50P1FSCR	\$7,235	93.0	56	625	03
	1800	460	326TC	C50P2FCR	\$6,221	94.5	56	625	03
	1800	460	326TSC	C50P2FSCR	\$6,221	94.5	56	625	03
60	3600	460	364TSC	C60P1FSCR	\$9,632	93.6	68	750	03
	1800	460	364TC	C60P2FCR	\$8,912	95.0	69	750	03
	1800	460	364TSC	C60P2FSCR	\$8,912	95.0	69	750	03

Note 03 60/50 Hz rated with no derate on HP; 230/460 volt 60 Hz ratings operate on 190/380 volt 50 Hz, 460V 60 Hz ratings operate on 380V 50 Hz; Full 60 & 50 Hz data on Nameplate

† All marks shown within this document are properties of their respective owners.

Revised — April 2019

# Vertical C-Face, Three Phase, Normal Thrust, Totally Enclosed Fan Cooled (TEFC) CORRO-DUTY® NEMA®† Premium Efficient - IE3 *(continued)*

HP	RPM	Voltage	Frame	Catalog Number	List	NEMA Nom. Eff.	Full Load Amps	Ship Wt. (lbs.)	Notes
75	3600	460	365TSC	C75P1FSCR	\$11,801	93.6	83	910	03
	1800	460	365TC	C75P2FCR	\$11,015	95.4	84	910	03
	1800	460	365TSC	C75P2FSCR	\$11,015	95.4	84	910	03
100	3600	460	405TSC	C100P1FSCR	\$16,042	94.1	112	1300	03
	1800	460	405TC	C100P2FCR	\$14,022	95.4	113	1300	03
	1800	460	405TSC	C100P2FSCR	\$14,022	95.4	113	1300	03
125	3600	460	444TSC	C125P1FSCR	\$19,461	95.0	144	1660	03
	1800	460	444TC	C125P2FCR	\$16,896	95.4	147	1660	03
	1800	460	444TSC	C125P2FSCR	\$16,896	95.4	147	1660	03
150	3600	460	445TSC	C150P1FSCR	\$23,468	95.0	176	1750	03
	1800	460	445TC	C150P2FCR	\$19,664	95.8	171	1750	03
	1800	460	445TSC	C150P2FSCR	\$19,664	95.8	171	1750	03
200	3600	460	447TSC	C200P1FSCR	\$29,321	95.4	220	2100	03
	1800	460	447TC	C200P2FCR	\$23,716	96.2	224	2100	03
	1800	460	447TSC	C200P2FSCR	\$23,716	96.2	224	2100	03

Note 03 60/50 Hz rated with no derate on HP; 230/460 volt 60 Hz ratings operate on 190/380 volt 50 Hz, 460V 60 Hz ratings operate on 380V 50 Hz; Full 60 & 50 Hz data on Nameplate

† All marks shown within this document are properties of their respective owners.



# HOLLOSHAFT® Motors

## Steady Bushing Kits

### FEATURES:

Steady bushings are designed to fit HOLLOSHAFT® motors and will give the mechanical characteristics of a solid shaft motor. Be sure to enter steady bushings with the motor order. Steady bushings will be included with the motor attached to the skid for customer installation in the field. Product listed may not be available from stock.

Frame	Type	Kit Part Number	Bore Size	List Price
182-215	AUS, AUSI, TUS, TUCI	365649	0.750	\$202
		978141	0.875	\$202
		365650	1.000	\$202
254-286	AUS, AUSI, TUS	365651	0.750	\$202
		978142	0.875	\$202
		365657	1.000	\$202
		978143	1.063	\$202
		365659	1.188	\$202
		365662	1.250	\$202
284-286	TUCI	365663	1.000	\$202
		365664	1.188	\$202
		365665	1.250	\$202
		978146	1.500	\$202
324-326	RUS, RUSI, TUS, TUCI	978147	1.000	\$300
		365666	1.188	\$300
		365667	1.250	\$300
		978148	1.313	\$300
		365668	1.438	\$300
		365669	1.500	\$300
364-365	RUS, RUSI	978147	1.000	\$300
		365666	1.188	\$300
		365667	1.250	\$300
		978148	1.313	\$300
		365668	1.438	\$300
		365669	1.500	\$300
364-365	TUS, TUCI	978149	1.000	\$300
		365670	1.188	\$300
		365671	1.250	\$300
		365672	1.438	\$300
		365673	1.500	\$300
		978150	1.563	\$300
		978151	1.625	\$300
		978153	1.688	\$300
		978152	1.750	\$300
404-405	RUS, RUSI	978154	1.188	\$300
		978155	1.250	\$300
		365674	1.438	\$300
		365675	1.500	\$300
		978156	1.563	\$300
		365676	1.688	\$300
		978157	1.813	\$300

Discount Symbol: DS-7VS

† All marks shown within this document are properties of their respective owners.

Revised — April 2019



# HOLLOSHAFT® Motors

## Steady Bushing Kits

### FEATURES:

Steady bushings are designed to fit HOLLOSHAFT® motors and will give the mechanical characteristics of a solid shaft motor. Be sure to enter steady bushings with the motor order. Steady bushings will be included with the motor attached to the skid for customer installation in the field. Product listed may not be available from stock.

Frame	Type	Kit Part Number	Bore Size	List Price
404-405	TUS, TUCI	365677	1.438	\$300
		365678	1.500	\$300
		978158	1.563	\$300
		978159	1.625	\$300
		365679	1.688	\$300
		978160	1.750	\$300
		978161	1.875	\$300
		365680	1.938	\$300
H444-447	RUS, RUSI	978162	1.313	\$300
		365677	1.438	\$300
		365678	1.500	\$300
		365679	1.688	\$300
		978160	1.750	\$300
		365680	1.938	\$300
		978163	2.125	\$300
		365681	2.188	\$300
444-447	TUS, TUCI	365682	2.250	\$300
		2070898	1.188	\$300
		2070899	1.438	\$300
		2070900	1.500	\$300
		2070901	1.563	\$300
		2070902	1.625	\$300
		2070903	1.688	\$300
		2070904	1.750	\$300
449	RUS, RUSI	2070905	1.875	\$300
		2070906	1.938	\$300
		2074162	1.688	\$418
		2087668*	1.750	\$418
		2074161	1.938	\$418
		2087669*	2.125	\$418
		2074160	2.188	\$418
		2087670*	2.375	\$418
449	HUS, HUSI, JUE, JUCEI	2087671*	2.438	\$418
		2087672*	2.500	\$418
		970273	1.688	\$418
		970274	1.938	\$418
		970275	2.125	\$418
		970276	2.188	\$418
		970277	2.375	\$418
		970278	2.438	\$418
5008-5012	RUE, RUEI	970279	2.500	\$418
		492633-169*	1.688	\$418
		492633-194*	1.938	\$418
		492633-213*	2.125	\$418
		492633-219*	2.188	\$418
		492633-225*	2.250	\$418
		492633-238*	2.375	\$418
		492633-244*	2.438	\$418
		492633-250*	2.500	\$418

Discount Symbol: DS-7VS

\* Product listed may not be available from stock.

† All marks shown within this document are properties of their respective owners.



Revised — April 2019

# Modifiable NEMA<sup>®†</sup> Standard Vertical Motors Conversions & Accessories - Introduction & Pricing Guidelines

---

Select the Base List Price from the previous section.

Price Adders for Accessories and Modifications that are not part of the standard product offering can be found in the following sections. Note that not all Accessories and Modifications are available on all product types or frame sizes. Refer to the detailed description for restrictions and guidelines of each Accessory and Modification.

All List Price Adders carry the same Discount Symbol as the Base List Price.

Percentage Adders are percent of the Base List Price, unless otherwise noted.

Some Accessories/Modifications will require a larger than standard Frame Size. All adders are to be made based on the confirmed Frame Size.

Round Total List Price to the nearest dollar.

Note that some adders are Net Adders.

Refer to office for product lead-times.

Refer to Terms and Conditions of Sale on page vi.

All prices are in U.S. Dollars.

Prices and information subject to change without notice.

This catalog covers both NEMA<sup>®†</sup> Standard and TITAN<sup>®</sup> Stock Vertical Motors.

Our extensive custom motor capabilities are shown in PB500.

For Horizontal Motors, refer to the Custom Motor Catalog (PB202) or TITAN<sup>®</sup> Custom Motor Catalog (PB210).

For a wide range of products from stock, refer to the Standard Motor Products Catalog (FL600).



# Vertical Motors Conversions & Accessories Quick Pick Chart

DISCOUNT SYMBOL: SAME AS MOTOR BEING CONVERTED

Description		Frame Size									
		180	210	250	280	320	360	400	444-447	449	5000
Bearings	Extra High Thrust (175%) (#)	-	-	-	-	5%	5%	5%	5%	5%	5%
Coupling	(Change To Alternate)	NC	NC	NC	NC	NC	NC	NC	NC	NC	NC
Conduit Box	Accessory Conduit Box	901	901	901	901	901	901	901	901	901	901
	Rotate Conduit Box	235	235	235	235	235	235	235	235	235	235
	Cast Iron Conduit Box	-	-	-	-	293	469	587	704	-	-
	Size 2 Cast Iron Box	-	-	-	-	-	-	1408	1408	-	-
	Size 3 Cast Iron Box	-	-	-	-	-	-	3477	3477	3477	3477
Division 2 Self Certified & Division 2 CSA Certified (Eng. Approval Req'd)		-	-	-	-	-	-	-	-	-	-
	Class I, Grps. A/B/C/D T1-T3 T-Codes On Main N/P @ 1.0 SF	NC	NC	NC	NC	NC	NC	NC	NC	NC	-
	Class I, T-Code T1-T3C On Sep. Div. 2 Plate (Self Certified)	100	100	100	100	100	100	100	100	100	-
	Class I, T-Code T1-T3C On Sep. Div. 2 Plate (CSA)	100	100	100	100	100	100	100	100	100	-
Drains	T-Type Breather/Drain	70	70	94	94	94	117	117	117	-	-
Export Boxing	(Net Adder)	(@)	(@)	(@)	(@)	(@)	(@)	(@)	(@)	(@)	(@)
Flanges	(Change Bracket To Alternate "BD")	NC	NC	NC	NC	NC	NC	NC	NC	NC	NC
Ground Lug	In Conduit Box	108	108	108	108	108	108	108	108	108	108
Leads	(Tie Back Leads)	399	587	587	892	892	892	892	892	-	-
Nameplates	Additional Duplicate Nameplate	235	235	235	235	235	235	235	235	235	235
	Additional Stamping On Main Nameplate	235	235	235	235	235	235	235	235	235	235
	Shipping Tag (#6 Paper Tag)	NC	NC	NC	NC	NC	NC	NC	NC	NC	NC
	Special I.D. Plate†	235	235	235	235	235	235	235	235	235	235
	Re-Nameplate (Re-Rate)	235	235	235	235	235	235	235	235	235	235
	Firepump Label	5%	5%	5%	5%	5%	5%	5%	5%	5%	5%
Non-Reverse Ratchet		-	-	-	-	-	-	-	-	-	-
	Bolted Coupling - Add or Remove	NC	NC	NC	NC	NC	NC	NC	NC	NC	NC
	Clockwise Non-Reverse Ratchet	-	-	-	-	469	469	469	469	1408	1408
Prints & Data (Submittals) (NET ADDERS)		-	-	-	-	-	-	-	-	-	-
	Standard Submittals	NC	NC	NC	NC	NC	NC	NC	NC	NC	NC
	Speed Vs. Torque & Amps Curve (Standard 100% Voltage)	NC	NC	NC	NC	NC	NC	NC	NC	NC	NC
	Speed Vs. Torque & Amps Curve (Non-Standard, Multiple Voltages)	60	60	60	60	60	60	60	60	60	60
	Speed Vs. Torque & Amps Curve (Metric)	170	170	170	170	170	170	170	170	170	170
	Safe Stall Time Curve	170	170	170	170	170	170	170	170	170	170
	Acceleration Time Vs. Amps Curve	170	170	170	170	170	170	170	170	170	170
	Performance Curve (Standard)	NC	NC	NC	NC	NC	NC	NC	NC	NC	NC
	Performance Curve (Non-Standard)	170	170	170	170	170	170	170	170	170	170
	Performance Curve (Metric Units)	280	280	280	280	280	280	280	280	280	280
	Shaft Stiffness	170	170	170	170	170	170	170	170	170	170
	Torsional Analysis	170	170	170	170	170	170	170	170	170	170
	Sound Power In Watts	60	60	60	60	60	60	60	60	60	60
	Sound Pressure In dB @ 3 Feet	30	30	30	30	30	30	30	30	30	30
	Sound Data Vs. Center Band	60	60	60	60	60	60	60	60	60	60
	Customer Data Sheet	60	60	60	60	60	60	60	60	60	60
	Equivalent Circuit Data	60	60	60	60	60	60	60	60	60	60

(N) Net Adder  
 (NC) No Charge if specified at time of Motor order.  
 (+) Refer to Conversion Pricing Section for description.

(@) Refer to Optional Export Packing Charges Section.  
 (#) Available only on Premium Efficient HOLLOSHAFT® WPI

† All marks shown within this document are properties of their respective owners.





# Vertical Motors

## Conversions & Accessories Quick Pick Chart

DISCOUNT SYMBOL: SAME AS MOTOR BEING CONVERTED

Description		Frame Size									
		180	210	250	280	320	360	400	444-447	449	5000
Prints & Data	UL <sup>®†</sup> Certificate	4500	4500	4500	4500	4500	4500	4500	4500	4500	4500
	Certificate Of Conformance	60	60	60	60	60	60	60	60	60	60
	Shaft Print	60	60	60	60	60	60	60	60	60	60
	Shaft Print With Material Strength	220	220	220	220	220	220	220	220	220	220
	Rotor Detail Print	280	280	280	280	280	280	280	280	280	280
	Rotor Detail & Shaft Print	330	330	330	330	330	330	330	330	330	330
	Current Pulsation Analysis	220	220	220	220	220	220	220	220	220	220
	Bearing Life Calculation	155	155	155	155	155	155	155	155	155	155
	Space Heater (Double Adder For Hazardous Location Motors)	477	477	512	512	596	643	643	643	1326	1326
Steady Bushing Kit (Attached To Motor Eyebolt)	202	202	202	202	300	300	300	300	418	418	
Tests	Short Commercial Test, Un-Witnessed	662	662	662	662	662	662	662	662	662	662
	Complete Initial Test, Un-Witnessed	3580	3580	5317	5317	5317	5317	5317	5317	5317	5317
Thermal Protection, Bearings (Upper Bracket) (#)		-	-	-	-	-	-	-	-	-	-
	RTD's, 10 or 120 Ohm	-	-	-	-	1338	1338	1338	1338	1338	1338
	RTD's, 100 Ohm	-	-	-	-	1338	1338	1338	1338	1338	1338
Thermal Protection, Windings		-	-	-	-	-	-	-	-	-	-
	Thermostats (Double Adder For Haz. Loc. Motors)	265	265	265	265	418	519	519	519	519	519
	Thermistors	472	472	472	472	669	669	876	876	876	876
	THERMA SENTRY <sup>®</sup>	587	587	587	587	587	587	587	1150	1150	1150
	Thermocouples	3434	3434	3434	3434	3434	3434	3434	3434	3434	3434
Vibration Detector (#)	Robertshaw <sup>®†</sup> Model 366	-	-	-	-	1878	1878	1878	1878	-	-

(N) Net Adder  
 (NC) No Charge if specified at time of Motor order.  
 (+) Refer to Conversion Pricing Section for description.

(@) Refer to Optional Export Packing Charges Section.  
 (#) Available only on Premium Efficient HOLLOSHAFT<sup>®</sup> WPI

† All marks shown within this document are properties of their respective owners.

Revised — April 2019



# Vertical Motors Conversion & Accessories

## Description & Adders

DISCOUNT SYMBOL: SAME AS MOTOR BEING CONVERTED

### Bearings

#### Extra High Thrust (175%)

Frame:	180	210	250	280	320	360	400	444-447	449	5000
Adder:	-	-	-	-	5%	5%	5%	5%	5%	5%

• Available only on Premium Efficient Vertical HOLLOSHAFT® WPI (Type RUS, RUSI, RUE & RUEI).

### Coupling

#### Change To Alternate Coupling Size

Frame:	180	210	250	280	320	360	400	444-447	449	5000
Adder:	NC	NC	NC	NC	NC	NC	NC	NC	NC	NC

• Standard drive coupling can be changed to an alternate size at no charge, if specified at time of motor order.

### Conduit Boxes

#### Accessory Conduit Box

Frame:	180	210	250	280	320	360	400	444-447	449	5000
Adder:	901	901	901	901	901	901	901	901	901	901

• A conduit can be added to the main motor conduit box for routing of accessory leads. Available on WPI and TEFC ratings.

#### Rotate Conduit Box

Frame:	180	210	250	280	320	360	400	444-447	449	5000
Adder:	235	235	235	235	235	235	235	235	235	235

- Standard conduit box has lead opening facing down. This conversion includes rotating the conduit box, so the lead opening is facing the desired direction.
- Specify direction of lead opening: Facing up; Facing left (when facing the conduit box); Facing right (when facing the conduit box)
- Available at no charge if specified at time of order placement.

#### Cast Iron Conduit Box

Frame:	180	210	250	280	320	360	400	444-447	449	5000
Adder:	-	-	-	-	293	469	587	704	-	-

- Replacement of steel conduit box with cast iron version.
- Available on HOLLOSHAFT®, 320 frame and larger.

#### Size 2 Cast Iron Box (1-3.5 NPT Openings)

Frame:	180	210	250	280	320	360	400	444-447	449	5000
Adder:	-	-	-	-	-	-	1408	1408	-	-

#### Size 3 Cast Iron Box (2-3.5 NPT Openings)

Frame:	180	210	250	280	320	360	400	444-447	449	5000
Adder:	-	-	-	-	-	-	3477	3477	3477	3477

### Division 2 Self Certified & Division 2 CSA®† Certified

#### (+) Refer To The Charts Below For Pricing

Frame:	180	210	250	280	320	360	400	444-447	449	5000
Adder:	(+)	(+)	(+)	(+)	(+)	(+)	(+)	(+)	-	-

The following restrictions apply:

- Contact an NMC Technical Representative to confirm availability.
- Inverter suitability limited to T1-T3 T-codes.
- Zone 2 markings available on separate Division 2 nameplate options.
- Only Available on TEFC TUS, JUE, TVCS & TCEF Motor Types models.
- Class II not available.
- Temp codes T-4 to T-6 not available.

† All marks shown within this document are properties of their respective owners.



# Vertical Motors Conversion & Accessories

## Description & Adders

DISCOUNT SYMBOL: SAME AS MOTOR BEING CONVERTED

### Division 2 Self Certified & Division 2 CSA<sup>®†</sup> Certified (continued)

Class I, Grps. A/B/C/D T1-T3 T-Codes On Main N/P @ 1.0 SF (On TUS, JUE, TVCS &amp; TCEF Models – Standard Rating ONLY)

Frame:	180	210	250	280	320	360	400	444-447	449	5000
Adder:	NC	NC	NC	NC	NC	NC	NC	NC	NC	-

- Contact an NMC Technical Representative to confirm availability.

#### Class I, T-Code T1-T3C on Separate Division 2 Plate (Self Certified)

Frame:	180	210	250	280	320	360	400	444-447	449	5000
Adder:	100	100	100	100	100	100	100	100	100	-

- Contact an NMC Technical Representative to confirm availability.

#### Class I, T-Code T1-T3C On Separate CSA Division 2 Plate (CSA)

Frame:	180	210	250	280	320	360	400	444-447	449	5000
Adder:	100	100	100	100	100	100	100	100	100	-

- Contact an NMC Technical Representative to confirm availability.

## Drains (Breather/Drains)

### T-Type Breather/Drain

Frame:	180	210	250	280	320	360	400	444-447	449	5000
Adder:	70	70	94	94	94	117	117	117	-	-

- Install T-Type breather/drains in place of standard drains.
- Available on 180-447 frame cast iron enclosed motors.

## Export Boxing

Frame:	180	210	250	280	320	360	400	444-447	449	5000
Adder:	(@)	(@)	(@)	(@)	(@)	(@)	(@)	(@)	(@)	(@)

- Product is boxed, packaged or crated as required for under deck exporting.
- (@) Refer to Optional Export Packing Charges Section.

## Flanges

### Change P-Base Bracket to Alternate "BD" Dimension

Frame:	180	210	250	280	320	360	400	444-447	449	5000
Adder:	NC	NC	NC	NC	NC	NC	NC	NC	NC	NC

- Replace standard "P" base bracket with one of different "BD" dimension.
- Available at no charge if specified at time of order placement.

## Ground Lug

### In Conduit Box

Frame:	180	210	250	280	320	360	400	444-447	449	5000
Adder:	108	108	108	108	108	108	108	108	108	108

- Addition of ground lug in main motor conduit box.



# Vertical Motors Conversion & Accessories

## Description & Adders

DISCOUNT SYMBOL: SAME AS MOTOR BEING CONVERTED

### Leads

#### Tie Back Leads

Frame:	180	210	250	280	320	360	400	444-447	449	5000
Adder:	399	587	587	892	892	892	892	892	892	-

- Reconnect dual voltage 9-lead or 12-lead motors to 3-lead single voltage. Tie back and connect leads inside frame for single voltage 3-lead conduit box connections.
- Specify desired voltage when ordering.

### Nameplates

#### Additional Duplicate Nameplate

Frame:	180	210	250	280	320	360	400	444-447	449	5000
Adder:	235	235	235	235	235	235	235	235	235	235

- An additional duplicate nameplate for mounting on customer equipment. These additional nameplates cannot be supplied with CSA<sup>®</sup> or UL<sup>®</sup> logos.

#### Additional Stamping On Main Nameplate

Frame:	180	210	250	280	320	360	400	444-447	449	5000
Adder:	235	235	235	235	235	235	235	235	235	235

- The main motor nameplate can be stamped with limited customer tagging information (20 characters max).

#### Shipping Tag (#6 Paper Tag)

Frame:	180	210	250	280	320	360	400	444-447	449	5000
Adder:	NC	NC	NC	NC	NC	NC	NC	NC	NC	NC

- A #6 paper shipping tag, with customer tagging information, can be supplied at no charge when specified at time of motor order.

#### Special I.D. Plate

Frame:	180	210	250	280	320	360	400	444-447	449	5000
Adder:	235	235	235	235	235	235	235	235	235	235

- Special identification plates can be mounted on the motor with limited customer specified tagging information (100 characters max).

#### Re-Nameplate (Re-Rate)

Frame:	180	210	250	280	320	360	400	444-447	449	5000
Adder:	235	235	235	235	235	235	235	235	235	235

- Motors can be re-nameplated (after approval) for alternate ratings. Changes in horsepower, altitude, ambient, voltage, frequency, etc.
- Contact an NMC Technical Representative for approval prior to quoting.

#### Fire Pump Label

Frame:	180	210	250	280	320	360	400	444-447	449	5000
Adder:	5%	5%	5%	5%	5%	5%	5%	5%	5%	5%

- Percentage adders are percent of base list price. UL<sup>®</sup> Listed (File EX5189) fire pump motors are designed per UL-1004-5<sup>®</sup> and meet the NFPA-20<sup>®</sup> "Standard for the Installation of Centrifugal Fire Pump Spec". This conversion is to add the fire pump label.
- Contact your NMC Technical Representative with exact rating to confirm that it meets the fire pump requirements.

### Non-Reverse Ratchet

#### Bolted Coupling - Add or Remove

Frame:	180	210	250	280	320	360	400	444-447	449	5000
Adder:	NC	NC	NC	NC	NC	NC	NC	NC	NC	NC

- Remove non-reverse ratchet (NRR) and convert motor to self-release coupling (SRC) or bolted coupling.
- Available at no charge if specified at time of order placement.

† All marks shown within this document are properties of their respective owners.



Revised — April 2019

# Vertical Motors Conversion & Accessories

## Description & Adders

DISCOUNT SYMBOL: SAME AS MOTOR BEING CONVERTED

### Non-Reverse Ratchet *(continued)*

#### Clockwise Non-Reverse Ratchet

Frame:	180	210	250	280	320	360	400	444-447	449	5000
Adder:	-	-	-	-	5%	5%	5%	5%	5%	5%

- Remove non-reverse ratchet (NRR) and (Counter Clockwise Rotation) and replace with a Clockwise Rotation (when looking down on the motor) non-reverse ratchet.
- Available only on Premium Efficient Vertical HOLLOSHAFT® WPI (Type RUS & RUSI).

### Prints & Data (Submittals)

#### (NET ADDERS)

Frame:	56	140	180	210	250	280	320	360	400	444-447	449(DP)	449(TE)	5000	5800
Adder:	(QP)	(QP)	(QP)	(QP)	(QP)	(QP)	(QP)	(QP)	(QP)	(QP)	(QP)	(QP)	(QP)	(QP)

- Submittals adders are NET ADDERS. (QP) refer to Vertical motors quick pick chart.
- The following submittals are considered standard submittals, and are available at no charge if requested at time of motor order:
  - Certified Dimension Print
  - Performance Data
  - Nameplate Data
  - Instruction Manual
  - Wiring Diagram
  - Part List
  - Recommended Spare Parts
  - Bearing Life Calculation
  - Conduit Box Details
  - Paint Specification
  - Rotor Air Gap (Calculated)
  - Rotor Inertia
  - Cut Sheets For Accessories

### Space Heaters

#### (Double Adder for Explosionproof Motors)

Frame:	180	210	250	280	320	360	400	444-447	449	5000
Adder:	477	477	512	512	596	643	643	643	1326	1326

- Space heaters are installed to prevent moisture condensation in the motor during times the motor is not running. NMC uses silicon rubber strip-type heaters manufactured by sandwiching a resistance wire network between two pieces of high-temperature silicon rubber and bonding the pieces together. Heaters are sized to provide approximately 10°C temperature rise above the ambient temperature.
- Heaters are placed on the end turns of the motor winding. Heaters are of the low-density type, which yields low surface temperature and long life. Heaters are single phase, rated 60 or 50 Hertz.
- Space Heaters are available in the following voltages:
  - 115, 230, 460 & 575 Volt
  - 230 Volt operated at 115 Volt

### Steady Bushing Kit

#### (Attached To Motor Eyebolt)

Frame:	180	210	250	280	320	360	400	444-447	449	5000
Adder:	202	202	202	202	300	300	300	300	418	418

- Steady bushing comes as a field-installable kit, and is shipped attached to the motor eyebolt.



# Vertical Motors Conversion & Accessories

## Description & Adders

DISCOUNT SYMBOL: SAME AS MOTOR BEING CONVERTED

### Tests

#### Short Commercial Test, Un-Witnessed

Frame:	180	210	250	280	320	360	400	444-447	449	5000
Adder:	662	662	662	662	662	662	662	662	662	662

• A Short Commercial Test, per NEMA® MG-1 Part 12, consists of no-load current, locked rotor current (performed at reduced voltage, typically 25-50%), winding resistance, high potential, and bearing inspection. A test report is provided to the customer.

#### Complete Initial Test, Un-Witnessed

Frame:	180	210	250	280	320	360	400	444-447	449	5000
Adder:	3580	3580	5317	5317	5317	5317	5317	5317	5317	5317

• A Complete Initial Test consists of full load heat run, percent slip, no load current, full load current, locked rotor current, locked rotor torque, breakdown torque (calculated), efficiency & power factor at 100%, 75% & 50% full load, winding resistance, high potential, and bearing inspection. This test is performed in accordance with IEEE 112 Method B. A test report is provided to the customer. Motor will be shipped to an NMC facility with a calibrated lab for testing and will require additional lead-time.

• Contact an NMC Technical Representative for availability and lead-time.

### Thermal Protection, Bearings (Upper Bracket)

#### Resistance Temperature Detectors (RTD's), 10 or 120 Ohm

Frame:	180	210	250	280	320	360	400	444-447	449	5000
Adder:	-	-	-	-	1338	1338	1338	1338	1338	1338

- Resistance Temperature Detector (RTD): Precision, wire-wound resistors with a known temperature-resistance characteristic. NMC does not furnish the monitor.
- Available only on Vertical HOLLOSHAFT® WPI (Type RUS, RUSI, RUE & RUEI). Available on Upper Bracket Only.
- The following options are available:
  - TB40 10 Ohm, 3 lead
  - TB41 120 Ohm, 2 lead
  - TB42 100 Ohm, 3 lead

#### Resistance Temperature Detectors (RTD's), 100 Ohm

Frame:	180	210	250	280	320	360	400	444-447	449	5000
Adder:	-	-	-	-	1338	1338	1338	1338	1338	1338

- Resistance Temperature Detector (RTD): Precision, wire-wound resistors with a known temperature-resistance characteristic. NMC does not furnish the monitor.
- Available only on Premium Efficient Vertical HOLLOSHAFT® WPI (Type RUS, RUSI, RUE & RUEI). Available on Upper Bracket Only.
- The following option is available:
  - TB42 100 Ohm, 3 Lead

### Thermal Protection, Windings

#### Thermostats (Double Adder for Hazardous Location Motors)

Frame:	180	210	250	280	320	360	400	444-447	449	5000
Adder:	265	265	265	265	418	519	519	519	519	519

- Thermostats: Snap action, bi-metallic, temperature actuated switches installed on the end-turns of the motor winding. Their purpose is to activate a warning device or shut down the motor upon excessive winding temperatures. Standard arrangement is addition of 2 or 3 thermostats to the winding end-turns, connected in series with the leads brought out to the main motor conduit box.
- The following options are available:
  - TW01 Thermostats, normally closed
  - TW02 Thermostats, normally open
  - TW06 Thermostats, normally closed, hermetically sealed



# Vertical Motors Conversion & Accessories

## Description & Adders

DISCOUNT SYMBOL: SAME AS MOTOR BEING CONVERTED

### Thermal Protection, Windings *(continued)*

#### Thermistors

Frame:	180	210	250	280	320	360	400	444-447	449	5000
Adder:	472	472	472	472	669	669	876	876	876	876

- Thermistors: Non-linear resistance temperature detector made from semi-conductor material. Standard arrangement is Q-3 positive temperature coefficient (PTC) type on winding end-turns with leads brought out to the main motor conduit box.
- The following options are available:
  - TW10 Thermistors (PTC Type), Texas Instruments®, 6 leads out

#### THERMA SENTRY®

Frame:	180	210	250	280	320	360	400	444-447	449	5000
Adder:	587	587	587	587	587	587	587	1150	1150	1150

- THERMA SENTRY®: Complete protection system consisting of three thermistors and a solid-state control module (shipped loose for customer mounting). It will protect the motor for locked rotor, starting overload, running overload, abnormally high ambient temperatures, voltage unbalance, high or low voltages, ventilation failure, and single phasing.
- The following options are available:
  - TW20 THERMA SENTRY®, 115/230V, SMSE, normally closed contact (SMSE = separately mounted, separately excited control module)

#### Thermocouples

Frame:	180	210	250	280	320	360	400	444-447	449	5000
Adder:	3434	3434	3434	3434	3434	3434	3434	3434	3434	3434

- Thermocouples: A pair of dissimilar conductors so joined at one point that an electromotive force is developed by the thermoelectric effects. Standard arrangement is addition of thermocouples to the winding end-turns with leads brought out to the main motor conduit box.
- The following options are available:
  - TW32 Thermocouples, Iron Constantan (Type J)

### Vibration Detector

#### Robertshaw†, Model 366

Frame:	180	210	250	280	320	360	400	444-447	449	5000
Adder:	-	-	-	-	1878	1878	1878	1878	-	-

- Available only on Premium Efficient Vertical HOLLOSHAFT® WPI (Type RUS & RUSI).



# Modifiable NEMA<sup>®†</sup> Standard Vertical Motors

## Quick Engineering Facts

VERTICAL  
MOTORS

STEADY BUSHING  
KITS

CONVERSION  
CENTER

QUICK ENGINEERING  
FACTS

FORMULAS

LONG TERM STORAGE  
INFORMATION

OPERATING  
CHARACTERISTICS

DIMENSION  
PRINT INDEX

DRIVE COUPLING  
PART NUMBERS

DIMENSION  
PRINTS

### WPI

FRAME SIZE	STANDARD BASE DIAMETER	ALTERNATE BASE DIAMETER	MAX 'BX' COUPLING BORE	CD'DIM. COUPLING HEIGHT	TYPICAL SHIPPING WT. (LBS.)
213TP	10	-	1.001	17.56	210
215TP	10	-	1.001	17.56	220
254TP	10	12/16.5	1.251	23.38	265
256TP	10	12/16.5	1.251	23.38*	300
284TP	12	10/16.5	1.251	24.75	305
286TP	12	10/16.5	1.251	24.75	325
324TP	16.5	12	1.501	28.22	635
326TP	16.5	12	1.501	28.22	675
364TP	16.5	12	1.501	31.16	730
365TP	16.5	12	1.501	31.16	800
404TP	16.5	20	1.813	36.94	1110
405TP	16.5	20	1.813	36.94	1220
H444TP	16.5	20	2.251	44.78	1500
H445TP	16.5	20	2.251	44.78	1600
447TPA	20	16.5/24.5	2.251	49.78	2200
449TPH	20	24.5/30.5	2.501	49.81	2800
5008PH	20	24.5/30.5	2.501	57.06	4200
5012P	24.5	20/30.5	2.751	72.30	5450

\* Premium efficiency has 24.75" CD on this frame

### TEFC

FRAME SIZE	STANDARD BASE DIAMETER	ALTERNATE BASE DIAMETER	MAX 'BX' COUPLING BORE	CD-COUPLING HEIGHT TEFC	CD-COUPLING HEIGHT C-DUTY	TYPICAL SHIPPING WT. (LBS.) TEFC	TYPICAL SHIPPING WT. (LBS.) C-DUTY
182TP	10	-	1.001	17.56	17.5	170	180
184TP	10	-	1.001	17.56	17.5	170	180
213TP	10	-	1.001	-	17.5	-	220
215TP	10	-	1.001	-	17.5	-	230
H213TP	10	-	1.001	18.81	-	210	-
H215TP	10	-	1.001	18.81	-	220	-
254TP	10	12	1.251	22.94	22.94	265	395
256TP	10	12	1.251	22.94	22.94	300	405
284TP	10	12/16.5	1.251/1.501**	26.56	26.56	320	500
286TP	10	12/16.5	1.251/1.501**	26.56	26.56	330	520
324TP	16.5	12	1.501	28.50	28.50	665	740
326TP	16.5	12	1.501	28.50	28.50	690	750
364TP	16.5	-	1.751	30	30	900	925
365TP	16.5	-	1.751	30	30	925	940
405TP	16.5	20	1.938	39.94	39.94	1500	1600
444TP	16.5	20	1.938	42.50	42.50	1800	1900
447TP	16.5	20	1.938	46	46	2300	2300
449TP	24.5	20	2.501	56.88	56.88	3800	3900

\*\* BX has 1.501 max BX bore on CORRO-DUTY (TUCI)

† All marks shown within this document are properties of their respective owners.

Revised — April 2019





## Formulas

kW <sub>out</sub> = HP <sub>out</sub> x 0.746	
Torque in lb-ft	$\frac{\text{HP} \times 5252}{\text{RPM}}$
Motor synchronous speed in RPM	$\frac{120 \times \text{Hz}}{\text{number of poles}}$
Three-phase full-load amp	$\frac{\text{HP} \times 0.746}{1.73 \times \text{kV} \times \text{efficiency}^* \times \text{power factor}^*}$
Rated motor kVA	$\frac{\text{HP} \times 0.746}{\text{efficiency}^* \times \text{power factor}^*}$
kW loss	$\frac{\text{HP} (0.746) (1.0 \text{ efficiency}^*)}{\text{efficiency}^*}$
Wk <sup>2</sup> referred to motor shaft speed	$\left[ \frac{\text{driven machine Wk}^2 (\text{driven machine rpm})^2}{\text{motor RPM}} \right] + \text{gear Wk}^2 \text{ at motor speed}$
Accelerating time	$\frac{0.462 (\text{Wk}^2 \text{ of motor and load}) \text{ RPM}^2}{\text{motor rated kW} \times 106 \times \text{per unit effective accelerating torque}}$
kVA in-rush	percent in-rush x rated kVA
Approximate voltage drop (%)	$\frac{\text{motor kVA in-rush}}{\text{transformer kVA}} \times \text{transformer impedance (normally 5\% to 7\%)}$
Stored kinetic energy in kW-sec	2.31 x (total Wk <sup>2</sup> ) x RPM <sup>2</sup> x 10 <sup>7</sup>
Inertia constant (H) in seconds	$\frac{\text{stored kinetic energy in kW-seconds}}{\text{HP} (0.746)}$
Conversion factors:	CV = (metric HP) = 735.5 watts = 75 kg-m/sec Wk <sup>2</sup> (lb-ft) = 5.93 x GD <sup>2</sup> (kg-m <sup>2</sup> )
Ventilating-air requirements:	100-125 cfm of 40°C air at 1/2-in. water pressure for each kW of loss
Degrees C	$(\text{Degrees F} - 32) \times \frac{5}{9}$
Degrees F	$\left[ (\text{Degrees C}) \times \frac{9}{5} \right] + 32$

\*Efficiency and power factor stated as decimal value rather than percentage.

## Long Term Storage Information

### LONG-TERM STORAGE FOR MOTORS WITH GREASE AND OIL-LUBRICATED BEARINGS

**NOTE: DO NOT WRAP OR COVER MOTOR WITH PLASTIC!**

#### 1. When to put a motor in storage

If a motor is not put into immediate service (one month or less), or if it is taken out of service for a prolonged period, special storage precautions should be taken to prevent environmental damage. The following schedule is recommended as a guide to determine storage needs.

- Out of service or in storage less than one month -- no special precautions except that space heaters, if supplied, must be energized at any time the motor is not running.
- Out of service or in storage for more than one month but less than six months -- store per items 2A, B, C, D, E, F2 and G, items 3A, B and C, and item 4.
- Out of service or in storage for six months or more - all recommendations.

#### 2. Storage preparation

- Where possible, motors should be stored indoors in a clean, dry area.
- When indoor storage is not possible, the motors must be covered with a tarpaulin. This cover should extend to the ground; however, it should not tightly wrap the motor. This will allow the captive air space to breathe, minimizing formation of condensation. Care must also be taken to protect the motor from flooding or from harmful chemical vapors.
- Whether indoors or out, the area of storage should be free from ambient vibration. Excessive vibration can cause bearing damage. A unit which must be stored in areas with high ambient vibration, such as from heavy construction equipment or other sources, must have the shaft locked to prevent any movement.
- Precautions should be taken to prevent rodents, snakes, birds, or other small animals from nesting inside the motors. In areas where they are prevalent, precautions must be taken to prevent insects, such as mud dauber asps, from gaining access to the interior of the motor.
- Inspect the rust preventative coating on all external machined surfaces, including shaft extensions. If necessary, recoat the surfaces with a rust preventative material, such as Rust Veto No. 342 (manufactured by E.F. Houghton Co.) or an equivalent. The condition of the coating should be checked periodically and surfaces recoated as needed.
- Bearings:
  - 1) Grease lubricated cavities must be completely filled with lubricant during storage. Remove the drain plug and fill cavity with grease until grease begins to purge from drain opening. Refer to the section on "LUBRICATION" in the Installation/Maintenance Instruction and/or review motor's lubrication nameplate for correct lubricant.

**CAUTION:**

**DO NOT ATTEMPT TO GREASE BEARINGS WITH DRAIN CLOSED  
OR WHEN UNIT IS IN OPERATION.**

- 2) Oil lubricated motors are shipped without oil and must be filled to the maximum capacity as indicated on the oil chamber sight gauge window immediately upon receipt. Fill reservoir to maximum level with a properly selected oil containing rust and corrosion inhibitors such as Texaco Regal Marine #77, Mobil Vaprotec Light, or an equivalent.

*NOTE: Motor must not be moved with oil in reservoir. Drain oil before moving to prevent sloshing and possible damage, then refill when at new location.*

## Long Term Storage Information

### LONG-TERM STORAGE FOR MOTORS WITH GREASE AND OIL-LUBRICATED BEARINGS

(continued)

- To prevent moisture accumulation, some form of heating must be utilized to prevent condensation. This heating should maintain the winding temperature at a minimum of 5°C above ambient. If space heaters are supplied, they should be energized. If none are available, single phase or “trickle” heating may be utilized by energizing one phase of the motor’s winding with a low voltage. Request the required voltage and transformer capacity from Nidec Motor Corporation. A third option is to use an auxiliary heat source and keep the winding warm by either convection or blowing warm air into the motor.

#### 3. Periodic Maintenance.

- Oil should be inspected monthly for evidence of moisture or oxidation. The oil must be replaced whenever contamination is noted or every twelve months; whichever occurs first.
- Grease lubricated bearings must be inspected once a month for moisture and oxidation by purging a small quantity of grease through the drain. If any contamination is present, the grease must be completely removed and replaced.
- All motors must have the shaft rotated once a month to insure the maintenance of a coating lubricant film on the bearing races and journals.
- Insulation History:  
The only accurate way to evaluate the condition of the winding insulation is to maintain a history of the insulation readings. Over a period of months or years these readings will tend to indicate a trend. If a downward trend develops, or if the resistance drops too low, thoroughly clean and dry the windings, retreating if necessary, by an authorized electrical apparatus service shop develops, or if the resistance drops too low, thoroughly clean and dry the windings, retreating if necessary, by an authorized electrical apparatus service shop.

The recommended insulation resistance tests are as follows:

- Using a megohm meter, with winding at ambient temperature, apply DC voltage (noted below) for sixty seconds and take reading.

Rated Motor Voltage
600 and less 500 VDC
601 to 1000 (incl.)
1001 and up

Recommended DC Test Voltage
500 to 1000 VDC
500 to 2500 VDC
(2500 VDC optimum)

- For comparison, the reading should be corrected to a 40°C base temperature. This may be done by utilizing the following:

$$R_{40C} = K_t \times R_t$$

Where  $R_{40C}$  = insulation resistance (in megohms) corrected to 40°C

$R_t$  = measured insulation resistance (in megohms)

$K_t$  = temperature coefficient (from Graph 1)

GRAPH 1

WINDING  
TEMPERATURE (°C)

(Adapted from IEEE 43)

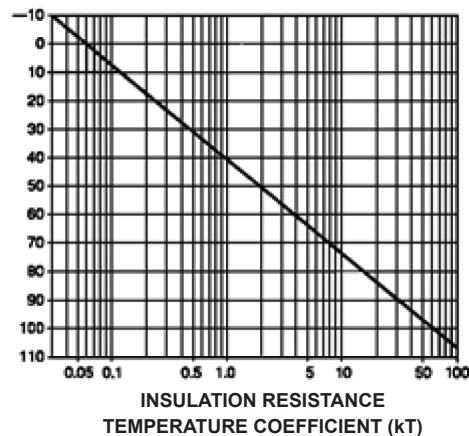

## Long Term Storage Information

### LONG-TERM STORAGE FOR MOTORS WITH GREASE AND OIL-LUBRICATED BEARINGS

(continued)

(3) Insulation resistance readings must not drop below the value indicated by the following formula:

$$R_m = K_v + 1$$

$R_m$  = minimum insulation (in megohms) at 40°C

$K_v$  = rated motor voltage in kilovolts Recommended DC Test Voltage

(4) Dielectric absorption ratio:

In addition to the individual test reading, a dielectric absorption ratio may be required. The dielectric absorption ratio is obtained by taking megohm meter readings at a one-minute and ten-minute interval, or when hand powered megohm meters are used, at a thirty-second and sixty-second interval. The voltage should be the same as outlined in item 3D, part 1.

The ratio is obtained by dividing the second reading by the first reading and is based on a good insulation system increasing its resistance when subjected to a test voltage for a period of time. The ratios are as follows:

10 Minute: 1 Minute	60 Second: 30 Second
Dangerous = Less than 1.0	Poor = Less than 1.1
Poor = 1.0 to 1.4	Questionable = 1.1 to 1.24
Questionable = 1.5 to 1.9	Fair = 1.25 to 1.3
Fair = 2.0 to 2.9	Good = 3.0 to 4.0
Good = 1.4 to 1.6	Excellent = Over 1.6
Excellent = Over 4.0	

If a lower insulation resistance reading is obtained in either the individual test or dielectric absorption ratio test, thoroughly clean and dry the windings. Recheck insulation resistance and dielectric absorption ratio.

*NOTE: Slightly lower dielectric absorption ratios may be acceptable when high initial insulation resistance readings are obtained (1000 + megohms). Refer any questions to Product Service department.*

For additional information on insulation testing, refer to IEEE Transaction No. 43.

#### 4. Start-up preparations after storage

- Motor should be thoroughly inspected and cleaned to restore to an "As Shipped" condition.
- Motors which have been subjected to vibration must be disassembled and each bearing inspected for damage.
- Oil and/or grease must be completely changed using lubricants and methods recommended on the motor's lubrication plate, or in the section titled "LUBRICATION" in the Installation/Maintenance manual.
- The winding must be tested to obtain insulation resistance and dielectric absorption ratio as described in section III, item 3.
- If storage has exceeded one year, the Nidec Motor Corporation Quality Assurance Department must be contacted prior to equipment startup.

# Operating Characteristics - Vertical HOLLOWSHAFT® Motors

## High Thrust - "P" Base, Three Phase, Weather Protected Type (WPI), Premium Efficient, SINEWAVE OPTIMIZED®

CATALOG NUMBER	HP	RPM		% EFFICIENCY				% POWER FACTOR			CURRENT (AMPS) 460 VOLTS		TORQUE AT FULL VOLTAGE (FT. LBS.)			NEMA CODE
		NO LOAD	FULL LOAD	NEMA Nom. Eff.	FULL LOAD	3/4 LOAD	1/2 LOAD	FULL LOAD	3/4 LOAD	1/2 LOAD	FULL LOAD	LOCKED STARTING	FULL LOAD TORQUE @	LOCKED (STARTING)	PULLOUT BREAK- DOWN	
													FULL LOAD SPEED			
HO7P2BLE	7-1/2	1800	1765	91.7	91.7	92.3	91.7	85.4	82.6	75.6	9	59	22.3	226	291	H
HO7P3BLF		1200	1180	90.2	90.2	90.8	89.7	78.1	72.3	61	10	57.7	33.3	191	274	G
HO10P2BLE	10	1800	1760	91.7	91.7	92.5	92.2	85.6	82.6	75.5	11.9	79	29.8	231	296	H
HO10P3BLF		1200	1180	91.7	91.7	92.1	91.3	80.4	75.5	65.6	12.7	80.3	44.4	208	288	H
HO15P2BLE/G	15	1800	1780	93	93	93.9	93.3	84	81.3	73.8	18	115	44.3	244	253	G
HO15P3BLF		1200	1180	91.7	91.7	92.3	91.8	80.4	75.3	64.9	19.1	116.4	66.8	208	279	G
HO20P1BLF	20	3600	3540	91	91	91.6	91	87	85.7	80.7	23.7	142.1	29.7	156	236	G
HO20P2BLF/G		1800	1775	93	93	94.1	93.9	84.8	83.5	77	23.7	139	59.2	227	230	G
HO20P3BLG		1200	1175	92.4	92.4	93.2	93.1	84.2	80.5	72.3	24.1	149.4	89.2	210	276	G
HO25P1BLF	25	3600	3540	91.7	91	92.4	92.1	88.2	87.5	83.4	29.1	181.3	37.1	165	244	G
HO25P2BLF/G		1800	1775	93.6	93.6	94.5	94.3	85.5	83.6	77.4	29.2	181	74.1	245	242	G
HO25P3BLG		1200	1190	93	92.4	93.3	92.7	81.6	79.2	71.9	31	179.3	110.3	179	222	G
HO30P1BLF	30	3600	3525	91.7	91.7	92.9	92.9	88.8	88.8	85.9	35	198.8	44.7	152	227	F
HO30P2BLF/G		1800	1775	94.1	94.1	94.8	94.5	84.9	82.9	75.5	35	229	88.9	265	258	G
HO30P3BLG		1200	1185	93.6	93	93.7	93.2	85.9	83.3	76.1	35	261.8	132.8	218	272	H
HO40P1BLF	40	3600	3530	92.4	92.4	93.5	93.6	89.3	88.9	85.6	45	297.7	59.5	173	257	G
HO40P2B/SLF/G		1800	1780	94.5	94.1	94.4	93.6	87.8	86.4	81.3	45	286	117.9	192	251	G
HO40P3BLGX		1200	1185	94.1	93	93.9	93.3	86.1	83.4	76.2	47	352	177.3	234	277	H
HO50P1BLF	50	3600	3565	93.0	91.7	91.9	90.3	88.1	87.3	83.2	58	362.5	73.6	183	282	G
HO50P2B/SLF/G		1800	1780	94.5	94.1	94.6	94.1	87.7	86.2	80.9	57	357	147.5	191	251	G
HO50P3BLGX		1200	1185	94.1	94.1	93.9	93.5	85.0	81.5	72.9	59	467.5	221.6	257	293	J
HO60P1SLG	60	3600	3570	93.6	92.4	92.3	90.6	84.7	81.4	73.4	72	525	88.3	220	343	H
HO60P2B/SLG		1800	1785	95	95	95.2	94.8	87.2	85.9	80.9	68	434	176.7	201	242	G
HO60P3SLGX		1200	1190	94.5	94.1	94.4	93.9	86.3	84.6	78.7	69	452.1	264.8	175	238	G
HO75P1SLG	75	3600	3560	93.6	92.4	93.1	92	89.4	89.6	87.1	85	515	110.7	175	268	F
HO75P2B/SLG		1800	1780	95	95	95.3	95	85.3	82.9	75.8	87	539	221.1	203	245	G
HO75P3SLGX		1200	1190	94.5	94.1	94.6	94.3	86.1	84.4	78.5	87	545.6	331.2	173	230	G
HO100P1SLG	100	3600	3555	93.6	91.7	92.4	91	88.1	87.5	83.9	116	723	147.8	190	286	G
HO100P2S/BLG		1800	1785	95.4	95	95.5	95.1	86.3	84.5	78.5	114	737.5	294.3	186	230	G
HO100P2SLGX		1800	1785	95.4	95.4	94.9	94.3	86.3	84.6	78.6	115	737.5	294.3	186	230	G
HO125P2SLG	125	1800	1785	95.4	95	95.7	95.4	86.8	85.2	79.8	142	925.1	368.1	186	231	G
HO125P2SLGX		1800	1785	95.4	94.5	95.2	94.7	86.8	85.3	79.9	143	925.1	368.1	186	231	G
HO150P2SLG/H	150	1800	1780	95.8	95.8	95.9	95.4	89.3	87.7	83.2	164	1036.2	442.1	167	232	F
HO150P2SLGX		1800	1780	95.8	95.4	95.4	94.7	89.3	87.8	83.3	165	1036.2	442.1	167	232	F
HO200P2SLG	200	1800	1780	95.8	95.8	96	95.6	88.2	86.5	81	222	1437.9	589.7	100	200	G
HO200P2SLHX		1800	1780	95.8	95.4	95.7	95.1	88.3	86.6	81.1	222	1437.9	589.8	179	241	G
HO250P2SLHX	250	1800	1780	95.8	95.4	95.6	95.1	86.8	84.5	78	283	1781.9	736.9	168	221	G
HO300P2SLHX	300	1800	1785	95.8	95.4	95.9	95.6	86.6	85.2	79.9	340	2066.9	883.3	100	200	F
HO350P2SLHX	350	1800	1785	95.8	95.8	96.3	96.1	87.9	87.2	83.2	389	2398	1031.2	91	248	F
HO400P2SLHX	400	1800	1785	95.8	95.8	96.3	96.2	90.2	90.2	87.7	433	2859.4	1176.7	101	249	G
HO450P2SLHX	450	1800	1785	96.2	95.8	96.5	96.4	90.1	89.8	86.9	488	3291.7	1323.9	105	256	G
HO500P2SFLHX	500	1800	1785	96.2	95.8	96.4	96.4	88.6	87.6	83.3	551	3828	1473.1	120	264	G
HO500P2SLHX	500	1800	1785	96.2	95.8	96.3	96	90.4	90	85.9	541	3625	1472.7	94	267	G
HO600P2SLJX	600	1800	1780	96.2	96	96.4	96.3	89.4	88.0	83.1	656	4350	1771.7	103	275	G

Efficiency and power factor values listed above are typical values. For guaranteed and certified values, refer to the Technical Service Group. The code letter is an indication of the locked rotor K.V.A in accordance with the National Electrical Code. When performance values have been quoted, they should be shown on the order. Data subject to change without prior notice.

† All marks shown within this document are properties of their respective owners.

Revised — April 2019

# Operating Characteristics - Vertical HOLLOWSHAFT® Motors

## High Thrust - "P" Base, Three Phase, Weather Protected Type (WPI), Premium Efficient, Inverter Duty

CATALOG NUMBER	HP	RPM		% EFFICIENCY				% POWER FACTOR			CURRENT (AMPS) 460 VOLTS		TORQUE AT FULL VOLTAGE (FT. LBS.)			NEMA CODE
													FULL LOAD TORQUE @	LOCKED (STARTING)	PULLOUT BREAK-DOWN	
		NO LOAD	FULL LOAD	NEMA Nom. Eff.	FULL LOAD	3/4 LOAD	1/2 LOAD	FULL LOAD	3/4 LOAD	1/2 LOAD	FULL LOAD	LOCKED STARTING	FULL LOAD SPEED	% OF FULL LOAD		
HO15V2BLE	15	1800	1780	93.6	93	93.9	93.3	84	81.3	73.8	18	115	44.3	244	253	G
HO20V2BLF/G	20	1800	1775	93	93	94.1	93.9	84.8	83.5	77	23.7	139	59.2	227	230	F
HO25V2BLF/G	25	1800	1775	93.6	93.6	94.5	94.3	85.5	83.6	77.4	29.2	181	74.1	245	242	G
HO30V2BLF/G	30	1800	1775	94.1	94.1	94.7	94.5	84.9	82.5	75.5	35	228	88.9	264	256	G
HO40V2BLF/G	40	1800	1780	94.5	94.1	94.4	93.6	87.8	86.4	81.3	45	286	117.9	192	251	G
HO50V2BLG	50	1800	1780	94.5	94.1	94.6	94.1	87.7	86.2	80.9	57	357	147.5	191	251	G
HO60V2SLG	60	1800	1785	95	95	95.2	94.8	87.2	85.9	80.9	68	434	176.7	201	242	G
HO75V2SLG	75	1800	1780	95	94.5	95.3	95	85.4	83	75.8	87	539	221.1	203	245	G
HO100V2SLG	100	1800	1785	95.4	95	95.5	95.1	86.3	84.5	78.5	114	737.5	294.3	186	230	G
HO100V2SLGX		1800	1785	95.4	94.5	94.9	94.3	86.3	84.6	78.6	115	737.5	294.3	186	230	G
HO125V2SLG	125	1800	1785	95.4	95	95.7	95.4	86.8	85.2	79.8	142	925.1	368.1	186	231	G
HO125V2SLGX		1800	1785	95.4	94.5	95.2	94.7	86.8	85.3	79.9	143	925.1	368.1	186	231	G
HO150V2SLG	150	1800	1780	95.8	95.8	95.9	95.4	89.3	87.7	83.2	164	1085	442.1	110	200	G
HO150V2SLGX		1800	1780	95.8	95.4	95.4	94.7	89.3	87.8	83.3	165	1036.2	442.1	167	232	G
HO200V2SLH	200	1800	1780	95.8	95.8	96	95.6	88.2	86.5	81	222	1450	589.7	100	200	G
HO200V2SLHX		1800	1780	95.8	95.4	95.7	95.1	88.3	86.6	81.1	222	1437.9	589.8	179	241	G
HO250V2SLH	250	1800	1780	95.8	95.4	95.9	95.6	86.7	84.5	77.9	283	1781.9	736.8	179	235	G
HO250V2SLHX		1800	1780	95.8	96	95.6	95	86.8	84.5	78	283	1781.9	736.9	179	235	F
HO300V2SLH	300	1800	1785	95.8	95.8	96.2	96	86.6	85.2	79.8	338	2066.9	883.3	90	249	G
HO300V2SLHX		1800	1785	95.8	95.4	95.9	95.6	86.6	85.2	79.9	340	2066.9	883.3	90	249	G
HO350V2SLH	350	1800	1785	95.8	95.8	96.5	96.5	87.9	87.2	83.2	389	2398	1031.2	80	200	G
HO350V2SLHX		1800	1785	95.8	95.8	96.3	96.1	87.9	87.2	83.2	389	2396.9	1031.2	70	210	G
HO400V2SLH	400	1800	1785	96.2	95.8	96.6	96.6	90.2	90.2	87.6	433	2859.4	1176.6	101	250	G
HO400V2SLHX		1800	1785	96.2	95.8	96.3	96.2	90.2	90.2	87.7	433	2859.4	1176.7	101	249	G
HO450V2SLH	450	1800	1785	96.2	96.2	96.7	96.7	90.1	89.8	86.8	486	3291.7	1323.9	105	256	G
HO450V2SLHX		1800	1785	96.2	96.2	96.5	96.4	90.1	89.8	86.9	488	3291.7	1323.9	105	256	G
HO500V2SFLH	500	1800	1785	96.2	95.8	96.7	96.7	88.6	87.6	83.3	551	3828.2	1473	120	264	G
HO500V2SFLHX		1800	1785	96.2	95.8	96.4	96.4	88.6	87.6	83.3	551	3828.2	1473.1	120	264	G
HO500V2SLH		1800	1780	96.2	96.2	96.5	96.4	90.3	88.9	84.3	541	3625	1474.6	109	289	G
HO500V2SLHX		1800	1780	96.2	95.8	96.3	96	90.4	89.6	85.9	541	3625	1472.7	94	267	G
HO600V2SLJX	600	1800	1780	96.2	95.8	96.2	95.8	91	90.4	87.3	644	4734	1771.6	60	175	G

Efficiency and power factor values listed above are typical values. For guaranteed and certified values, refer to the Technical Service Group. The code letter is an indication of the locked rotor K.V.A in accordance with the National Electrical Code. When performance values have been quoted, they should be shown on the order. Data subject to change without prior notice.

† All marks shown within this document are properties of their respective owners.



# Operating Characteristics - Vertical HOLLOWSHAFT® Motors

## High Thrust - "P" Base, Three Phase, Totally Enclosed Fan Cooled (TEFC), Premium Efficient, SINEWAVE OPTIMIZED®

CATALOG NUMBER	HP	RPM		% EFFICIENCY				% POWER FACTOR			CURRENT (AMPS) 460 VOLTS		TORQUE AT FULL VOLTAGE (FT. LBS.)			NEMA CODE
		NO LOAD	FULL LOAD	NEMA Nom. Eff.	FULL LOAD	3/4 LOAD	1/2 LOAD	FULL LOAD	3/4 LOAD	1/2 LOAD	FULL LOAD	LOCKED STARTING	FULL LOAD TORQUE @ SPEED	LOCKED (STARTING)	PULLOUT BREAK- DOWN	
HT5P1BLE	5	3600	3540	88.5	88.5	87.5	84.4	86	83	76	6.2	46.4	7.4	191	333	J
HT5P2BLE		1800	1770	90.2	90.2	90	88.1	76.8	69.9	57.5	6.8	49	14.8	265	359	J
HT7P1BLE	7.5	3600	3530	89.5	89.5	89.4	87.5	86.9	84.5	78	9	62.8	11.2	178	305	H
HT7P2BLE		1800	1765	91.7	91.7	92.3	91.6	85.1	81.8	74.1	9	62	22.3	239	309	H
HT10P1BLE	10	3600	3520	90.2	90.2	90.7	89.4	87.9	86.1	80.5	11.8	80.3	14.9	177	297	H
HT10P2BLE		1800	1765	91.7	91.7	92.7	92.2	85.5	82.1	74.6	11.9	82	29.8	241	308	H
HT15P1BLE	15	3600	3510	91	90.2	91.8	91.3	89.4	87.8	82.7	17.4	129.8	22.5	214	327	H
HT15P2BLE		1800	1775	93	93	93.8	93.3	85.7	83.9	77.9	17.6	110	44.4	236	244	G
HT20P2BLE	20	1800	1770	93	93	93.8	93.7	84.9	83.1	77	23.7	139	59.3	227	230	F
HT25P2BLF	25	1800	1770	93.6	93.6	94.5	94.3	86.6	85.5	80.7	28.9	178	74.1	242	235	G
HT30P2BLF	30	1800	1770	93.6	93	94.3	94	86.1	84.5	79	35	217	89	250	241	G
HT40P2BLG	40	1800	1780	94.5	94.5	95	94.7	86	83.4	76.6	46	284	117.9	192	240	G
HT50P2BLG	50	1800	1780	94.5	94.5	95.1	95	85.7	83.4	76.5	58	359	147.5	198	244	G
HT60P2CLG	60	1800	1785	95	95	95.3	94.9	86.8	85.7	80.8	68	404.9	176.7	169	213	F
HT75P2CLG	75	1800	1785	95.4	95	95.6	95.4	87.3	86.2	81.3	85	522.2	221	176	217	F
HT100P2CLG	100	1800	1785	95.4	95	95.3	94.5	87.3	85.1	78.8	113	723.1	294.3	163	239	G
HT125P2CLG	125	1800	1790	95.4	95	95.3	94.4	83.9	81.1	73.7	147	907.5	367.1	110	200	G
HT150P2CLG	150	1800	1790	95.8	95.8	95.9	95.2	86.3	84.5	78.6	170	1103.3	440.7	116	263	G
HT200P2CLG	200	1800	1785	96.2	96.2	96.4	96	86.8	84.9	78.9	224	1514.7	587.7	124	273	G
HT250P2CLJX	250	1800	1785	96.2	95.8	95.8	95.1	89.6	89.4	86.7	273	1820	734.7	124	256	G
HT300P2CLJX	300	1800	1785	96.2	95.8	95.9	95.3	90.3	90.3	88	325	2215.4	881.5	80	175	G

Efficiency and power factor values listed above are typical values. For guaranteed and certified values, refer to the Technical Service Group. The code letter is an indication of the locked rotor K.V.A in accordance with the National Electrical Code. When performance values have been quoted, they should be shown on the order. Data subject to change without prior notice.

† All marks shown within this document are properties of their respective owners.

Revised — April 2019



# Operating Characteristics - Vertical HOLLOWSHAFT® Motors

## High Thrust - "P" Base, Three Phase, Totally Enclosed Fan Cooled (TEFC) CORRO-DUTY®, Premium Efficient, Inverter Duty

CATALOG NUMBER	HP	RPM		% EFFICIENCY				% POWER FACTOR			CURRENT (AMPS) 460 VOLTS		TORQUE AT FULL VOLTAGE (FT. LBS.)			NEMA CODE
		NO LOAD	FULL LOAD	NEMA Nom. Eff.	FULL LOAD	3/4 LOAD	1/2 LOAD	FULL LOAD	3/4 LOAD	1/2 LOAD	FULL LOAD	LOCKED STARTING	FULL LOAD TORQUE @ SPEED	LOCKED (STARTING)	PULLOUT BREAK- DOWN	
CHT5V1BLE	5	3600	3540	88.5	88.5	87.5	84.4	86	83	76	6.2	46.4	7.4	191	333	J
CHT5V2BLE		1800	1770	89.5	89.5	89.6	87.8	77.3	70.3	57.9	6.8	48	14.8	258	350	J
CHT7V1BLE	7.5	3600	3530	89.5	89.5	89.4	87.5	87	84.5	78	9	62.8	11.2	178	306	H
CHT7V2BLE		1800	1765	91.7	91.7	92.3	91.6	85.1	81.9	74.1	9	62	22.3	240	310	H
CHT10V1BLE	10	3600	3525	90.2	90.2	90.5	89	86	82.8	75	12.1	88.6	14.9	192	322	H
CHT10V2BLE		1800	1765	91.7	91.7	92.5	91.9	84	79.8	70.8	12.2	88	29.8	258	332	H
CHT15V1BLE	15	3600	3540	91	91	90.2	88.4	89.5	88.8	85.3	17.4	117.4	22.3	190	269	G
CHT15V2BLE		1800	1775	92.4	92.4	92.8	91.7	85.6	83.2	76.5	17.8	117	44.3	252	258	G
CHT20V2BLE	20	1800	1775	93	93	93.7	93.3	84.2	81.3	73.6	23.9	151	59.2	246	253	G
CHT25V2BLF	25	1800	1780	93.6	93.6	94.1	93.5	85.3	82.2	74.4	29.3	187	73.8	206	278	G
CHT30V2BLF	30	1800	1775	93.6	93.6	94.1	93.7	84.7	81.1	72.7	35	228	88.7	210	282	G
CHT40V2BLG	40	1800	1780	94.5	94.1	95	94.7	86	83.4	76.6	46	284	117.9	192	240	G
CHT50V2BLG	50	1800	1780	94.5	94.5	95.1	95	85.7	83.4	76.5	58	359	147.5	198	244	G
CHT60V2CLG	60	1800	1785	95	95	95.3	94.9	86.8	85.7	80.8	68	404.9	176.7	169	213	G
CHT75V2CLG	75	1800	1785	95.4	95	95.7	95.3	86.8	84.9	78.8	85	576.3	221	193	240	G
CHT100V2CLG	100	1800	1785	95.4	95	95.3	94.5	87.3	85.1	78.8	113	724.1	294.3	163	239	G
CHT125V2CLG	125	1800	1790	95.4	95	95.3	94.4	83.9	81.1	73.7	147	931.7	367.1	109	262	G
CHT150V2CLG	150	1800	1790	95.8	95.8	95.9	95.2	86.3	84.5	78.6	170	1103.3	440.7	116	263	G
CHT200V2CLG	200	1800	1785	96.2	96.2	96.4	96	86.8	84.9	78.9	224	1514.7	587.8	124	273	G
CHT250V2CLJX	250	1800	1785	96.2	95.8	95.8	95.1	89.6	89.4	86.7	273	1820	734.7	124	256	G
CHT300V2CLJX	300	1800	1785	96.2	95.8	95.9	95.3	90.3	90.3	88	325	2215.4	881.5	94	262	G

Efficiency and power factor values listed above are typical values. For guaranteed and certified values, refer to the Technical Service Group. The code letter is an indication of the locked rotor K.V.A in accordance with the National Electrical Code. When performance values have been quoted, they should be shown on the order. Data subject to change without prior notice.

† All marks shown within this document are properties of their respective owners.



VERTICAL MOTORS  
STEADY BUSHING KITS  
CONVERSION CENTER  
QUICK ENGINEERING FACTS  
FORMULAS  
LONG TERM STORAGE INFORMATION  
OPERATING CHARACTERISTICS  
DIMENSION PRINT INDEX  
DRIVE COUPLING PART NUMBERS  
DIMENSION PRINTS

# Operating Characteristics - Vertical HOLLOWSHAFT® Motors

## High Thrust - "P" Base, Three Phase, Weather Protected Type (WPI), Premium Efficient – IE3, International Duty

CATALOG NUMBER	HP	RPM		% EFFICIENCY				% POWER FACTOR			CURRENT (AMPS) 440 VOLTS		TORQUE AT FULL VOLTAGE (FT. LBS.)			NEMA CODE
		NO LOAD	FULL LOAD	NEMA Nom. Eff.	FULL LOAD	3/4 LOAD	1/2 LOAD	FULL LOAD	3/4 LOAD	1/2 LOAD	FULL LOAD	LOCKED STARTING	FULL LOAD TORQUE @	LOCKED (STARTING)	PULLOUT BREAK-DOWN	
													FULL LOAD SPEED	% OF FULL LOAD		
HO50P2RLG	50	1800	1785	94.5	94.1	94.4	93.8	86.5	84.5	78.3	60	402	147.2	203	256	G
HO60P2RLG	60	1800	1785	95	94.5	95	94.6	87.2	85.5	80	71	481	176.7	211	257	G
HO75P2RLG	75	1800	1785	95.4	95	95.3	94.7	84.4	80.9	72.3	92	677	220.8	248	295	H
HO75P2RGLG	75	1800	1785	95.8	95.4	95.5	94.8	87.7	86.3	81.5	88	661	220.4	190	244	G
HO100P2RLG	100	1800	1785	95.4	95	95.3	94.8	87.2	85.6	80	118	814	294.2	193	241	G
HO125P2RLG	125	1800	1785	95.4	95	95.5	95.2	85.6	83.1	76.1	150	1014.9	368	196	244	G
HO150P2RLG	150	1800	1785	95.8	95.4	95.7	95.2	87.4	85.3	79.1	176	1112.4	441.5	166	233	G
HO200P2RLG	200	1800	1785	96.2	95.8	96.1	95.8	87.8	85.6	79.3	233	1580	588.8	187	249	G
HO250P2RLH	250	1800	1785	96.2	95.8	96.2	95.8	86.2	83.4	75.9	296	2009.5	736.4	196	253	G
HO300P2RLHX	300	1800	1785	96.2	95.8	96.1	95.9	87.2	85.8	80.4	352	2239.6	882	88	255	G
HO350P2RLHX	350	1800	1785	96.2	95.8	96.5	96.4	86.7	84.8	78.9	413	2742.3	1029.2	95	269	G

CATALOG NUMBER	HP	RPM		% EFFICIENCY				% POWER FACTOR			CURRENT (AMPS) 415 VOLTS		TORQUE AT FULL VOLTAGE (FT. LBS.)			NEMA CODE
		NO LOAD	FULL LOAD	IE3 Nom. Eff.	FULL LOAD	3/4 LOAD	1/2 LOAD	FULL LOAD	3/4 LOAD	1/2 LOAD	FULL LOAD	LOCKED STARTING	FULL LOAD TORQUE @	LOCKED (STARTING)	PULLOUT BREAK-DOWN	
													FULL LOAD SPEED	% OF FULL LOAD		
HO50P2TLG	50	1500	1480	94	93.6	93.9	93.3	83.5	79.1	69.4	66.0	443	177.3	207	288	H
HO60P2TLG	60	1500	1485	94.4	94.1	94.4	93.9	81.8	77	66.7	81	555	212.2	227	290	H
HO75P2TLG	75	1500	1485	95	94.6	94.8	94.3	84.7	81.1	72.6	97	696.7	264.9	206	264	H
HO100P2TLG	100	1500	1485	95.2	94.9	95.3	94.9	84.6	81.3	72.9	129	897.6	353.6	205	258	H
HO125P2TLG	125	1500	1485	95.5	95.2	95.3	94.7	86	82.5	74	158	1141.2	441.5	200	273	H
HO150P2TLG	150	1500	1485	95.6	95.3	95.5	94.9	85.9	82.5	74.2	190	1331.8	530.2	199	267	H
HO200P2TLG	200	1500	1485	95.8	95.8	95.9	95.5	83.3	78.9	68.9	261	1770.6	707.7	205	267	H
HO250P2TLH	250	1500	1490	96	96	96.2	95.9	85.6	82.4	74.4	316	2360.6	881.9	117	306	H
HO300P2TLH	300	1500	1490	96.2	96.2	96.6	96.5	87.3	84.7	77.5	371	2891.8	1057.2	128	301	H
HO350P2TLH	350	1500	1490	96.5	96.2	96.6	96.4	90.1	88.8	84.3	419	3398.1	1233.9	130	304	H

Efficiency and power factor values listed above are typical values. For guaranteed and certified values, refer to the Technical Service Group. The code letter is an indication of the locked rotor K.V.A in accordance with the National Electrical Code. When performance values have been quoted, they should be shown on the order. Data subject to change without prior notice.

† All marks shown within this document are properties of their respective owners.

Revised — April 2019

# Operating Characteristics - Vertical Solid Shaft Normal Thrust - "P" Base, Three Phase, WPI, Premium Efficient

CATALOG NUMBER	HP	RPM		% EFFICIENCY				% POWER FACTOR			CURRENT (AMPS) 460 VOLTS		TORQUE AT FULL VOLTAGE (FT. LBS.)			NEMA CODE
		NO LOAD	FULL LOAD	NEMA Nom. Eff.	FULL LOAD	3/4 LOAD	1/2 LOAD	FULL LOAD	3/4 LOAD	1/2 LOAD	FULL LOAD	LOCKED STARTING	FULL LOAD TORQUE @	LOCKED (STARTING)	PULLOUT BREAK- DOWN	
NO3P2BE	3	1800	1770	89.5	89.5	89.5	87.7	82.6	77.3	66.8	4	31	8.9	245	383	K
NO5P2BE	5	1800	1760	89.5	89.5	90.2	89.3	83.4	78.4	67.8	6.3	46	14.9	232	348	J
NO7P2BE	7.5	1800	1760	91	91	91.8	91.3	82.8	78.1	68.4	9	62	22.4	232	304	H
NO10P2BE	10	1800	1760	91.7	91.7	92.6	92.4	85.5	82.5	75.2	12	75	29.9	219	280	G
NO15P2BE	15	1800	1780	93	93	93.9	93.3	84	81.3	73.8	17.9	115	44.3	244	253	G
NO20P2BE	20	1800	1775	93	93	93.8	93.4	83.8	80.6	72.3	24	151	59	246	253	G
NO25P2BE	25	1800	1775	93.6	93.6	94.4	94	83.9	80.9	72.9	29.8	193.0	73.9	261	261	G
NO30P2BE	30	1800	1775	94.1	94.1	94.8	94.7	85.8	84.5	78.2	35	217	88.8	249	242	G
NO40P2BG	40	1800	1780	94.1	94.1	95.3	94.9	87.8	86.4	81.1	45	286	117.9	192	252	G
NO50P2BG	50	1800	1780	94.5	94.5	95.3	95.1	87.7	86.1	80.7	57	357.0	147.5	191	252	G
NO100P2BG	100	1800	1785	95.4	95.4	96	95.7	86.3	84.5	78.3	114	737.5	294.3	186	231	G
NO125P2BG	125	1800	1785	95.4	95.4	96	96	87.2	86.1	81.4	141	882.3	368.2	177	220	G

Efficiency and power factor values listed above are typical values. For guaranteed and certified values, refer to the Technical Service Group. The code letter is an indication of the locked rotor K.V.A in accordance with the National Electrical Code. When performance values have been quoted, they should be shown on the order. Data subject to change without prior notice.

† All marks shown within this document are properties of their respective owners.



# Operating Characteristics - Vertical Solid Shaft

## Normal Thrust - "P" Base, Three Phase Totally Enclosed Fan Cooled (TEFC)

### CORRO-DUTY<sup>®</sup>, Premium Efficient - IE3

CATALOG NUMBER	HP	RPM		% EFFICIENCY				% POWER FACTOR			CURRENT (AMPS) 460 VOLTS		TORQUE AT FULL VOLTAGE (FT. LBS.)			NEMA CODE
													FULL LOAD TORQUE @	LOCKED (STARTING)	PULLOUT BREAK-DOWN	
		NO LOAD	FULL LOAD	NEMA Nom. Eff.	FULL LOAD	3/4 LOAD	1/2 LOAD	FULL LOAD	3/4 LOAD	1/2 LOAD	FULL LOAD	LOCKED STARTING	FULL LOAD SPEED	% OF FULL LOAD		
CNT3P1DE	3	3600	3540	87.5	87.5	88	85.8	82.8	77.4	67.1	3.9	32	4.5	251	336	K
CNT3P2DE		1800	1765	89.5	89.5	89.7	88.2	80.1	73.8	61.9	3.9	31	8.9	242	379	K
CNT5P1DE	5	3600	3520	88.5	88.5	90	89.3	87	83.6	75.6	6.1	46	7.5	237	300	J
CNT5P2DE		1800	1755	89.5	89.5	90.7	90.2	83.6	78.7	68.5	6.3	46	15	231	341	J
CNT7P1DE	7.5	3600	3530	91	91	91.4	90.3	86.8	84.4	78	8.9	62.8	11.2	177	305	H
CNT7P2DE		1800	1765	91.7	91.7	92.1	91.3	82.8	78.2	68.4	9.3	65	22.3	247	324	H
CNT10P1DE	10	3600	3520	91	91	92	91.4	87.9	85.8	80	11.8	79.3	14.9	173	292	G
CNT10P2DE		1800	1760	91.7	91.7	92.6	92.3	85.4	82.2	74.7	12	80	29.8	232	297	H
CNT15P1DE	15	3600	3545	91	91	91.3	90.3	88.1	86.8	82.2	17.5	115.4	22.2	175	258	G
CNT15P2DE		1800	1775	92.4	92.4	93.4	93	82.8	79.4	70.7	18.4	112	44.4	233	248	G
CNT20P1DE	20	3600	3535	91	91	91.9	91.5	89.1	88.5	84.9	23.1	148.3	29.7	174	250	G
CNT20P2DE		1800	1770	93	93	94.3	94.2	85.5	83.6	77.3	23.5	142	59.3	235	237	G
CNT25P1FE	25	3600	3560	91.7	91.7	92	90.8	86.7	85.4	80.2	29.4	182	36.9	178	232	G
CNT25P2FE		1800	1775	93.6	93.6	94.2	93.9	85.9	83.2	75.9	29.1	179	73.9	200	265	G
CNT30P1FE	30	3600	3560	91.7	91.7	92.8	92.1	88.9	89	86.3	34	218	44.3	195	229	G
CNT30P2FE		1800	1775	93.6	93.6	94.4	94.3	87	85.1	79.2	34	218	88.8	194	256	G
CNT40P1FG	40	3600	3560	92.4	92.4	92.9	91.8	89	88.6	85.2	46	295	59	185	283	G
CNT40P2FG		1800	1780	94.1	94.1	94.7	94.5	86.8	84.4	77.3	46	295	118	192	258	G
CNT50P1FG	50	3600	3550	93	93	93.3	92.7	90	90.2	87.9	56	365	73.9	197	284	G
CNT50P2FG		1800	1780	94.5	94.5	95.2	95.1	88.4	86.7	81.1	56	377	147.7	210	265	G
CNT60P1FG	60	3600	3570	93.6	93.6	93.5	92.5	88.9	87.4	82.4	68	435	88.3	142	299	G
CNT60P2FG		1800	1785	95	95	95.4	95	86.1	83.8	77.1	69	450.8	176.6	182	234	G
CNT75P1FG	75	3600	3565	93.6	93.6	94.2	93.5	90.2	89.3	85.3	83	546	110.4	149	304	G
CNT75P2FG		1800	1785	95.4	95.4	95.9	95.8	87.2	86.1	81.2	84	523.3	221	176	218	G
CNT100P1FG	100	3600	3560	94.5	94.5	94.7	94.1	88.7	87.5	82.8	112	726	147.4	123	256	G
CNT100P2FG		1800	1780	95.4	95.4	95.6	95.1	87.1	84.8	78.3	113	716.9	294.7	165	241	G
CNT125P1FG	125	3600	3575	95.8	95.8	96.2	95.9	85.8	83.1	75.6	142	923	183.7	125	256	G
CNT125P2FG		1800	1785	95.4	95.4	95.4	94.8	83.9	81	73.5	147	933.9	368.1	122	265	G
CNT150P1FG	150	3600	3570	95.8	95.8	96.2	96.1	85.8	83	75.5	171	1088	220.5	126	252	G
CNT150P2FG		1800	1785	95.8	95.8	96.1	95.7	85.5	83.3	76.7	171	1149.5	441.7	127	273	G
CNT200P1FG	200	3600	3575	96.2	96.2	96.7	96.6	89.7	88.2	83	217	1569	294	146	276	G
CNT200P2FG		1800	1785	96.2	96.2	96.6	96.4	86.8	85.8	81.3	224	1451	588.6	109	241	G

Efficiency and power factor values listed above are typical values. For guaranteed and certified values, refer to the Technical Service Group. The code letter is an indication of the locked rotor K.V.A in accordance with the National Electrical Code. When performance values have been quoted, they should be shown on the order. Data subject to change without prior notice.

† All marks shown within this document are properties of their respective owners.

Revised — April 2019

# Operating Characteristics - Vertical C-Face Three Phase Totally Enclosed Fan Cooled (TEFC) CORRO-DUTY®, Premium Efficient - IE3

CATALOG NUMBER	HP	RPM		% EFFICIENCY				% POWER FACTOR			CURRENT (AMPS) 460 VOLTS		TORQUE AT FULL VOLTAGE (FT. LBS.)			NEMA CODE
		NO LOAD	FULL LOAD	NEMA Nom. Eff.	FULL LOAD	3/4 LOAD	1/2 LOAD	FULL LOAD	3/4 LOAD	1/2 LOAD	FULL LOAD	LOCKED STARTING	FULL LOAD TORQUE @	LOCKED (STARTING)	PULLOUT BREAK-DOWN	
													FULL LOAD SPEED	% OF FULL LOAD		
C1P1DCR	1	3600	3520	80	80	79.9	75.8	86	80.6	71	1.4	12.7	1.5	290	420	M
C1P2DCR		1800	1755	85.5	85.5	84.4	81.1	73.2	64.4	51.3	1.5	13.3	3	398	509	M
C32P1DCR	1.5	3600	3505	84	84	83.4	80.4	86.7	81.7	71.8	2	18.6	2.2	325	429	L
C32P2DCR		1800	1740	86.5	86.5	86.2	83.6	76.1	67.8	54.7	2	19.5	4.5	369	489	M
C2P1DCR	2	3600	3495	86.5	86.5	87.3	85.7	88.5	84.2	75	2.4	25.3	3	342	445	M
C2P2DCR		1800	1745	86.5	86.5	86.6	84.4	77.3	68.6	54.9	2.8	26.4	6	402	513	M
C3P1DCR	3	3600	3540	87.5	87.5	88	85.8	82.8	77.4	67.1	3.9	32	4.5	251	336	K
C3P2DCR		1800	1765	89.5	89.5	89.7	88.2	80.1	73.8	61.9	3.9	31	8.9	242	379	K
C5P1DCR	5	3600	3520	88.5	88.5	90	89.3	87	83.6	75.6	6.1	46	7.5	237	300	J
C5P2DCR		1800	1755	89.5	89.5	90.7	90.2	83.6	78.7	68.5	6.3	46	15	231	341	J
C7P1DCR	7.5	3600	3530	91	91	91.4	90.3	86.8	84.4	78	8.9	62.8	11.2	177	305	H
C7P2DCR		1800	1765	91.7	91.7	92.1	91.3	82.8	78.2	68.4	9.3	65	22.3	247	324	H
C10P1DCR	10	3600	3520	91	91	92	91.4	87.6	95.8	80	11.8	79.3	14.9	173	292	G
C10P2DCR		1800	1760	91.7	91.7	92.6	92.3	85.4	82.2	74.7	12	80	29.8	232	297	H
C15P1DCR	15	3600	3540	91	91	91.3	90.3	88.1	86.8	82.2	17.5	115.4	22.2	175	258	G
C15P2DCR		1800	1775	92.4	92.4	93.4	93	82.8	79.4	70.7	18.4	112	44.4	233	248	G
C20P1DCR	20	3600	3535	91	91	91.9	91.5	89.1	88.5	84.9	23.1	148.3	29.7	174	250	G
C20P2DCR		1800	1770	93	93	94.3	94.2	85.5	83.6	77.3	23.5	142	59.3	235	237	G
C25P1FSCR	25	3600	3560	91.7	91.7	92	90.8	86.7	85.4	80.2	29.4	182	36.9	178	232	G
C25P2FCR		1800	1775	93.6	93.6	94.2	93.9	85.9	83.2	75.9	29.1	179	73.9	200	265	G
C25P2FSCR		1800	1775	93.6	93.6	94.2	93.9	85.9	83.2	75.9	29.1	179	73.9	200	265	G
C30P1FSCR	30	3600	3560	91.7	91.7	92.8	92.1	88.9	89	86.3	34	218	44.3	195	229	G
C30P2FCR		1800	1775	93.6	93.6	94.4	94.3	87	85.1	79.2	34	218	88.8	194	256	G
C30P2FSCR		1800	1775	93.6	93.6	94.4	94.3	87	85.1	79.2	34	218	88.8	194	256	G
C40P1FSCR	40	3600	3560	92.4	92.4	92.9	91.8	89	88.6	85.2	46	295	59	185	283	G
C40P2FCR		1800	1780	94.1	94.1	94.7	94.5	86.8	84.4	77.3	46	295	118	192	258	G
C40P2FSCR		1800	1780	94.1	94.1	94.7	94.5	86.8	84.4	77.3	46	295	118	192	258	G
C50P1FSCR	50	3600	3550	93	93	93.3	92.7	90	90.2	87.9	56	365	73.9	197	284	G
C50P2FCR		1800	1780	94.5	94.5	95.2	95.1	88.4	86.7	81.1	56	377	147.7	210	265	G
C50P2FSCR		1800	1780	94.5	94.5	95.2	95.1	88.4	86.7	81.1	56	377	147.7	210	265	G
C60P1FSCR	60	3600	3570	93.6	93.6	93.5	92.5	88.9	87.4	82.4	68	435	88.3	142	299	G
C60P2FCR		1800	1785	95	95	95.4	95	86.1	83.8	77.1	69	450.8	176.6	182	234	G
C60P2FSCR		1800	1785	95	95	95.4	95	86.1	83.8	77.1	69	450.8	176.6	182	234	G
C75P1FSCR	75	3600	3565	93.6	93.6	94.2	93.5	90.2	89.3	85.3	83	546	110.4	149	304	G
C75P2FCR		1800	1785	95.4	95.4	95.9	95.8	87.2	86.1	81.2	84	523.3	221	176	218	G
C75P2FSCR		1800	1785	95.4	95.4	95.9	95.8	87.2	86.1	81.2	84	523.3	221	176	218	G
C100P1FSCR	100	3600	3560	94.5	94.5	94.7	94.1	88.7	87.5	82.8	112	726	147.4	123	256	G
C100P2FCR		1800	1780	95.4	95.4	95.6	95.1	87.1	84.8	78.3	113	716.9	294.7	165	241	G
C100P2FSCR		1800	1780	95.4	95.4	95.6	95.1	87.1	84.8	78.3	113	716.9	294.7	165	241	G
C125P1FSCR	125	3600	3575	95.8	95.8	96.2	95.9	85.8	83.1	75.6	142	923	183.7	125	256	G
C125P2FCR		1800	1785	95.4	95.4	95.4	94.8	83.9	81	73.5	147	933.9	368.1	122	265	G
C125P2FSCR		1800	1785	95.4	95.4	95.4	94.8	83.9	81	73.5	147	933.9	368.1	122	265	G

† All marks shown within this document are properties of their respective owners.



VERTICAL MOTORS  
 STEADY BUSHING KITS  
 CONVERSION CENTER  
 QUICK ENGINEERING FACTS  
 FORMULAS  
 LONG-TERM STORAGE INFORMATION  
 OPERATING CHARACTERISTICS  
 DIMENSION PRINT INDEX  
 DRIVE COUPLING PART NUMBERS  
 DIMENSION PRINTS

## Operating Characteristics - Vertical C-Face Three Phase Totally Enclosed Fan Cooled (TEFC) CORRO-DUTY<sup>®</sup>, Premium Efficient - IE3 *(continued)*

CATALOG NUMBER	HP	RPM		% EFFICIENCY				% POWER FACTOR			CURRENT (AMPS) 460 VOLTS		TORQUE AT FULL VOLTAGE (FT. LBS.)			NEMA CODE
		NO LOAD	FULL LOAD	NEMA Nom. Eff.	FULL LOAD	3/4 LOAD	1/2 LOAD	FULL LOAD	3/4 LOAD	1/2 LOAD	FULL LOAD	LOCKED STARTING	FULL LOAD TORQUE @	LOCKED (STARTING)	PULLOUT BREAK- DOWN	
													FULL LOAD SPEED	% OF FULL LOAD		
C150P1FSCR	150	3600	3570	95.8	95.8	96.2	96.1	85.8	83	75.5	171	1088	220.5	126	252	G
C150P2FCR		1800	1785	95.8	95.8	96.1	95.7	85.5	83.3	76.7	171	1149.5	441.7	127	273	G
C150P2FSCR		1800	1785	95.8	95.8	96.1	95.7	85.5	83.3	76.7	171	1149.5	441.7	127	273	G
C200P1FSCR	200	3600	3575	96.2	96.2	96.7	96.6	89.7	88.2	83	217	1569	294	146	276	G
C200P2FCR		1800	1785	96.2	96.2	96.6	96.4	86.8	85.8	81.3	224	1451	588.6	109	241	G
C200P2FSCR		1800	1785	96.2	96.2	96.6	96.4	86.8	85.8	81.3	224	1451	588.6	109	241	G

Efficiency and power factor values listed above are typical values. For guaranteed and certified values, refer to the Technical Service Group. The code letter is an indication of the locked rotor K.V.A in accordance with the National Electrical Code. When performance values have been quoted, they should be shown on the order. Data subject to change without prior notice.

† All marks shown within this document are properties of their respective owners.

Revised — April 2019

## HOLLOSHAFT® MOTORS DRIVE COUPLINGS

Frame	Type	Page
182-286	AU, AUC, TU, TUC	E-16
324-405	RU, TU	E-17
405-5008	RU, TU, JU	E-18

## SINGLE AND THREE PHASE HOLLOSHAFT® MOTORS

Phase	Enclosure	Type	Frame	Page
Single	WPI	High Thrust	213-256	E-19
Three	WPI	High Thrust	182-184	E-20
Three	WPI	High Thrust	213-215	E-21
Three	WPI	High Thrust	254-256	E-22
Three	WPI	High Thrust	284-286	E-23
Three	WPI	High Thrust	324-326	E-24
Three	WPI	High Thrust	364-365	E-25
Three	WPI	High Thrust	404-405	E-26
Three	WPI	High Thrust	H444-H445	E-27
Three	WPI	High Thrust	447	E-28
Three	WPI	High Thrust	449	E-29
Three	WPI	High Thrust	5000	E-30
Three	TEFC	High Thrust	182-H215	E-31
Three	TEFC	High Thrust	254-256	E-32
Three	TEFC	High Thrust	284-286	E-33
Three	TEFC	High Thrust	324-326	E-34
Three	TEFC	High Thrust	364-365	E-35
Three	TEFC	High Thrust	404-405	E-36
Three	TEFC	High Thrust	444-447	E-37
Three	TEFC	High Thrust	449	E-38

## THREE PHASE SOLID SHAFT

Enclosure	Type	Frame	Frame
WPI	Normal Thrust	182-184	E-39
WPI	Normal Thrust	213-215	E-40
WPI	Normal Thrust	254-256	E-41
WPI	Normal Thrust	284-286	E-42
WPI	Normal Thrust	324-326	E-43
WPI	Normal Thrust	364-365	E-44
WPI	Normal Thrust	404-405	E-45
TEFC	Normal Thrust	140-286 HP	E-46
TEFC	Normal Thrust	324-447 HP	E-47
TEFC	Vertical C-Face	140 TC	E-48
TEFC	Vertical C-Face	180-405 TC	E-49
TEFC	Vertical C-Face	440 TC	E-50





# HOLLOSHAFT®

## Drive Coupling Part Numbers

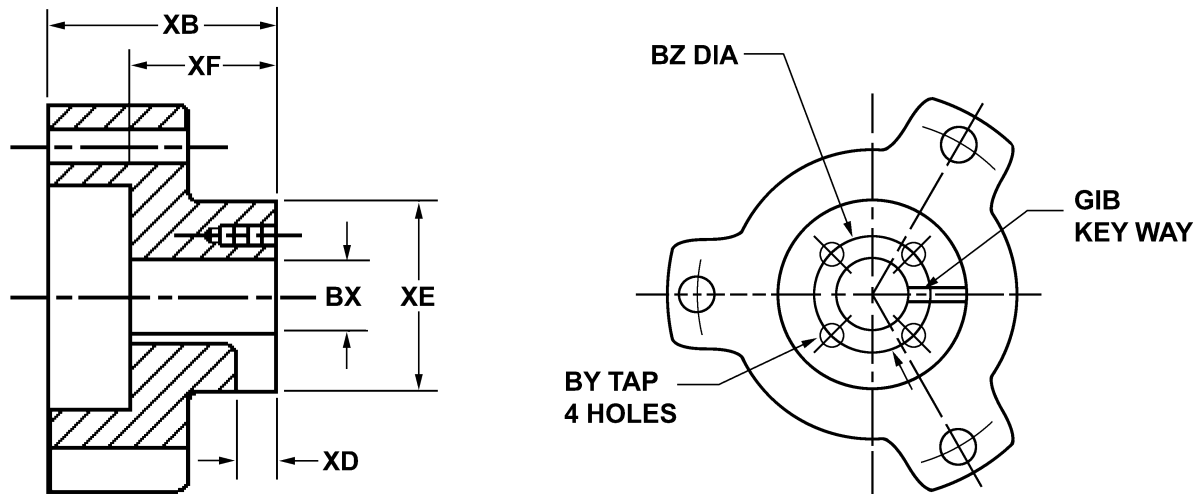

FRAME	TYPE	PART NO.	BORE SIZE		KEY	BY	BZ	XB	XD	XE	XF
			NOMINAL	ACTUAL							
182-215	AUS, AUSI, TUS, TUCI, AUR	159002	0.750	0.751	0.188	10-32	1.375	1.750	0.344	2.000	1.125
		181107	0.875	0.876	0.188	10-32	1.375	1.750	0.406	2.000	1.125
		159001	1.000	1.001	0.250	10-32	1.375	1.750	0.406	2.000	1.125
		157744	BLANK	0.624	-	-	-	1.750	-	2.000	1.125
254-256	AUS, AUSI, TUS, TUCI, AUC	174431	0.750	0.751	0.188	10-32	1.375	2.563	0.344	2.250	1.625
		181105	0.875	0.876	0.188	10-32	1.375	2.563	0.344	2.250	1.625
		B 102999	1.000	1.001	0.250	10-32	1.375	2.563	0.406	2.250	1.625
		779353*	1.063	1.063	0.250	10-32	1.375	2.563	0.406	2.250	1.625
		B 104720	1.188	1.188	0.250	.25-20	1.750	2.563	0.406	2.250	1.625
		152434	1.250	1.251	0.250	.25-20	1.750	2.563	0.406	2.250	1.625
		366983	1.250	1.251	0.375	.25-20	1.750	2.563	0.531	2.250	1.625
		B 102986	BLANK	0.751	-	-	-	2.563	-	2.250	1.625
284-286	AUS, AUSI, TUS	174431	0.750	0.751	0.188	10-32	1.375	2.563	0.344	2.250	1.625
		181105	0.875	0.876	0.188	10-32	1.375	2.563	0.344	2.250	1.625
		B 102999	1.000	1.001	0.250	10-32	1.375	2.563	0.406	2.250	1.625
		779353*	1.063	1.063	0.250	10-32	1.375	2.563	0.406	2.250	1.625
		B 104720	1.188	1.188	0.250	.25-20	1.750	2.563	0.406	2.250	1.625
		152434	1.250	1.251	0.250	.25-20	1.750	2.563	0.406	2.250	1.625
		366983	1.250	1.251	0.375	.25-20	1.750	2.563	0.531	2.250	1.625
		B 102986	BLANK	0.751	-	-	-	2.563	-	2.250	1.625
284-286	TUCI	A 112000-000	1.000	1.001	0.250	10-32	1.375	2.563	0.406	2.625	1.625
		A 108186-000	1.188	1.188	0.250	.25-20	1.750	2.563	0.406	2.625	1.625
		922970*	1.313	1.313	0.250	.25-20	1.750	2.563	0.406	2.625	1.625
		162457-000	1.250	1.251	0.250	.25-20	1.750	2.563	0.406	2.625	1.625
		366982-000	1.250	1.251	0.375	.25-20	1.750	2.563	0.531	2.625	1.625
		661737*	1.500	1.501	0.250	.25-20	2.125	2.563	0.406	2.625	1.625
		B 108184-000	BLANK	0.751	-	-	-	2.563	-	2.625	1.625

\*\* Gib key is not included.

† All marks shown within this document are properties of their respective owners.

Revised — April 2019

# HOLLOSHAFT®

## Drive Coupling Part Numbers

FRAME	TYPE	PART NO.	BORE SIZE		KEY	BY	BZ	XB	XD	XE	XF
			NOMINAL	ACTUAL							
324-326	RUS, RUSI, TUS, TUCI	136731	1.000	1.001	0.250	10-32	1.375	2.938	0.406	2.875	1.938
		132607	1.188	1.188	0.250	.25-20	1.750	2.938	0.406	2.875	1.938
		162458	1.250	1.251	0.250	.25-20	1.750	2.938	0.406	2.875	1.938
		132608	1.250	1.251	0.375	.25-20	1.750	2.938	0.531	2.875	1.938
		795905*	1.313	1.313	0.375	.25-20	1.750	2.938	0.531	2.875	1.938
		132609	1.438	1.438	0.375	.25-20	2.125	2.938	0.531	2.875	1.938
		132610	1.500	1.501	0.375	.25-20	2.125	2.938	0.531	2.875	1.938
		B 108565	BLANK	0.751	-	-	-	2.938	-	2.875	1.938
364-365	RUS, RUSI	136731	1.000	1.001	0.250	10-32	1.375	2.938	0.406	2.875	1.938
		132607	1.188	1.188	0.250	.25-20	1.750	2.938	0.406	2.875	1.938
		162458	1.250	1.251	0.250	.25-20	1.750	2.938	0.406	2.875	1.938
		132608	1.250	1.251	0.375	.25-20	1.750	2.938	0.531	2.875	1.938
		795905*	1.313	1.313	0.375	.25-20	1.750	2.938	0.531	2.875	1.938
		132609	1.438	1.438	0.375	.25-20	2.125	2.938	0.531	2.875	1.938
		132610	1.500	1.501	0.375	.25-20	2.125	2.938	0.531	2.875	1.938
		B 108565	BLANK	0.751	-	-	-	2.938	-	2.875	1.938
364-365	TUS, TUCI	471208*	1.000	1.001	0.250	.25-20	1.375	3.813	0.406	3.625	2.750
		172313	1.188	1.188	0.250	.25-20	1.750	3.813	0.406	3.625	2.750
		172315	1.250	1.251	0.250	.25-20	1.750	3.813	0.406	3.625	2.750
		366985	1.250	1.251	0.375	.25-20	1.750	3.813	0.531	3.625	2.750
		172314	1.438	1.438	0.375	.25-20	2.125	3.813	0.531	3.625	2.750
		118296	1.500	1.501	0.375	.25-20	2.125	3.813	0.531	3.625	2.750
		929360*	1.563	1.563	0.375	.25-20	2.125	3.813	0.531	3.625	2.750
		789957*	1.625	1.626	0.375	.25-20	2.125	3.813	0.531	3.625	2.750
		118297*	1.688	1.688	0.375	.25-20	2.500	3.813	0.531	3.625	2.750
		118298*	1.750	1.751	0.375	.25-20	2.500	3.813	0.531	3.625	2.750
		118295	BLANK	0.751	-	-	-	3.813	-	3.625	2.750
404-405	RUS, RUSI	133000	1.188	1.188	0.250	.25-20	1.750	3.406	0.406	3.125	2.406
		707806*	1.250	1.251	0.250	.25-20	1.750	3.406	0.406	3.125	2.406
		661856	1.250	1.251	0.375	.25-20	1.750	3.406	0.531	3.125	2.406
		133002	1.438	1.438	0.375	.25-20	2.125	3.406	0.531	3.125	2.406
		133003	1.500	1.501	0.375	.25-20	2.125	3.406	0.531	3.125	2.406
		766777*	1.563	1.563	0.375	.25-20	2.500	3.406	0.531	3.125	2.406
		149451	1.688	1.688	0.375	.25-20	2.500	3.406	0.531	3.125	2.406
		928124*	1.813	1.813	0.375	.25-20	2.500	3.406	0.531	3.125	2.406
		133005	BLANK	0.751	-	-	-	3.406	-	3.125	2.406

\*\* Gib key is not included.

\*Product listed may not be available from stock.

† All marks shown within this document are properties of their respective owners.



# HOLLOSHAFT®

## Drive Coupling Part Numbers

FRAME	TYPE	PART NO.	BORE SIZE		KEY	BY	BZ	XB	XD	XE	XF
			NOMINAL	ACTUAL							
404-405	TUS, TUCI	172314	1.438	1.438	0.375	.25-20	2.125	3.813	0.531	3.625	2.750
		118296	1.500	1.501	0.375	.25-20	2.125	3.813	0.531	3.625	2.750
		929360*	1.563	1.563	0.375	.25-20	2.125	3.813	0.531	3.625	2.750
		789957*	1.625	1.626	0.375	.25-20	2.125	3.813	0.531	3.625	2.750
		118297	1.688	1.688	0.375	.25-20	2.500	3.813	0.531	3.625	2.750
		118298*	1.750	1.751	0.375	.25-20	2.500	3.813	0.531	3.625	2.750
		926393*	1.875	1.876	0.500	.25-20	2.500	3.813	0.531	3.625	2.750
		118299*	1.938	1.938	0.500	.25-20	2.500	3.813	0.531	3.625	2.750
		118295	BLANK	0.751	-	-	-	3.813	-	3.625	2.750
H444-447	RUS, RUSI	945496*	1.313	1.313	0.375	.25-20	2.125	4.000	0.688	3.688	2.875
		132576	1.438	1.438	0.375	.25-20	2.125	4.000	0.688	3.688	2.875
		132577	1.500	1.501	0.375	.25-20	2.125	4.000	0.531	3.688	2.875
		132578	1.688	1.688	0.375	.25-20	2.500	4.000	0.531	3.688	2.875
		742204*	1.750	1.751	0.375	.25-20	2.500	4.000	0.531	3.688	2.875
		132579	1.938	1.938	0.500	.25-20	2.500	4.000	0.688	3.688	2.875
		934083*	2.125	2.126	0.500	.375-16	3.250	4.000	0.688	4.000	2.875
		136874	2.188	2.188	0.500	.375-16	3.250	4.000	0.688	4.000	2.875
		136875	2.250	2.251	0.500	.375-16	3.250	4.000	0.688	4.000	2.875
		131805	BLANK	0.751	-	-	-	4.000	-	3.688	2.875
444-447	TUS, TUCI	172314	1.438	1.438	0.375	.25-20	2.125	3.813	0.531	3.875	2.750
		118296	1.500	1.501	0.375	.25-20	2.125	3.813	0.531	3.875	2.750
		929360*	1.563	1.563	0.375	.25-20	2.125	3.813	0.531	3.875	2.750
		789957*	1.625	1.626	0.375	.25-20	2.125	3.813	0.531	3.875	2.750
		118297	1.688	1.688	0.375	.25-20	2.500	3.813	0.531	3.875	2.750
		118298	1.750	1.751	0.375	.25-20	2.500	3.813	0.531	3.875	2.750
		926393*	1.875	1.876	0.500	.25-20	2.500	3.813	0.531	3.875	2.750
		118299	1.938	1.938	0.500	.25-20	2.500	3.813	0.531	3.875	2.750
		118295-000	BLANK	0.751	-	-	-	2.563	-	3.625	2.750
449-5008	RUS, RUSI, RUE, RUEI, JUE, JUCEI	129679	1.688	1.688	0.375	.25-20	2.500	4.375	0.531	4.750	3.063
		A 113288	1.938	1.938	0.500	.25-20	2.500	4.375	0.688	4.750	3.063
		A 113287	2.125	2.126	0.500	.375-16	3.250	4.375	0.688	4.750	3.063
		A 113289	2.188	2.188	0.500	.375-16	3.250	4.375	0.688	4.750	3.063
		863877	2.250	2.251	0.500	.375-16	3.250	4.375	0.688	4.750	3.063
		A 113313	2.375	2.376	0.625	.375-16	3.250	4.375	25/32	4.750	3.063
		A 113290	2.438	2.438	0.625	.375-16	3.250	4.375	25/32	4.750	3.063
		A 113314	2.500	2.501	0.625	.375-16	3.750	4.375	25/32	4.750	3.063
				A 113285	BLANK	-	-	-	-	4.375	-
5012	RUE, RUEI	803186*	1.688	1.688	0.375	.250-20	2.500	5.125	0.500	5.000	3.625
		235069*	1.938	1.938	0.500	.250-20	2.500	5.125	0.500	5.000	3.625
		248380*	2.125	2.126	0.625	.375-16	3.250	5.125	0.500	5.000	3.625
		143112*	2.188	2.188	0.500	.375-16	3.250	5.125	0.500	5.000	3.625
		238062*	2.250	2.251	0.500	.375-16	3.250	5.125	0.500	5.000	3.625
		A143113*	2.438	2.438	0.625	.375-16	3.250	5.125	0.500	5.000	3.625
		249156*	2.500	2.501	0.625	.375-16	3.250	5.125	0.500	5.000	3.625
		143115*	2.688	2.688	0.625	.375-16	3.750	5.125	0.500	5.000	3.625
		143116*	2.750	2.751	0.625	.375-16	3.250	5.125	0.500	5.000	3.625
				143111*	BLANK	BLANK	-	-	-	5.125	-

\*Product listed may not be available from stock.

\*\* Gib key is not included.

† All marks shown within this document are properties of their respective owners.

Revised — April 2019



# Dimension Prints

## Single Phase HOLLOWSHAFT® Motors, Weather Protected Type I (AUR, AUC), Frame 213 Thru 256 UP

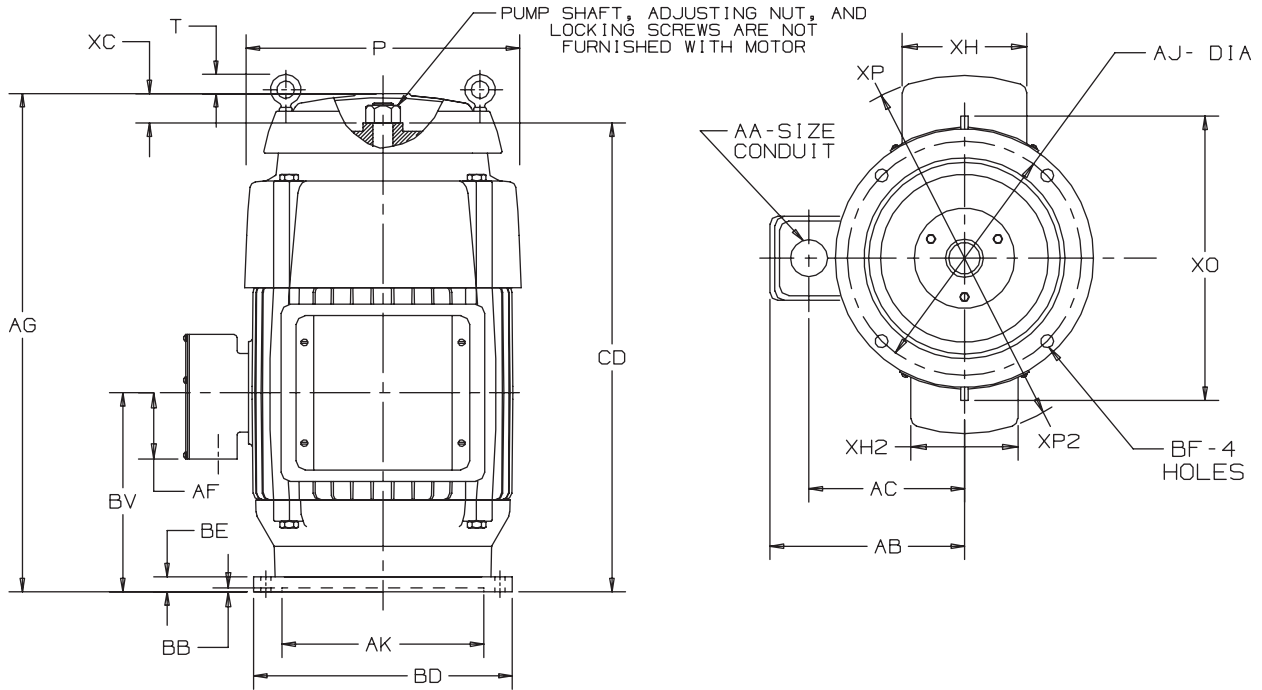

ALL DIMENSIONS ARE IN INCHES & MILLIMETERS

BASIC FRAME	UNITS	P <sup>2</sup>	T	AG	AJ	AK +.003	BB MIN	BE	BF	BV	CD	XC	X0
210	IN	12.88	1.50	21.25	9.125	8.250	.19	.75	.44	8.00	17.56	3.34	---
	mm	327	38	540	231.78	209.55	5	19	11	203	446	85	---
250	IN	14.00	---	26.75	9.125	8.250	.25	.94	.44	11.50	23.38	3.22	16.88
	mm	356	---	679	231.78	209.55	6	24	11	292	294	82	429

FRAME	TYPE	UNITS	AA	AB	AC	AF	BD	XH	XH2	XP	XP2
215P (5HP, 2 POLE)	AUR	IN	3/4 NPT	7.94	6.94	3.06	10.00	6.13	6.13	8.75	7.75
		mm		202	176	78	254	156	156	222	197
213P, 215P	AUR	IN	3/4 NPT	7.94	6.94	3.06	10.00	6.13	---	7.75	---
		mm		202	176	78	254	156	---	197	---
254UP, 256UP	AUC	IN	1-1/4 NPT	8.94	7.75	3.59	10.00	7.50	7.00	10.56	9.69
		mm		227	197	91	254	191	178	268	246
254UPH, 256UPH	AUC	IN	1-1/4 NPT	8.94	7.75	3.59	12.00	7.50	7.00	10.56	9.69
		mm		227	197	91	305	191	178	268	246

TOLERANCES	
FACE RUNOUT	.004 F.I.R.
PERMISSIBLE ECCENTRICITY OF MOUNTING RABBET	.004 F.I.R.

- 1: ALL ROUGH CASTING DIMENSIONS MAY VARY BY .25" DUE TO CASTING VARIATIONS.
- 2: LARGEST MOTOR WIDTH.
- 3: CONDUIT BOX MAY BE LOCATED IN STEPS OF 90° STANDARD AS SHOWN WITH CONDUIT OPENING DOWN.
- 4: TOLERANCES SHOWN ARE IN INCHES ONLY.



# Dimension Prints

## HOLLOSHAFT® Motors, Weather Protected Type I (AU), Frame 182 & 184TP

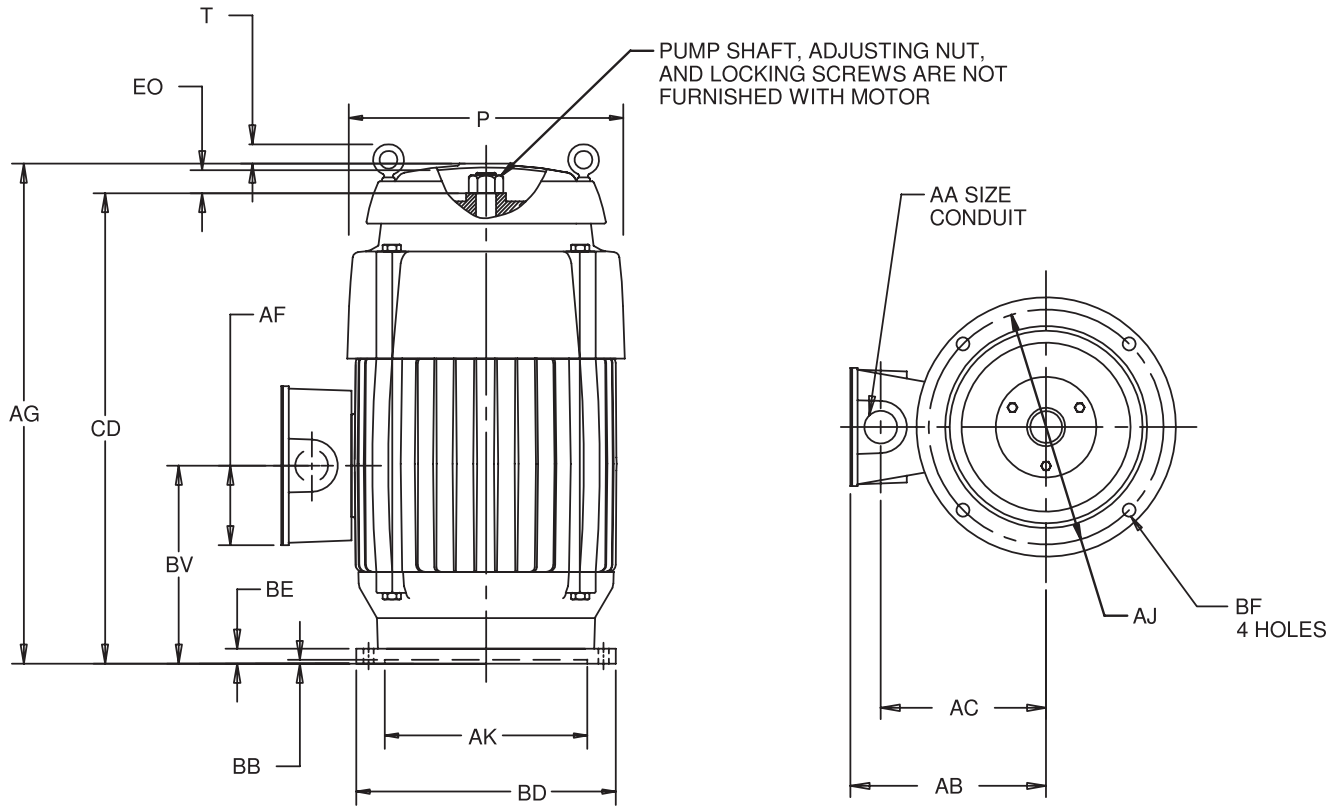

ALL DIMENSIONS ARE IN INCHES AND MILLIMETERS

UNITS	P <sup>2</sup>	T	AA	AB	AC	AF	AG	AJ
IN	12.88	1.50	1.00	7.30	6.14	2.63	21.25	9.125
MM	327	38		185	156	69	540	231.78

UNITS	AK +.003	BB MIN	BD MAX	BE	BF	BV	CD	EO
IN	8.250	.19	10.00	.75	.44	8.00	17.56	3.34
MM	209.55	5	254	19	11	203	446	85

- 1: ALL ROUGH DIMENSIONS MAY VARY BY .25" DUE TO CASTING AND/OR FABRICATION VARIATIONS.
- 2: LARGEST MOTOR WIDTH.
- 3: CONDUIT OPENINGS MAY BE LOCATED IN STEPS OF 90 DEGREES REGARDLESS OF LOCATION. STANDARD AS SHOWN WITH CONDUIT OPENING DOWN.
- 4: TOLERANCES SHOWN ARE IN INCHES ONLY.

TOLERANCES	
FACE RUNOUT	.004 T.I.R.
PERMISSIBLE ECCENTRICITY OF MOUNTING RABBIT	.004 T.I.R.



# Dimension Prints

## HOLLOSHAFT® Motors, Weather Protected Type I (AU), Frame 213 & 215TP

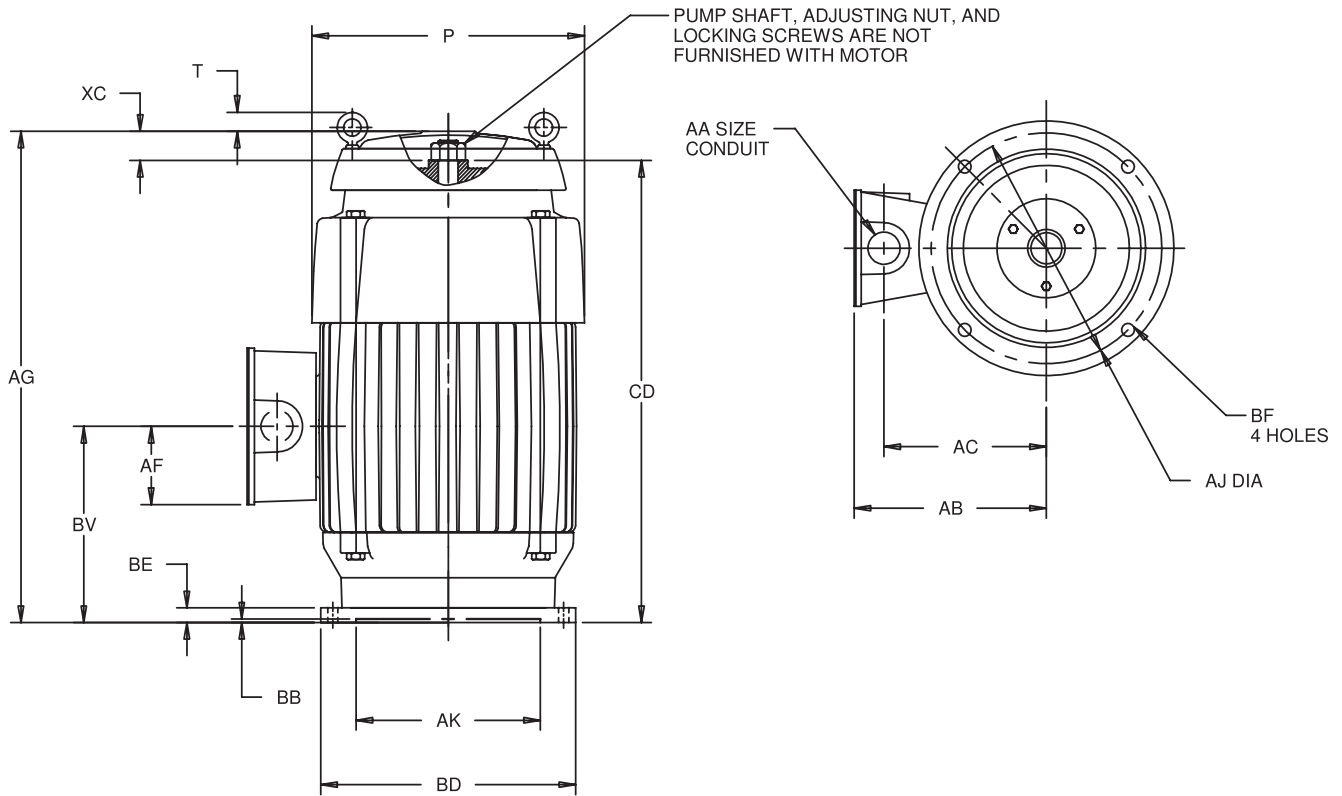

ALL DIMENSIONS ARE IN INCHES AND MILLIMETERS

UNITS	P <sup>2</sup>	T	AA	AB	AC	AF	AG	AJ	AK -.003
IN	12.88	1.50	1.00	7.88	6.63	3.19	21.25	9.125	8.250
MM	327	38		200	168	81	540	231.78	209.55

UNITS	BB MIN	BD MAX	BE	BF	BV	CD	XC
IN	0.25	10.00	0.94	0.44	8.00	17.56	3.34
MM	6	254	24	11	203	446	85

1. ALL ROUGH DIMENSIONS MAY VARY BY .25" DUE TO CASTING AND/OR FABRICATION VARIATIONS.
2. LARGEST MOTOR WIDTH.
3. CONDUIT OPENINGS MAY BE LOCATED IN STEPS OF 90 DEGREES REGARDLESS OF LOCATION. STANDARD AS SHOWN WITH CONDUIT OPENING DOWN.
4. TOLERANCES SHOWN ARE IN INCHES ONLY.

TOLERANCES	
FACE RUNOUT	.004 T.I.R.
PERMISSIBLE ECCENTRICITY OF MOUNTING RABBET	.004 T.I.R.



# Dimension Prints

## Three Phase HOLLOSHAFT® Motors, Weather Protected Type I (AU), Frame 254 Thru 256 TP

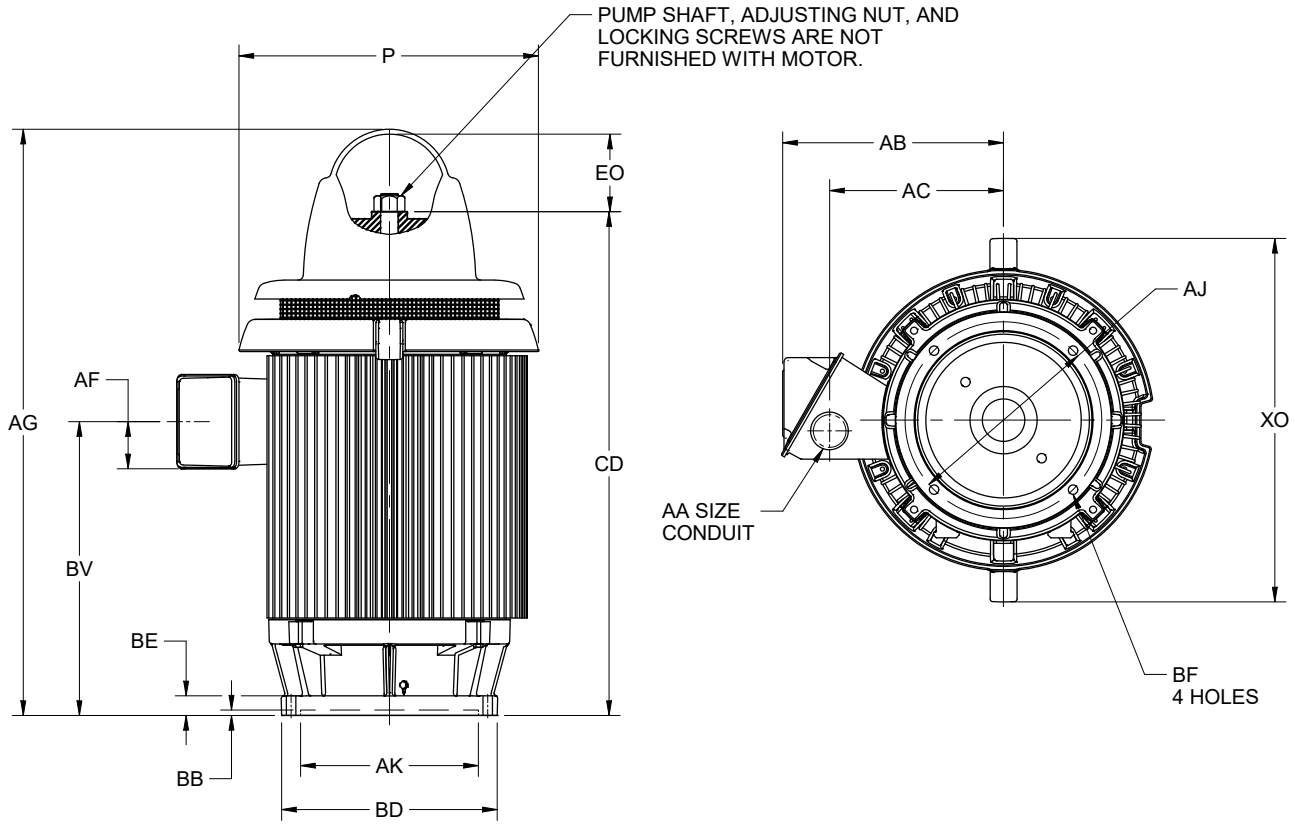

ALL DIMENSIONS ARE IN INCHES AND MILLIMETERS

UNITS	P <sup>2</sup>	AA	AB	AC	AF	AG <sup>5</sup>	BB MIN	BE	BV	CD <sup>5</sup>	EO	XO
IN	14.00	1.25	10.25	7.88	2.03	26.75	.25	.94	11.50	23.38	3.25	16.88
MM	356		260	200	52	679	6	24	292	594	83	429

FRAME	UNITS	AJ	AK	BD MAX	BF
254, 256TP	IN	9.125	8.250	10.00	.44
	MM	231.78	209.55	254	11
254, 256TPA	IN	14.750	13.500	16.50	.69
	MM	374.65	342.90	419	18
254, 256TPH	IN	9.125	8.250	12.00	.44
	MM	231.78	209.55	305	11

TOLERANCES	8.250 AK	13.500 AK
FACE RUNOUT	.004 T.I.R.	.007 T.I.R.
PERMISSIBLE ECCENTRICITY OF MOUNTING RABBET	.004 T.I.R.	.007 T.I.R.
TOLERANCE ON AK-DIMENSION	+.003	+.005

1. ALL ROUGH DIMENSIONS MAY VARY BY .25" DUE TO CASTING AND/OR FABRICATION VARIATIONS.
2. LARGEST MOTOR WIDTH.
3. TOLERANCES SHOWN ARE IN INCHES ONLY.

4. CONDUIT OPENINGS MAY BE LOCATED IN STEPS OF 180 DEGREES REGARDLESS OF LOCATION. STANDARD AS SHOWN.
5. DIMENSIONS SHOWN ARE FOR ALL RATINGS EXCEPT 20 HP, 4 POLE, TYPE AUS AND AUI. FOR THIS RATING THE DIMENSIONS ARE: AG=28.13 (715 MM)  
CD=24.75 (629 MM)

† All marks shown within this document are properties of their respective owners.





# Dimension Prints

## Three Phase HOLLOWSHAFT® Motors, Weather Protected Type I (AU), Frame 284 & 286TP

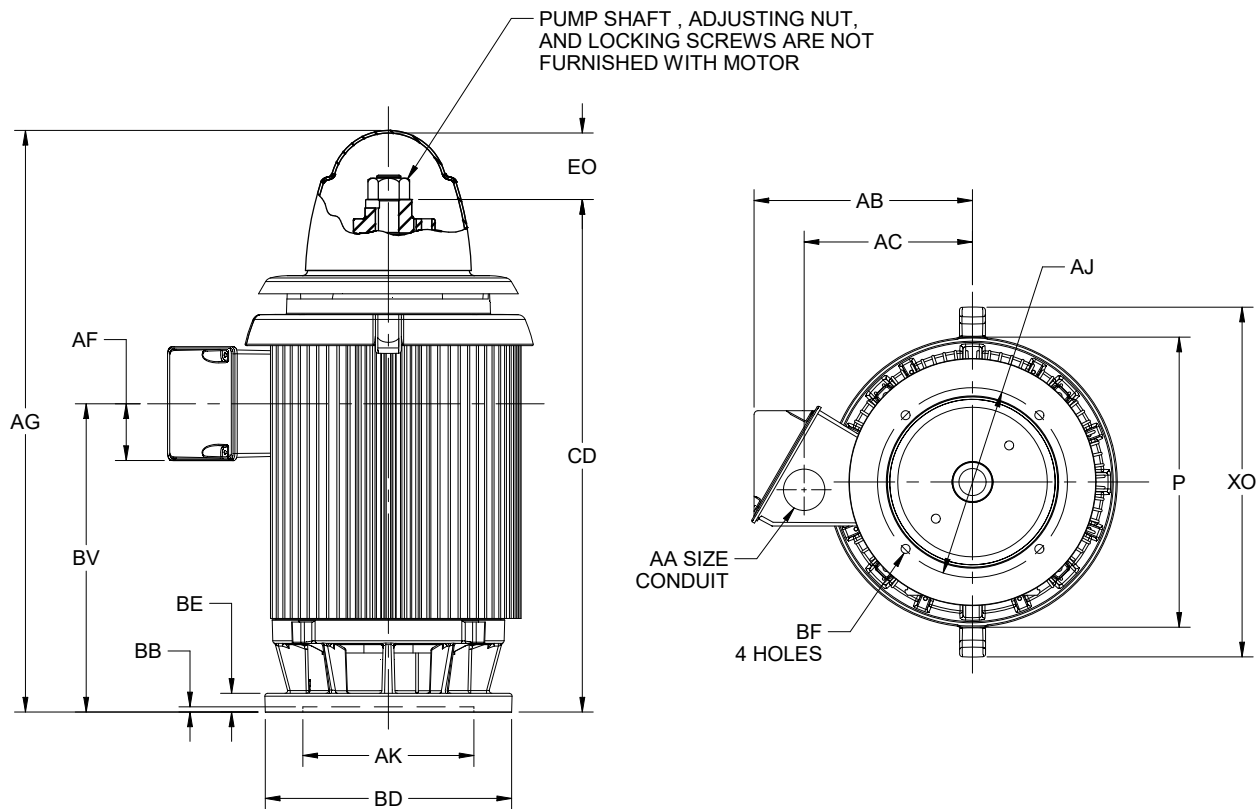

ALL DIMENSIONS ARE IN INCHES AND MILLIMETERS

UNITS	P <sup>2</sup>	AA	AB	AC	AF	AG	BE	BV	CD	EO	XO
IN	14.00	1.50	10.53	8.13	2.59	28.06	.91	15.29	24.86	3.19	16.88
MM	356		267	207	66	713	23	388	631	81	429

FRAME	UNITS	AJ	AK	BB MIN	BD MAX	BF
284, 286TP	IN	9.125	8.250	.25	10.00	.44
	MM	231.78	209.55	6	254	11
284, 286TPH	IN	14.750	13.500	.25	16.50	.69
	MM	374.65	342.90	6	419	18
284, 286TPA	IN	9.125	8.250	.25	12.00	.44
	MM	231.78	209.55	6	305	11

TOLERANCES	8.250 AK	13.500 AK
FACE RUNOUT	.004 T.I.R.	.007 T.I.R.
PERMISSIBLE ECCENTRICITY OF MOUNTING RABBET	.004 T.I.R.	.007 T.I.R.
TOLERANCE ON AK-DIMENSION	+.003	+.005

1. DIMENSIONS MAY VARY BY .25" DUE TO CASTING AND/OR FABRICATION VARIATIONS.
2. LARGEST MOTOR WIDTH.
3. TOLERANCES SHOWN ARE IN INCHES ONLY.
4. CONDUIT BOX MAY BE LOCATED IN STEPS OF 180° REGARDLESS OF LOCATION. STANDARD AS SHOWN WITH CONDUIT OPENING DOWN.
5. FRAME REFERENCE 13.625" / 284/286.

6. DIMENSIONS SHOWN ARE FOR ALL RATINGS EXCEPT 20 HP, 6 POLE, TYPE AUS AND AUI. FOR THIS RATING THE DIMENSIONS ARE:  
 AG=29.19 (741 MM)  
 CD=25.88 (657 MM)

† All marks shown within this document are properties of their respective owners.

Revised — April 2019



# Dimension Prints

## HOLLOSHAFT® Motors, Weather Protected Type I (RU), Frame 324 & 326TP

PUMP SHAFT, ADJUSTING NUT AND LOCKING SCREWS ARE NOT FURNISHED WITH MOTOR

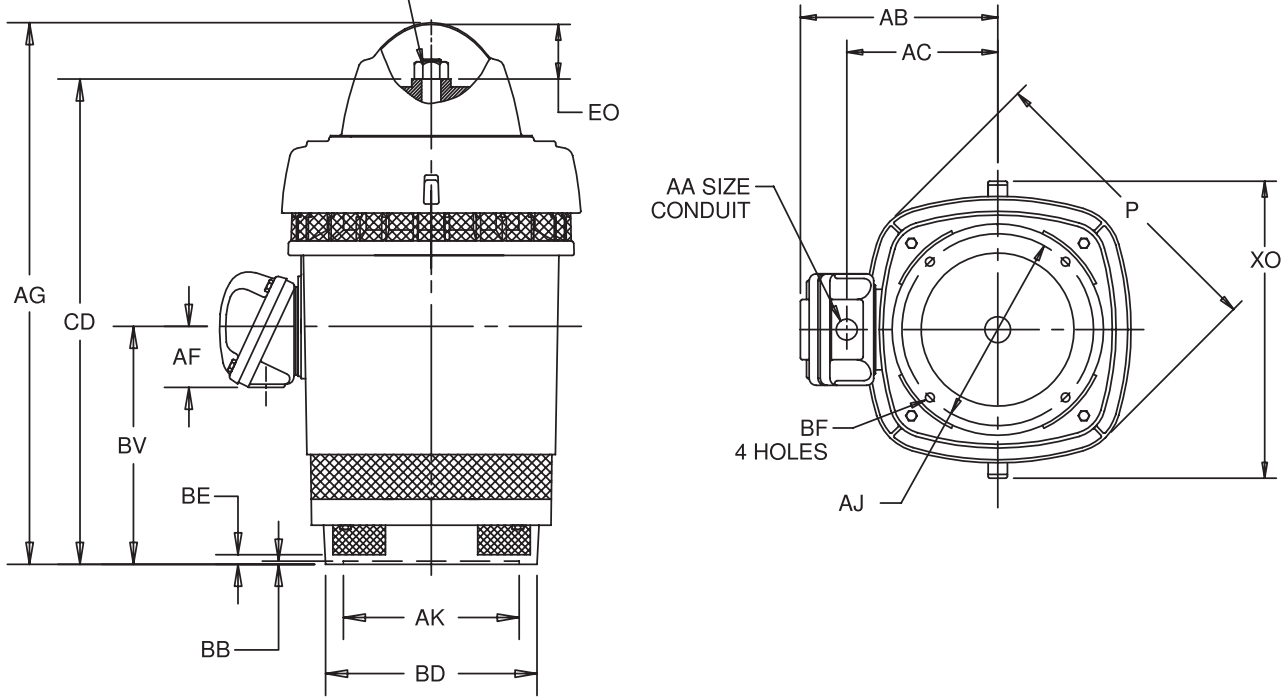

ALL DIMENSIONS ARE IN INCHES AND MILLIMETERS

UNITS	P <sup>2</sup>	AG	BE	BV	CD	EO	XO
IN	19.06	33.06	.69	11.06	28.22	4.69	21.69
MM	484	840	18	281	717	119	551

FRAME	UNITS	AJ	AK	BB MIN	BD MAX	BF
324, 326TP	IN	14.750	13.500	.25	16.50	.69
	MM	374.65	342.90	6	419	18
324,326TPH	IN	9.125	8.250	.19	12.00	.44
	MM	231.78	209.55	5	305	11

CONDUIT BOX MATERIAL	UNITS	AA	AB	AC	AF
STEEL	IN	3.00	15.84	11.56	3.38
	MM		402	294	86
CAST IRON	IN	3 NPT	16.63	12.25	4.63
	MM		422	311	118

- 1: ALL ROUGH DIMENSIONS MAY VARY BY .25" DUE TO CASTING AND/OR FABRICATION VARIATIONS.
- 2: LARGEST MOTOR WIDTH.
- 3: CONDUIT OPENINGS MAY BE LOCATED IN STEPS OF 90 DEGREES REGARDLESS OF LOCATION. STANDARD AS SHOWN WITH CONDUIT OPENING DOWN.
- 4: TOLERANCES SHOWN ARE IN INCHES ONLY.

TOLERANCES	8.250 AK	13.500 AK
FACE RUNOUT	.004 T.I.R.	.007 T.I.R.
PERMISSIBLE ECCENTRICITY OF MOUNTING RABBET	.004 T.I.R.	.007 T.I.R.
TOLERANCE ON AK DIMENSION	+.003	+.005



# Dimension Prints

## Three Phase HOLLOWSHAFT® Motors, Weather Protected Type I (RU), Frame 364 & 365TP

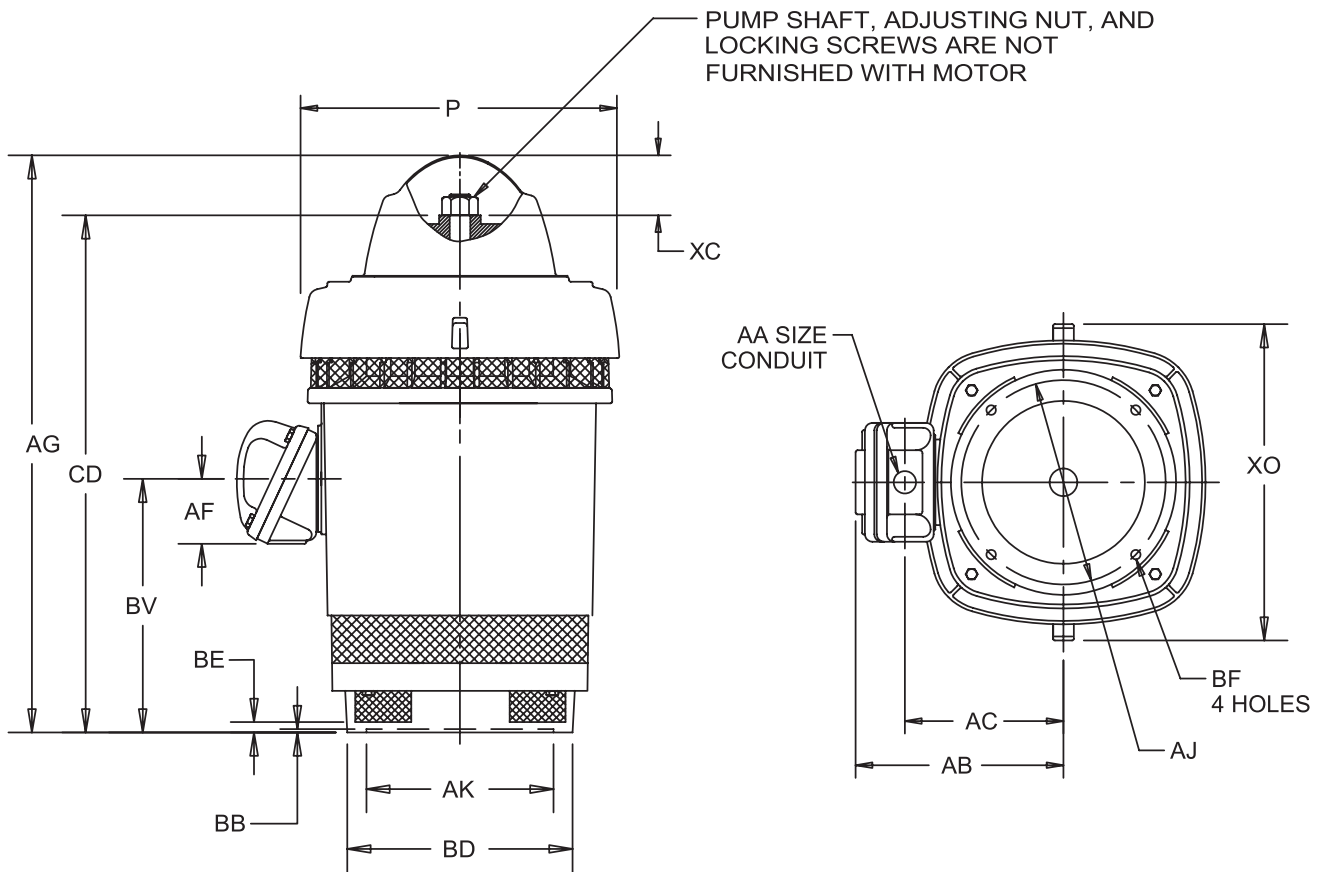

ALL DIMENSIONS ARE IN INCHES AND MILLIMETERS

BASIC FRAME	UNITS	P <sup>2</sup>	AG	BE	BV	CD	XC	XO
360	IN	19.06	36.00	.69	14.00	31.16	4.69	21.69
	MM	484	914	18	356	791	119	551

FRAME	CONDUIT BOX MATERIAL	UNITS	AA	AB	AC	AF
360	STEEL	IN	3.00	15.84	11.56	3.38
		MM	76	402	294	86
	CAST IRON	IN	3 NPT	16.63	12.25	4.63
		MM		422	311	118

FRAME	UNITS	AJ	AK	BB MIN	BD MAX	BF
364, 365TP	IN	14.750	13.500	.25	16.50	.69
	MM	374.65	342.90	6	419	18
364, 365TPA	IN	9.125	8.250	.19	12.00	.44
	MM	231.78	209.55	5	305	11

- 1: ALL ROUGH DIMENSIONS MAY VARY BY .25" DUE TO CASTING VARIATIONS.
- 2: LARGEST MOTOR WIDTH.
- 3: CONDUIT BOX OPENING MAY BE LOCATED IN STEPS OF 90° REGARDLESS OF LOCATION. STANDARD AS SHOWN WITH CONDUIT OPENING DOWN.
- 4: TOLERANCES SHOWN ARE IN INCHES ONLY.

TOLERANCES	8.250 AK	13.500 AK
"AK" DIMENSION	+ .003; - .000	+ .005; - .000
FACE RUNOUT	.004 T.I.R.	.007 T.I.R.
PERMISSIBLE ECCENTRICITY OF MOUNTING RABBET	.004 T.I.R.	.007 T.I.R.



# Dimension Prints

## HOLLOSHAFT® Motors, Weather Protected Type I (RU), Frame 404 & 405TP

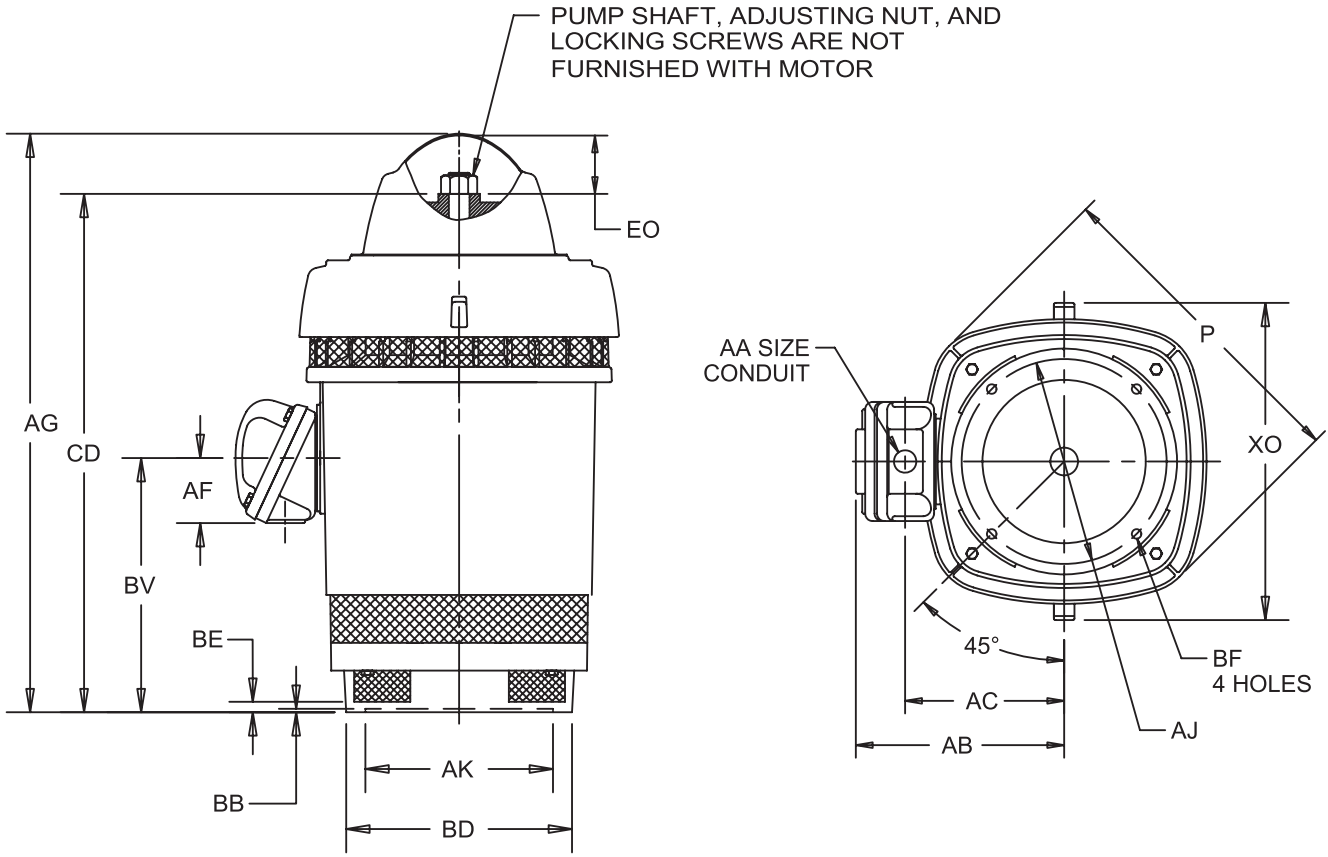

DIMENSIONS ARE IN INCHES AND MILLIMETERS

UNITS	P <sup>2</sup>	AG	AJ	AK +.005	BB MIN	BE	BF	BV	CD	EO	XO
IN	23.75	42.69	14.750	13.500	.25	.75	.69	18.13	36.94	5.50	24.13
MM	603	1084	374.65	342.90	6	19	18	461	938	140	613

FRAME	CONDUIT BOX MATERIAL	UNITS	AA	AB	AC	AF
400	STEEL	IN	3.00	16.97	12.69	3.38
		MM		431	322	86
	CAST IRON	IN	3 NPT	17.75	13.38	4.63
		MM		451	340	118

FRAME	UNITS	BD MAX
404, 405TP	IN	16.50
	MM	419
404, 405TPA	IN	20.00
	MM	508

- 1: ALL ROUGH DIMENSIONS MAY VARY BY .25" DUE TO CASTING AND/OR FABRICATION VARIATIONS.
- 2: LARGEST MOTOR WIDTH.
- 3: TOLERANCES SHOWN ARE IN INCHES ONLY.
- 4: CONDUIT BOX OPENING MAY BE LOCATED IN STEPS OF 90° REGARDLESS OF LOCATION. STANDARD AS SHOWN WITH CONDUIT OPENING DOWN.

TOLERANCES	
FACE RUNOUT	.007 T.I.R.
PERMISSIBLE ECCENTRICITY OF MOUNTING RABBET	.007 T.I.R.

† All marks shown within this document are properties of their respective owners.

Revised — April 2019



# Dimension Prints

## HOLLOSHAFT® Motors, Weather Protected Type I (RU), Frame H444 & H445TP

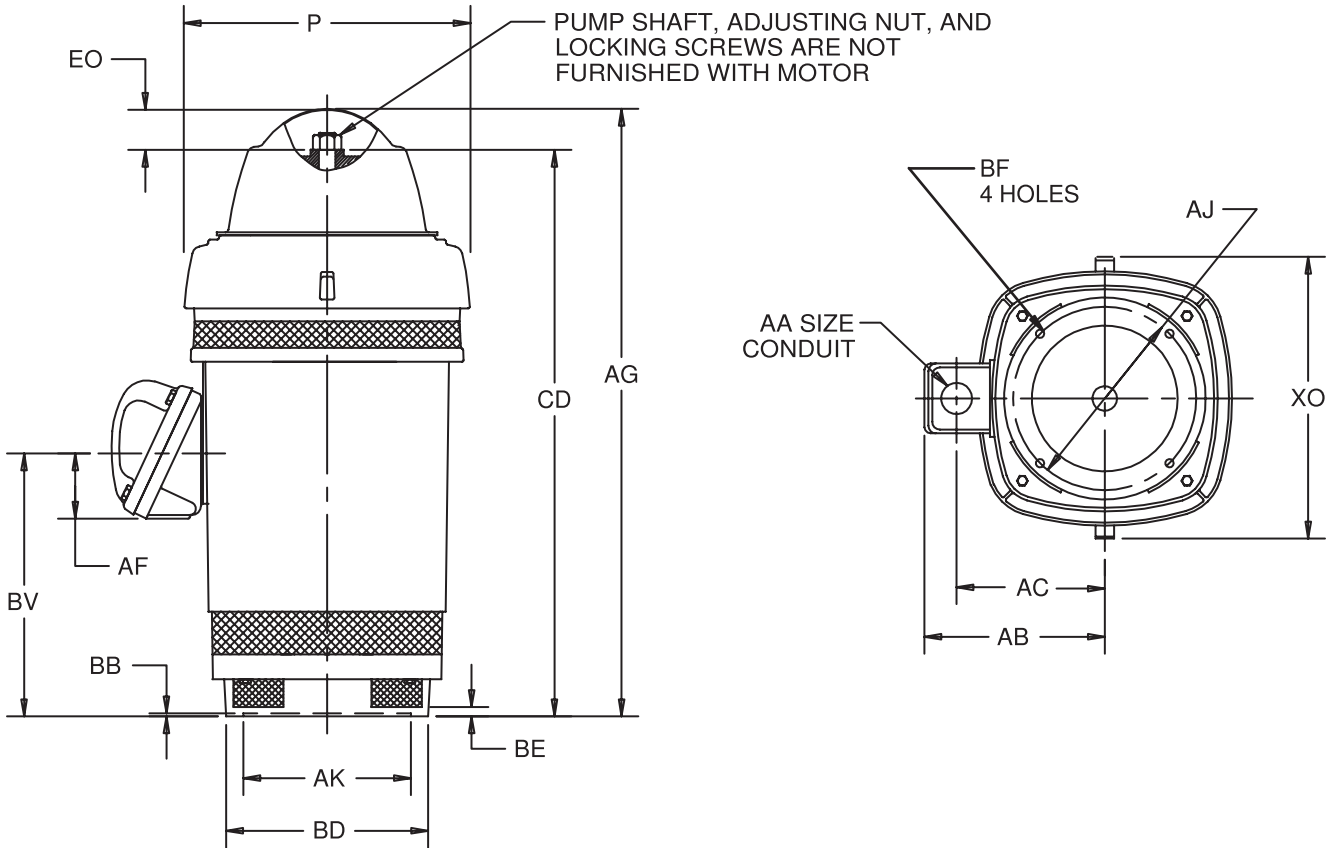

ALL DIMENSIONS ARE IN INCHES AND MILLIMETERS

UNITS	P <sup>2</sup>	AG	AJ	AK +.005	BB MIN	BE	BF	BV	CD	EO	XO
IN	23.38	50.06	14.750	13.500	.25	.75	.69	21.19	44.78	5.13	27.50
MM	594	1272	374.65	342.90	6	19	18	538	1137	130	699

CONDUIT BOX MATERIAL	UNITS	AA	AB	AC	AF
STEEL	IN	3.00	18.94	14.44	4.72
	MM		481	367	120
CAST IRON	IN	3 1/2 NPT	18.56	14.31	5.28
	MM		471	363	134

FRAME	UNITS	BD MAX
H444, H445TP	IN	16.50
	MM	419
H444, H445TPA	IN	20.00
	MM	508

TOLERANCES	
FACE RUNOUT	.007 T.I.R.
PERMISSIBLE ECCENTRICITY OF MOUNTING RABBET	.007 T.I.R.

- 1: ALL ROUGH DIMENSIONS MAY VARY BY .25" DUE TO CASTING AND/OR FABRICATION VARIATIONS.
- 2: LARGEST MOTOR WIDTH.
- 3: CONDUIT OPENINGS MAY BE LOCATED IN STEPS OF 90 DEGREES REGARDLESS OF LOCATION. STANDARD AS SHOWN WITH CONDUIT OPENING DOWN.
- 4: TOLERANCES SHOWN ARE IN INCHES ONLY.



# Dimension Prints

## HOLLOSHAFT® Motors, Weather Protected Type I (RU), Frame 447TP

CONDUIT BOX FOR ACCESSORY LEADS AS REQUIRED

PUMP SHAFT, ADJUSTING NUT AND LOCKING SCREWS ARE NOT FURNISHED WITH MOTOR

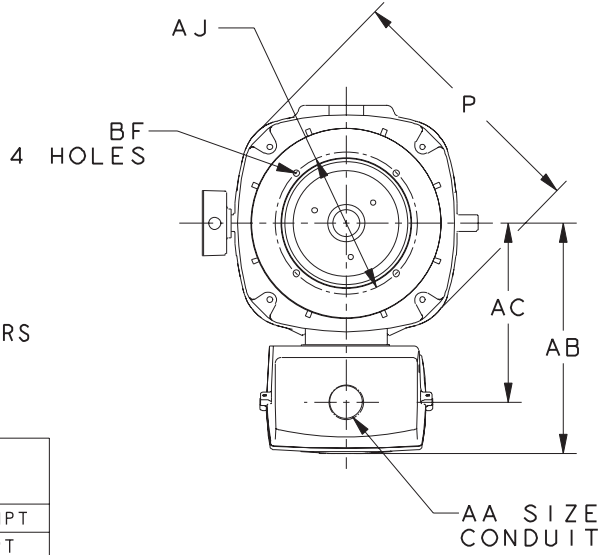
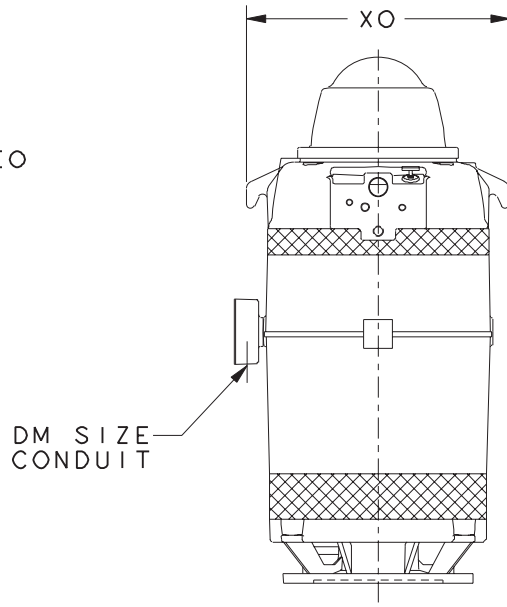
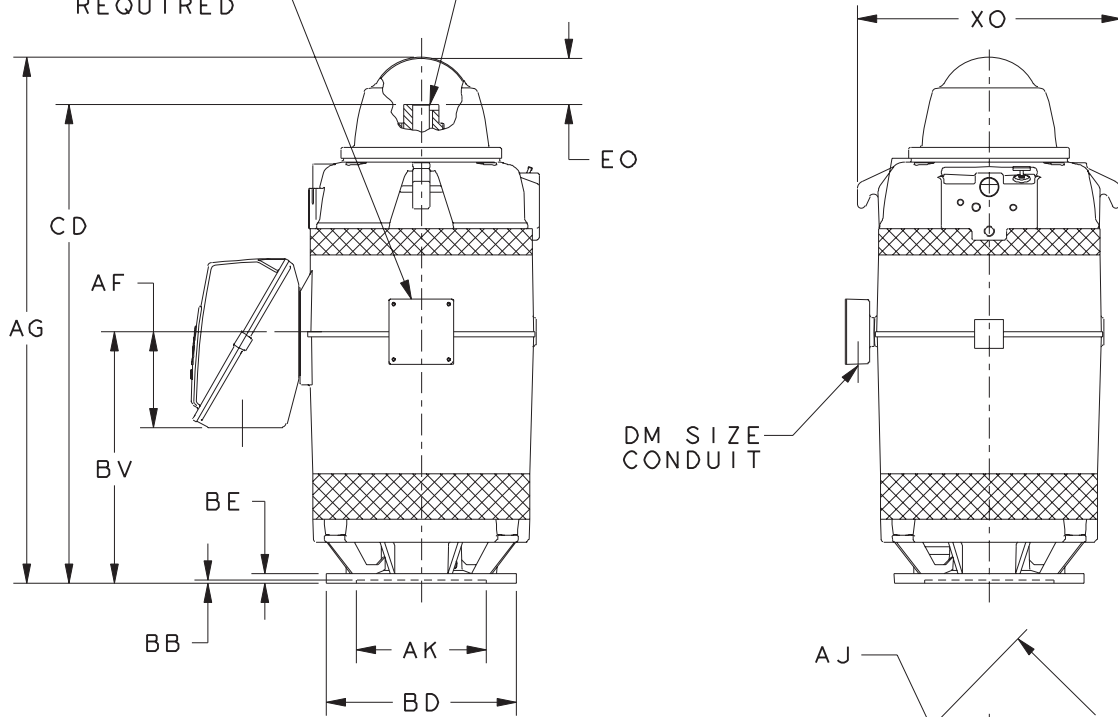

ALL DIMENSIONS ARE IN INCHES AND MILLIMETERS

FRAME	UNITS	BD MAX	AA	DM
447TP	IN	16.50	2 1/2 NPT	3/4 NPT
	MM	419		
447TPA	IN	20.00	3 NPT	1 NPT
	MM	508		
447TPB	IN	24.50	3 1/2 NPT	1 1/2 NPT
	MM	622		

UNITS	P 2	AB	AC	AF	AG	AJ
IN	26.94	24.25	18.75	10.00	55.00	14.750
MM	684	616	476	254	1397	374.65

UNITS	AK +.005	BB MIN	BE	BF	BV	CD	EO	XO
IN	13.500	.25	1.00	.69	26.19	49.78	5.13	27.50
MM	342.90	6	25	18	665	1264	130	699

1: DIMENSIONS MAY VARY .25" DUE TO CASTING AND/OR FABRICATION VARIATIONS.  
 2: LARGEST MOTOR WIDTH.  
 3: TOLERANCES SHOWN ARE IN INCHES ONLY.



# Dimension Prints

## HOLLOSHAFT® Motors, Weather Protected Type I (RU), Frame 449TPH, TP, TPA

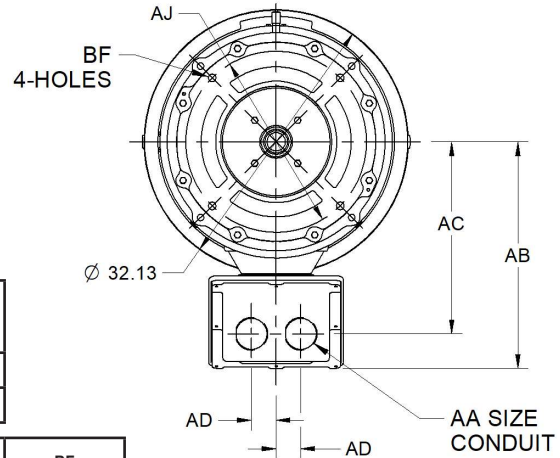
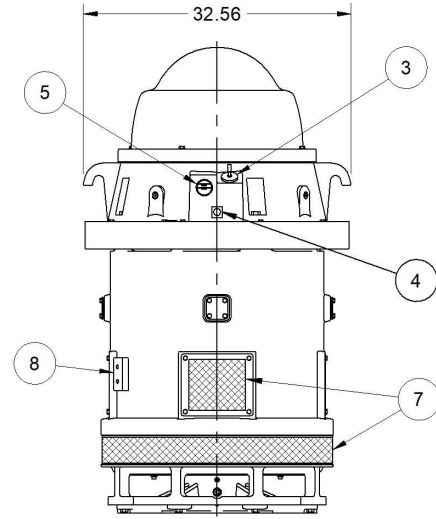
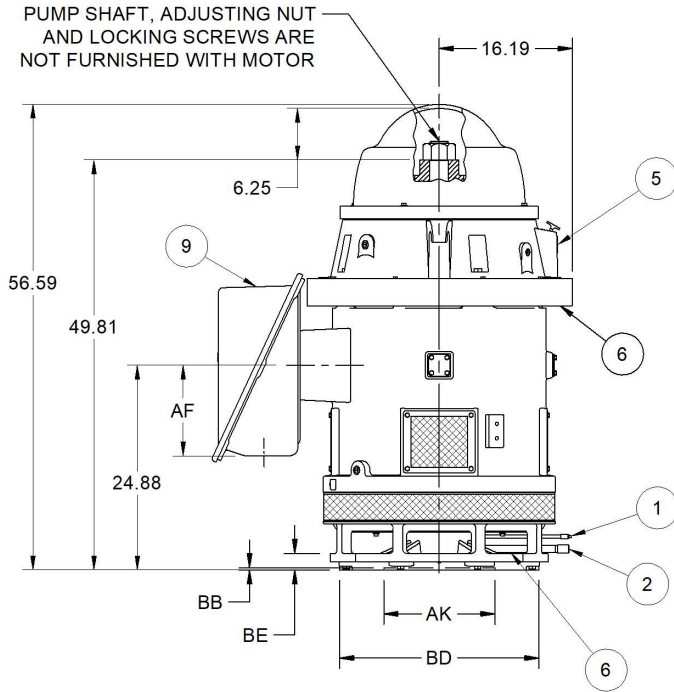

ALL DIMENSIONS ARE IN INCHES

C/BOX VOLUME (CU. IN.)	QTY OF CONDUIT HOLES	AB	AC	AD	AF
2000	2	26.36	19.75	3.00	15.50
3400	2	31.13	19.75	3.00	15.50

FRAME	AJ	AK +.005	BB MIN	BD MAX	BE	BF
449PH	14.75	13.500	.25	20.00	2.00	.688
10 449P	14.75	13.500		24.50		.938
	22.00			30.50		.813
449PA	32.00	22.000				

### FEATURE LISTING

1	LOWER GREASE FILL	6	AIR INTAKE, 360° AROUND
2	LOWER GREASE DRAIN	7	AIR EXHAUST, 360° AROUND
3	UPPER SUMP OIL FILL	8	GRD PADS, DIAG OPP. 1/2-13
4	UPPER SUMP OIL DRAIN	9	MAIN CONDUIT BOX
5	UPPER SUMP SIGHT WINDOW	10	449P HAS TWO BOLT CIRCLES

- ALL ROUGH CASTING DIMENSIONS MAY VARY BY .25" DUE TO CASTING VARIATIONS.
- LARGEST MOTOR WIDTH.
- CONDUIT OPENING MAY BE LOCATED IN STEPS OF 90°. STANDARD AS SHOWN WITH CONDUIT OPENING DOWN.

TOLERANCES	
FACE RUNOUT	.007 T.I.R.
PERMISSIBLE ECCENTRICITY OF MOUNTING RABBET	.007 T.I.R.
NON-MACHINED DIMENSIONS MAY VARY BY ±.25	





# Dimension Prints

## HOLLOSHAFT® Motors, Weather Protected Type I (RU), Frame 5000PH

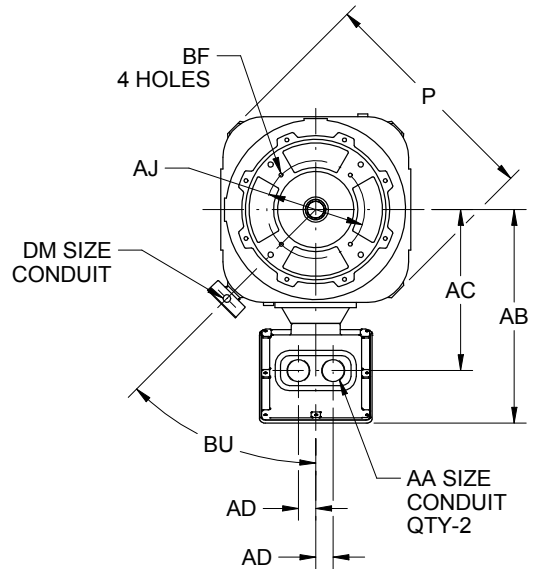
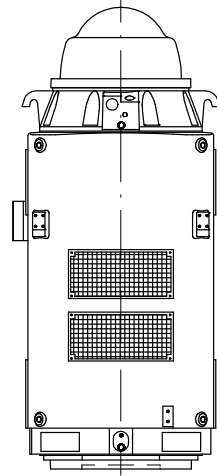
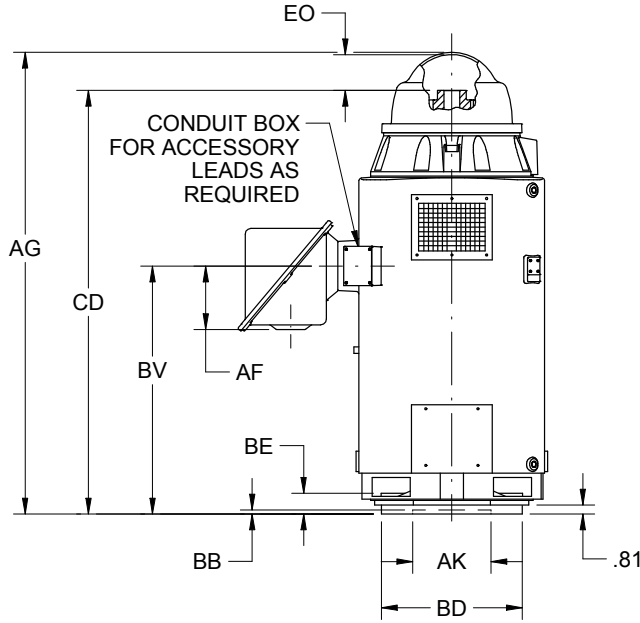

TOLERANCES	
FACE RUNOUT	.007 T.I.R.
PERMISSIBLE ECCENTRICITY OF MOUNTING RABBET	.007 T.I.R.
MAXIMUM SHAFT END PLAY	.010

FRAME	P	AG	BV	CD	EO
5008	40.00	63.88	27.00	57.06	6.42
5012		78.88	42.00	72.30	

FRAME	AJ	AK +.005	BB MIN	BD MAX	BE	BF
5000PH	14.750	13.500	.25	20.00	2.19	.69
5000P <sup>3</sup>	14.750	13.500		24.50		.69
	22.000	30.50		.81		
5000PA	26.000	22.000				

VOLTS	C/BOX VOLUME (CU.IN.)	AB	AC	AD	AF	BU
0-4800	3400	36.50	27.88	3.00	10.94	45°

AA	DM
2 NPT	1/2 NPT
2 1/2 NPT	3/4 NPT
3 NPT	1 NPT
3 1/2 NPT	1 1/4 NPT
4 NPT	1 1/2 NPT

1. DIMENSIONS MAY VARY .25" DUE TO CASTING AND/OR FABRICATION VARIATIONS.
2. DIMENSIONS AND TOLERANCES ARE SHOWN IN INCHES.
3. 5000P HAS TWO BOLT CIRCLES.



# Dimension Prints

## HOLLOSHAFT® Motors, Totally Enclosed Fan Cooled (TU, TUC), Frame 182 – H215TP

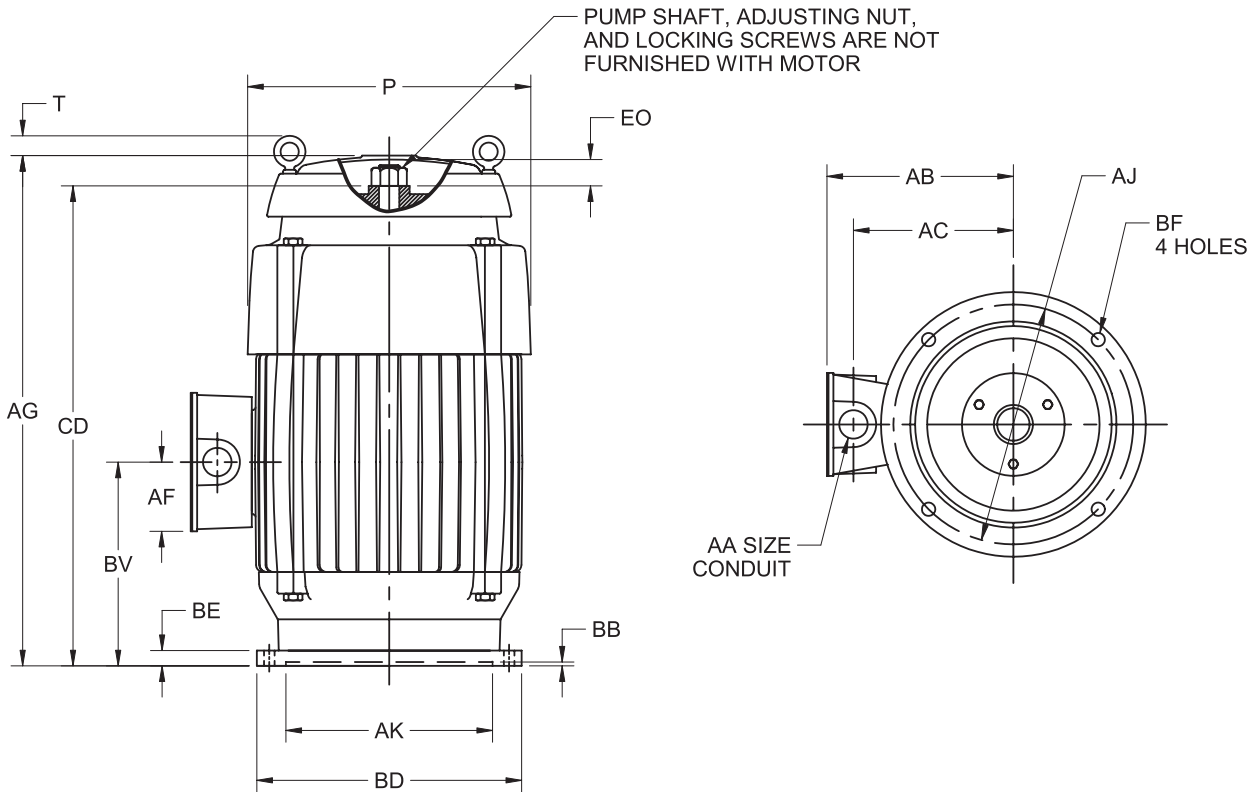

ALL DIMENSIONS ARE IN INCHES AND MILLIMETERS

UNITS	TYPE	FRAME	P <sup>2</sup>	T	AA	AB	AC	AF	AG	AJ	AK +.003	BB MIN	BD MAX	BE
IN	TUS	180/210	12.88	1.47	1	7.66	6.5	3.19	21.5	9.125	8.25	0.19	10	0.75
MM	TUS	180/210	327	37		195	165	84	546	231.78	209.55	5	254	19
IN	TUS	H210	12.88	1.47	1	7.66	6.5	3.19	22.46	9.125	8.25	0.19	10	0.75
MM	TUS	H210	327	37		195	165	81	570	231.78	209.55	5	254	19
IN	TUCI	180/210	10.81	1.63	1	9.81	7.25	2.00	21.13	9.125	8.25	0.22	10	0.75
MM	TUCI	180/210	275	41		249	184	51	537	231.78	209.55	6	254	0.19

UNITS	TYPE	FRAME	BF	BV	CD	EO
IN	TUS	180/210	0.44	8.38	17.56	3
MM	TUS	180/210	11	213	446	76
IN	TUS	H210	0.44	8.38	18.81	3
MM	TUS	H210	11	213	447.77	76
IN	TUCI	180/210	0.44	8.00	17.50	3.31
MM	TUCI	180/210	11	203	445	84

TOLERANCES	
FACE RUNOUT PERMISSIBLE ECCENTRICITY	.004 T.I.R.
OF MOUNTING RABBET	.004 T.I.R.

1. ALL ROUGH DIMENSIONS MAY VARY BY .25 IN DUE TO CASTING AND/OR FABRICATION VARIATIONS.
2. LARGEST MOTOR WIDTH.
3. CONDUIT OPENINGS MAY BE LOCATED IN STEPS OF 90 DEGREES REGARDLESS OF LOCATION.  
STANDARD AS SHOWN WITH CONDUIT OPENING DOWN.
4. TOLERANCES SHOWN ARE IN INCHES ONLY.



# Dimension Prints

## HOLLOSHAFT® Motors, Totally Enclosed Fan Cooled (TU, TUC), Frame 254 & 256TP

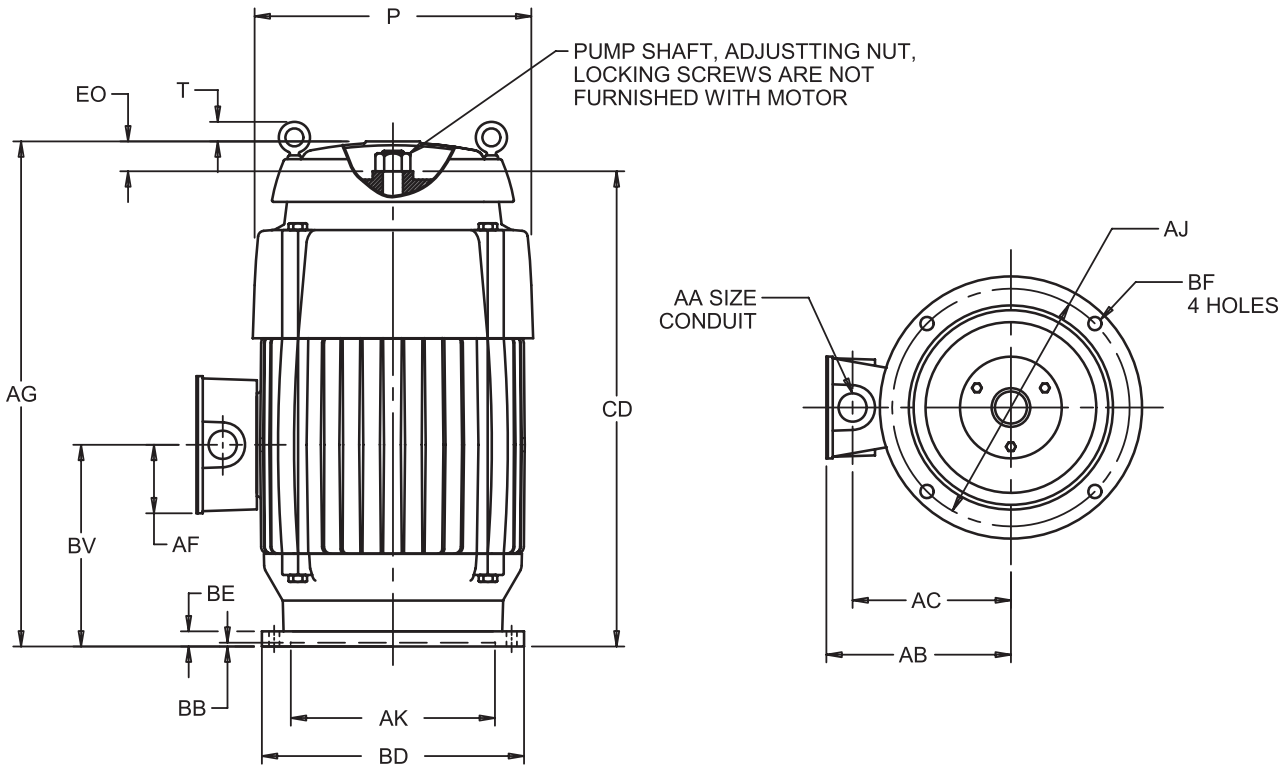

ALL DIMENSIONS ARE IN INCHES AND MILLIMETERS

UNITS	TYPE	P <sup>2</sup>	T	AA	AB	AC	AF	AG	AJ	AK +.003	BB MIN	BE
IN	TUS	14.44	1.13	1.25	10.25	7.88	3.63	26.25	9.125	8.25	0.19	1.00
MM	TUS	367	29		260	200	92	92	231.78	209.55	5	25
IN	TUCI	13.81	-1.00	1.25	11.53	8.53	2.63	28.63	9.125	8.25	0.19	0.59
MM	TUCI	351	-25		293	217	67	727	231.78	209.55	5	15

UNITS	TYPE	BF	BV	CD	EO
IN	TUS	0.44	10.50	22.94	2.94
MM	TUS	11	268	583	75
IN	TUCI	0.44	10.00	22.94	5.50
MM	TUCI	11	254	583	140

UNITS	FRAME	TYPE	BD MAX
IN	254, 256TP	TUS, TUCI	10.00
MM		TUS, TUCI	254
IN	254, 256TPH	TUS, TUCI	12.00
MM		TUS, TUCI	305

- 1: ALL ROUGH DIMENSIONS MAY VARY BY .25" DUE TO CASTING AND/OR FABRICATION VARIATIONS.
- 2: LARGEST MOTOR WIDTH.
- 3: CONDUIT OPENINGS MAY BE LOCATED IN STEPS OF 90 DEGREES REGARDLESS OF LOCATION. STANDARD AS SHOWN WITH CONDUIT OPENING DOWN.
- 4: TOLERANCES SHOWN ARE IN INCHES ONLY.

TOLERANCES	
FACE RUNOUT	.004 T.I.R.
PERMISSIBLE ECCENTRICITY OF MOUNTING RABBET	.004 T.I.R.

† All marks shown within this document are properties of their respective owners.



# Dimension Prints

## HOLLOSHAFT® Motors, Totally Enclosed Fan Cooled (TU, TUC), Frame 284 & 286TP

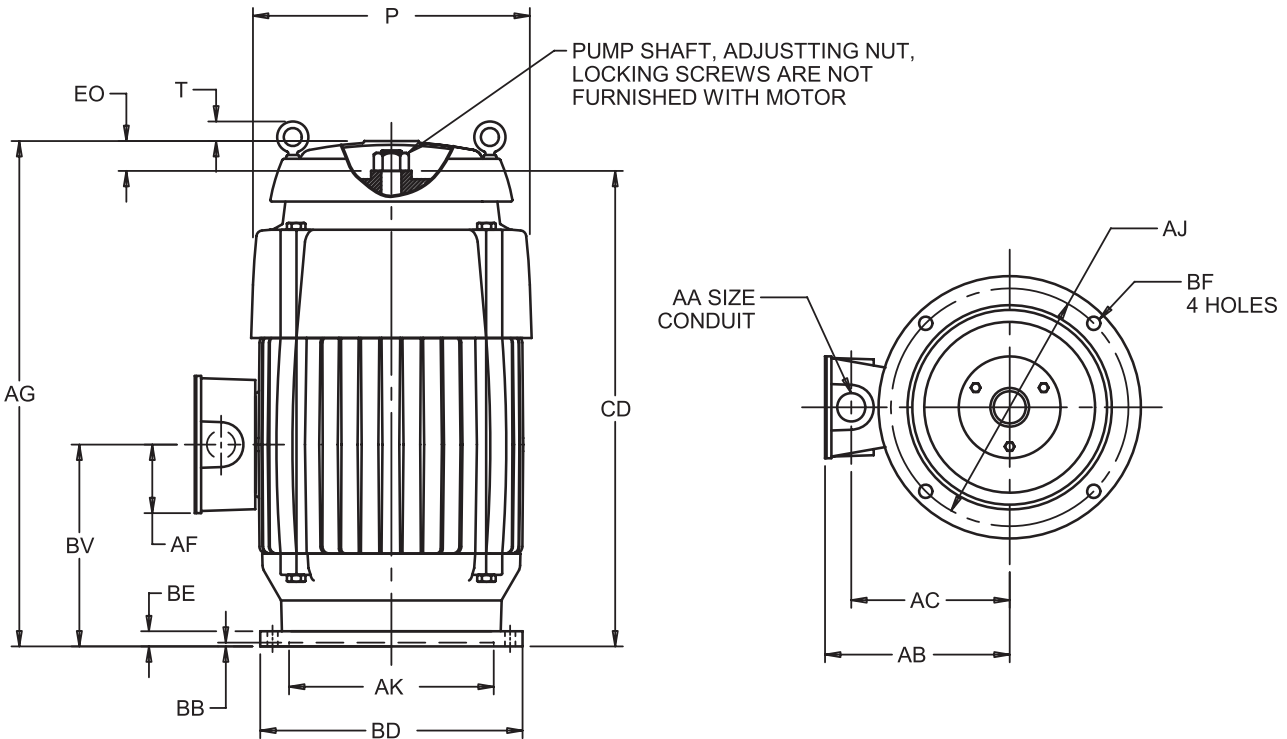

ALL DIMENSIONS ARE IN INCHES AND MILLIMETERS

UNITS	TYPE	P <sup>2</sup>	T	AA	AB	AC	AF	AG	BE	BV	EO
IN	TUS	14.44	1.13	1.5	11.09	8.32	4.44	29.88	1.00	13.44	2.94
MM	TUS	367	29		282	211	113	759	25	341	75
IN	TUCI	14.75	-1.31	2	13.19	9.69	3.88	32.63	0.91	11.19	5.88
MM	TUCI	375	-33		335	246	99	829	23	284	149

UNITS	FRAME	AJ	AK +.003	BB MIN	BF	CD
IN	284, 286TP	9.125	8.250	0.19	0.44	26.56
MM		231.78	209.55	5	11	675
IN	284, 286TPA	9.125	8.250	0.19	0.44	26.56
MM		231.78	209.55	5	11	675
IN	284, 286TPH	14.75	13.50	0.25	0.69	26.56
MM		374.65	342.90	6	18	675

UNITS	FRAME	TYPE	BD MAX
IN	284, 286TP	TUS, TUCI	10.00
MM		TUS, TUCI	254
IN	284, 286TPA	TUS, TUCI	12.00
MM		TUS, TUCI	305
IN	284, 286TPH	TUS, TUCI	16.50
MM		TUS, TUCI	419

- 1: ALL ROUGH DIMENSIONS MAY VARY BY .25" DUE TO CASTING AND/OR FABRICATION VARIATIONS.
- 2: LARGEST MOTOR WIDTH.
- 3: CONDUIT OPENINGS MAY BE LOCATED IN STEPS OF 90 DEGREES REGARDLESS OF LOCATION. STANDARD AS SHOWN WITH CONDUIT OPENING DOWN.
- 4: TOLERANCES SHOWN ARE IN INCHES ONLY.

TOLERANCES	8.250 AK	13.500 AK
"AK" DIMENSION	-.000;+.003	-.000;+.005
FACE RUNOUT	.004 T.I.R.	.007 T.I.R.
PERMISSIBLE ECCENTRICITY OF MOUNTING RABBET	.004 T.I.R.	.007 T.I.R.



# Dimension Prints

## HOLLOSHAFT® Motors, Totally Enclosed Fan Cooled (TU, TUC), Frame 324 & 326TP

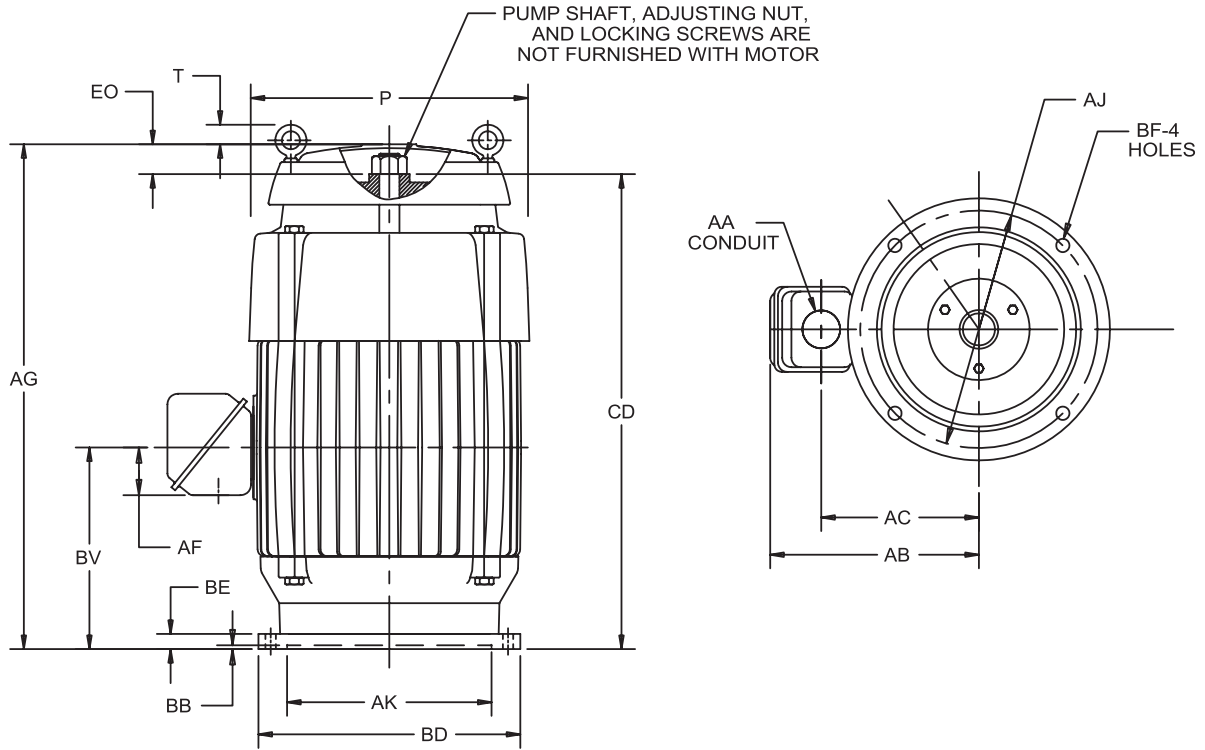

ALL DIMENSIONS ARE IN INCHES & MILLIMETERS

UNITS	P	T	AA	AB	AC	AF	AG	BE	BV	CD	EO
IN	17.00	-1.25	2.00	14.13	10.75	3.25	35.63	1.00	11.94	28.50	6.88
MM	432	-32		359	273	83	905	25	303	724	175

FRAME	UNITS	AJ	AK	BB MIN	BD MAX	BF
324,326TP	IN	14.750	13.500	.25	16.50	.69
	MM	374.65	342.90	6	419	18
324,326TPH	IN	9.125	8.250	.19	12.00	.44
	MM	231.78	209.55	5	305	11

- 1: ALL ROUGH CASTING DIMENSIONS MAY VARY BY .25" DUE TO CASTING AND/OR FABRICATION VARIATIONS.
- 2: LARGEST MOTOR WIDTH.
- 3: CONDUIT BOX MAY BE LOCATED IN STEPS OF 90° STANDARD AS SHOWN WITH CONDUIT OPENING DOWN.
- 4: (-) MINUS SIGN INDICATES EYEBOLT IS BELOW THE TOP OF THE UNIT.
- 5: TOLERANCES SHOWN ARE IN INCHES ONLY.

TOLERANCES	8.250 AK	13.500 AK
FACE RUNOUT	.004 T.I.R.	.007 T.I.R.
PERMISSIBLE ECCENTRICITY OF MOUNTING RABBET	.004 T.I.R.	.007 T.I.R.
"AK" DIMENSION	-.000;+.003	-.000;+.005



# Dimension Prints

## Three Phase HOLLOSHAFT® Motors, Totally Enclosed Fan Cooled (TU, TUC), Frame 364 Thru 365

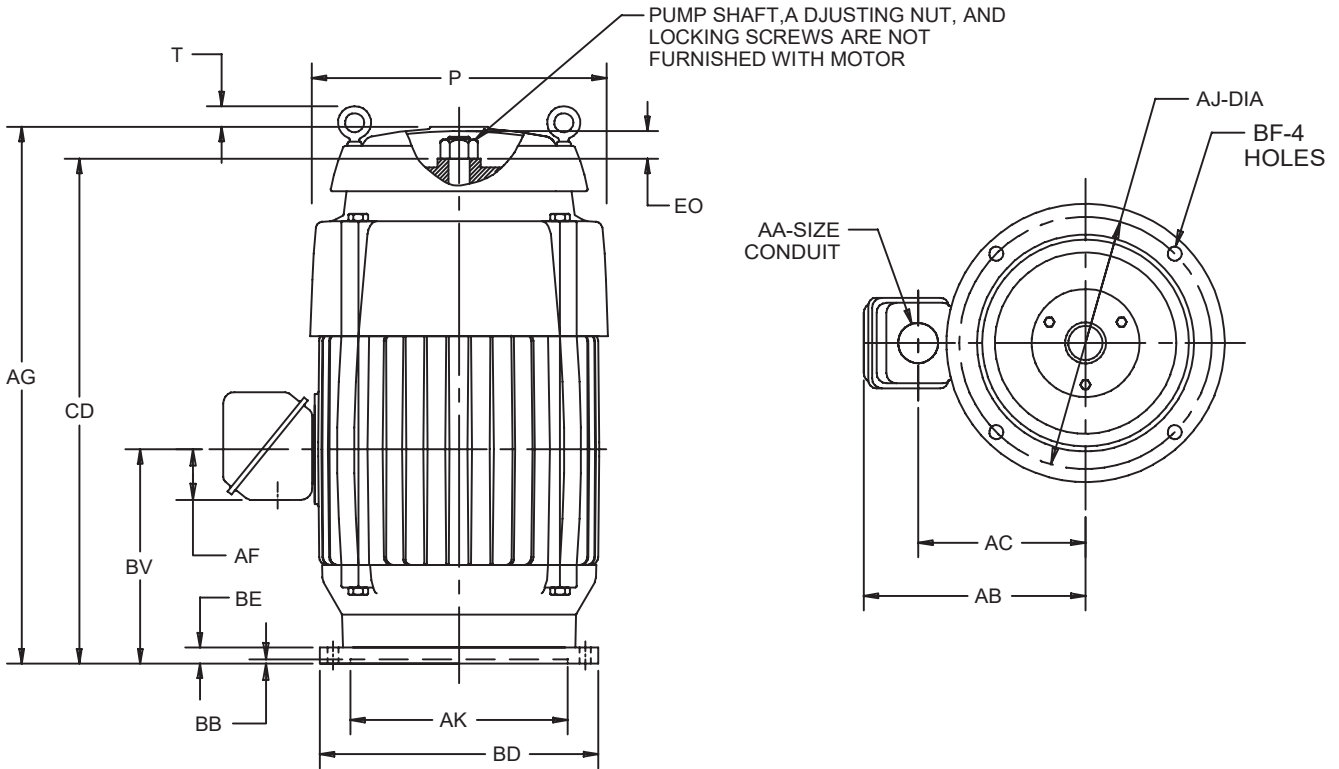

ALL DIMENSIONS ARE IN INCHES AND MILLIMETERS

UNITS	P <sup>2</sup>	T <sup>4</sup>	AA	AB	AC	AF	AG	AJ
IN	18.75	-1.69	3.00	16.50	12.25	3.38	36.13	14.750
MM	476	-434		19	311	86	918	374.65

UNITS	AK +.005	BB MIN	BD MAX	BE	BF	BV	CD	EO
IN	13.500	.25	16.50	1.00	.69	13.00	30.00	5.94
MM	342.90	6	419	25	18	330	762	151

TOLERANCES	
FACE RUNOUT PERMISSIBLE	.007 F.I.R.
ECCENTRICITY OF MOUNTING RABBET	.007 F.I.R.

- 1: ALL ROUGH DIMENSIONS MAY VARY BY .25" DUE TO CASTING AND/OR FABRICATION VARIATIONS.
- 2: LARGEST MOTOR WIDTH.
- 3: CONDUIT OPENINGS MAY BE LOCATED IN STEPS OF 90 DEGREES REGARDLESS OF LOCATION. STANDARD AS SHOWN WITH CONDUIT OPENING DOWN.
- 4: (-) MINUS SIGN INDICATES EYEBOLT IS BELOW THE TOP OF THE UNIT.
- 5: TOLERANCES SHOWN ARE IN INCHES ONLY.



# Dimension Prints

## HOLLOSHAFT® Motors, Totally Enclosed Fan Cooled (TU, TUC), Frame 404 & 405TP

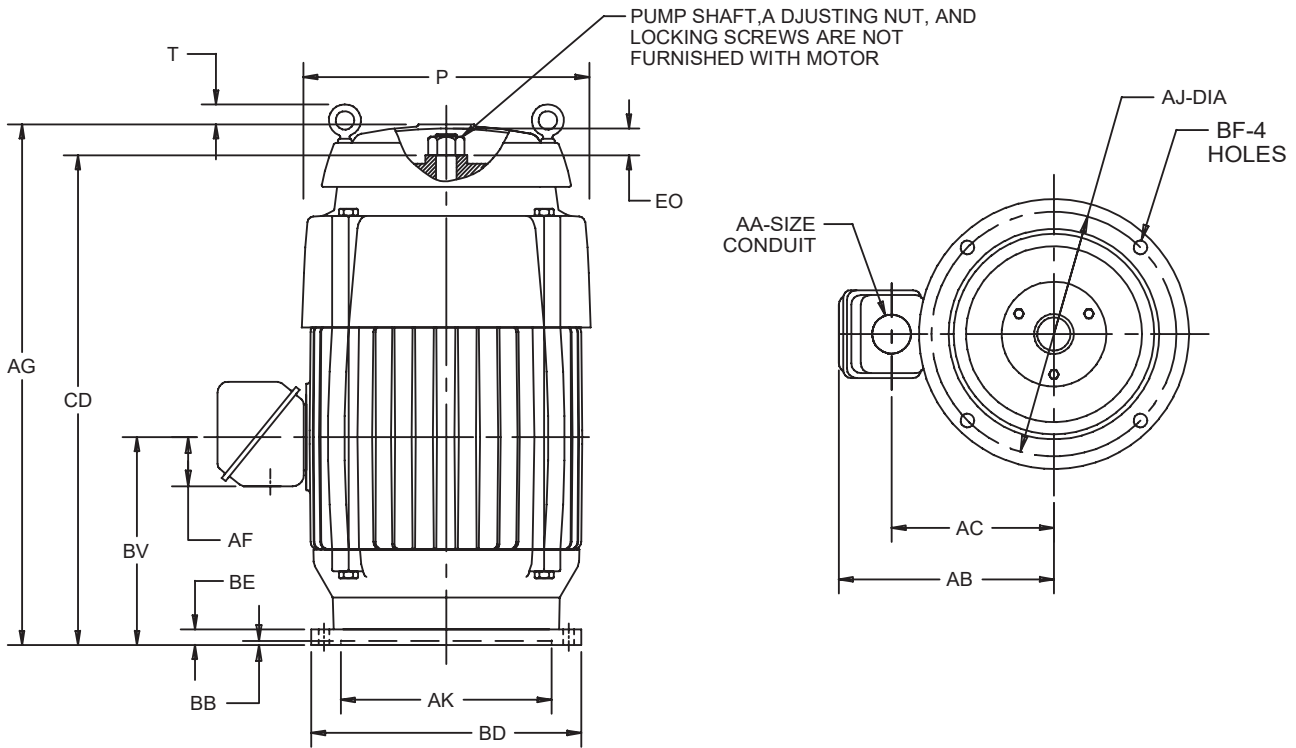

ALL DIMENSIONS ARE IN INCHES & MILLIMETERS

UNITS	P	AA	AB	AC	AF	AG	AJ	AK +.005
IN	24.31	3.00	17.75	13.50	3.38	46.44	14.750	13.500
MM	617		451	343	86	1180	374.65	342.90

UNITS	BB MIN	BE	BF	BV	CD	EO	XO
IN	.25	1.00	.69	15.63	39.94	6.06	24.63
MM	6	25	18	397	1014	154	626

FRAME	UNITS	BD MAX
400TP	IN	16.50
	MM	419
400TPA	IN	20.00
	MM	508

- 1: ALL ROUGH DIMENSIONS MAY VARY BY .25" DUE TO CASTING AND/OR FABRICATION VARIATIONS.
- 2: LARGEST MOTOR WIDTH.
- 3: CONDUIT BOX MAY BE LOCATED IN STEPS OF 90° REGARDLESS OF LOCATION. STANDARD AS SHOWN WITH CONDUIT OPENING DOWN.
- 4: TOLERANCES SHOWN ARE IN INCHES ONLY.

TOLERANCES	
FACE RUNOUT	.007 T.I.R.
PERMISSIBLE ECCENTRICITY OF MOUNTING RABBET	.007 T.I.R.





# Dimension Prints

## HOLLOSHAFT® Motors, Totally Enclosed Fan Cooled (TU, TUC), Frame 440TP

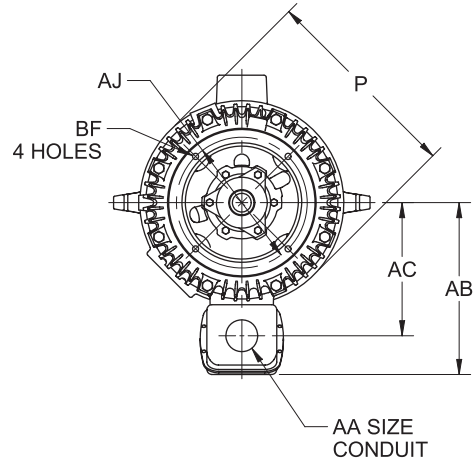
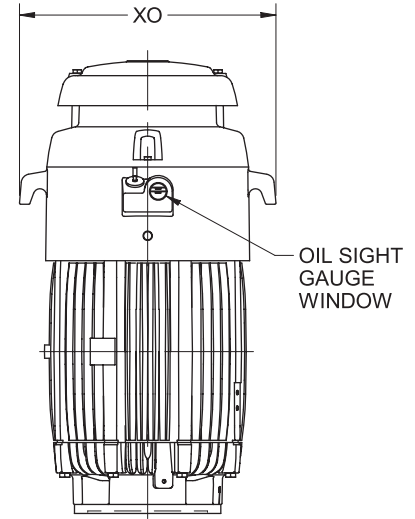
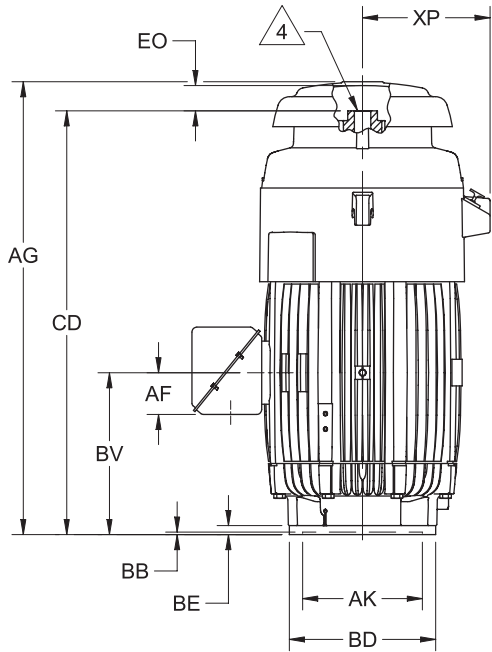

DIMENSIONS ARE IN INCHES AND MILLIMETERS  
(TOLERANCES ARE IN INCHES)

UNITS	P <sup>2</sup>	AJ	AK +.005	BB MIN	BE
IN	23.25	14.750	13.500	.25	1.00
MM	591	374.65	342.90	6	25

UNITS	BF	EO	XO	XP
IN	.69	4.63	28.94	14.38
MM	18	117	735	365

TYPE	UNITS	AA	AB	AC	AF
TU	IN	3.00	19.38	14.88	4.72
	MM		492	378	120
LU	IN	3 NPT	19.66	14.63	4.56
	MM		499	371	116

FRAME	UNITS	AG	BV	CD	FRAME	UNITS	BD MAX
444, 445	IN	47.56	16.50	42.50	440TP	IN	16.50
	MM	1208	419	1080		MM	419
447	IN	51.06	18.25	46.00	440TPA	IN	20.00
	MM	1297	464	1168		MM	508

TOLERANCES	
FACE RUNOUT	.007 T.I.R.
PERMISSIBLE ECCENTRICITY OF MOUNTING RABBET	.007 T.I.R.

1. DIMENSIONS MAY VARY ±.25" DUE TO CASTING AND/OR FABRICATION VARIATIONS.
  2. LARGEST MOTOR WIDTH.
  3. CONDUIT BOX MAY BE ROTATED IN STEPS OF 90 DEGREES. STANDARD AS SHOWN WITH CONDUIT OPENING DOWN.
- ⚠ PUMP SHAFT, ADJUSTING NUT AND LOCKING SCREWS ARE NOT FURNISHED WITH MOTOR.



# Dimension Prints

## HOLLOSHAFT® Motors, Totally Enclosed Fan Cooled (JU, JUC), Frame 449TP

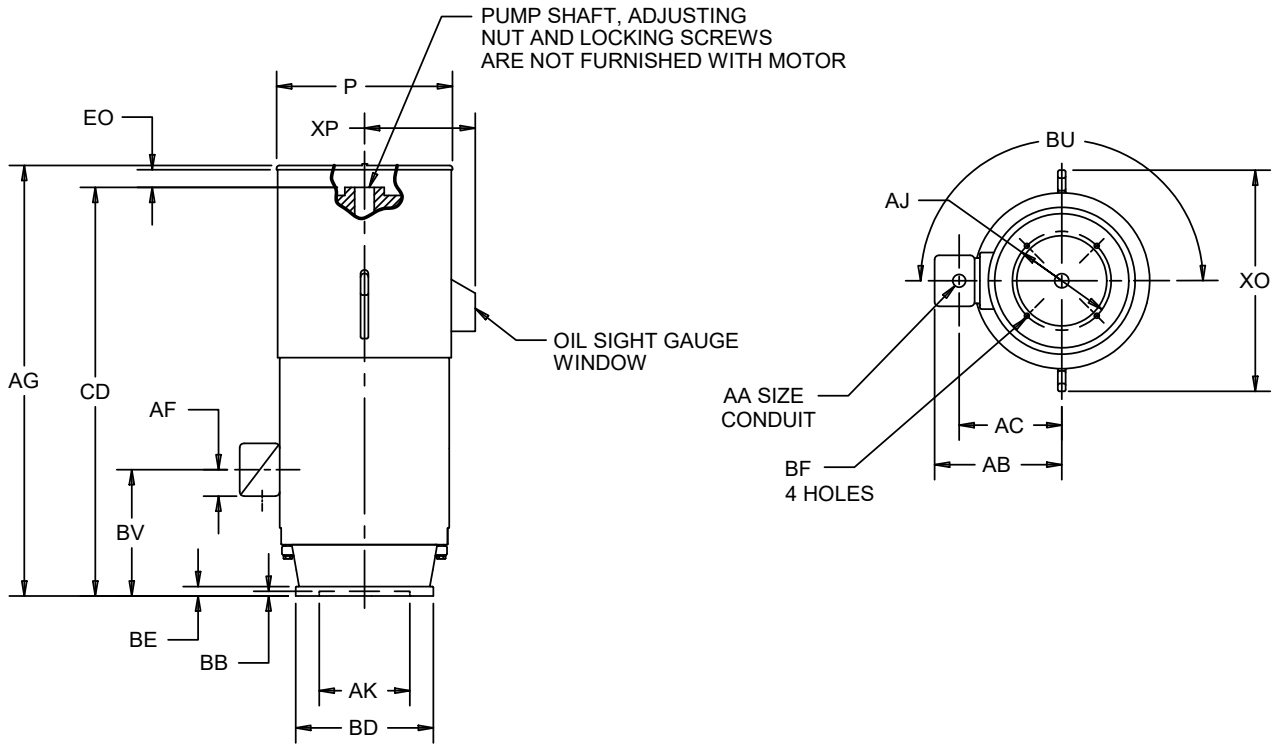

ALL DIMENSIONS ARE IN INCHES AND MILLIMETERS

UNITS	P <sup>2</sup>	AG	AJ	AK +.005	BB	BE	BF
IN	26.25	63.88	14.75	13.500	.25	.88	.69
MM	667	1622	375	342.90	6	22	18

UNITS	BU	BV	CD	EO	XO	XP
IN	180°	12.50	56.88	4.50	33.00	14.50
MM		318	1445	114	838	368

HP	VOLTS	UNITS	AA	AB	AC	AF
ALL	460	IN	3 1/2 NPT	24.00	18.50	8.06
ALL	2300	MM		610	470	209
ALL	4000	IN		25.00	19.50	10.00
		MM		635	495	254

FRAME	UNITS	BD
449TP	IN	24.50
	MM	622
449TPH	IN	20.00
	MM	508

- 1: ALL ROUGH DIMENSIONS MAY VARY BY .25"/6MM DUE TO CASTING AND/OR FABRICATION VARIATIONS.
- 2: LARGEST MOTOR WIDTH.
- 3: CONDUIT OPENINGS MAY BE LOCATED IN STEPS OF 90 DEGREES. STANDARD AS SHOWN WITH CONDUIT OPENING DOWN.

TOLERANCES		
	IN	MM
FACE RUNOUT	.007 T.I.R.	.17 T.I.R.
PERMISSIBLE ECCENTRICITY OF MOUNTING RABBET	.007 T.I.R.	.17 T.I.R.
MAXIMUM SHAFT ENDPLAY	.010	.25



# Dimension Prints

## Vertical Solid Shaft Normal Thrust, Weather Protected Type I (AV), Frame 182 Thru 184 VP

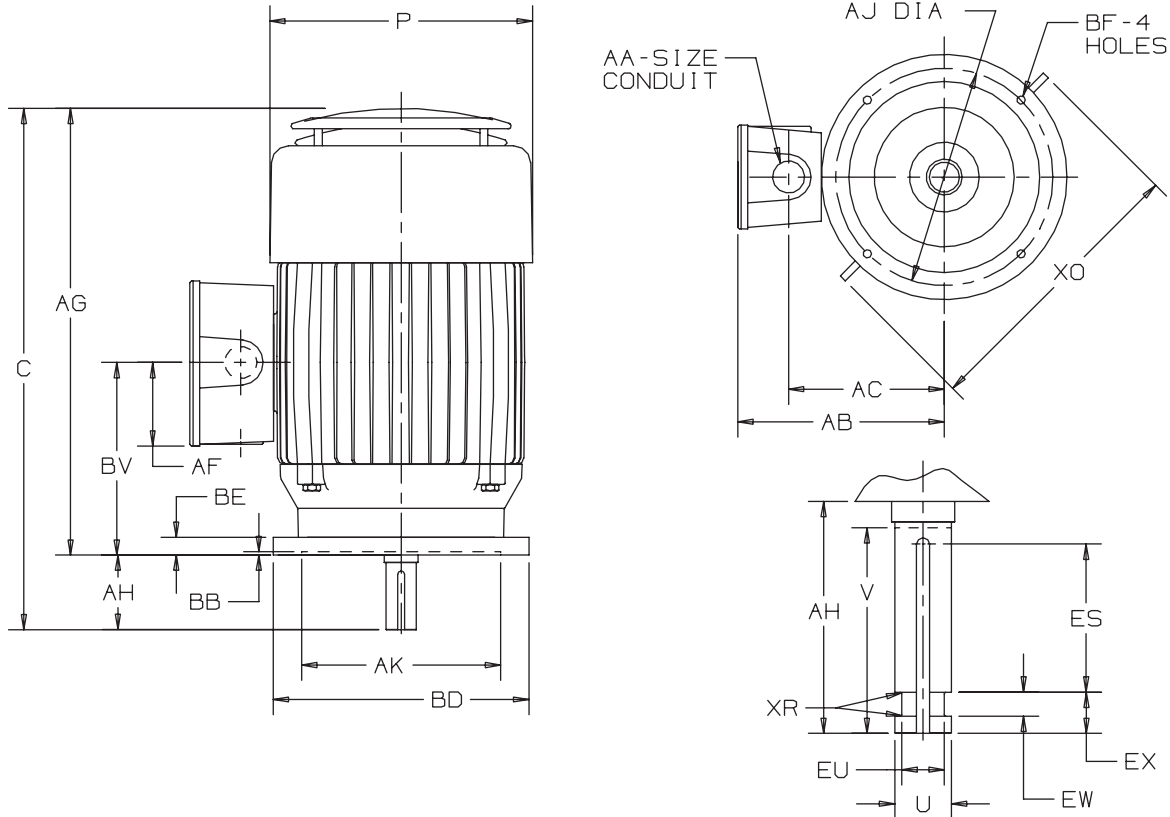

ALL DIMENSIONS ARE IN INCHES & MILLIMETERS

UNITS	C	P <sup>2</sup>	U - .0005	V MIN	AA	AB	AC	AF	AG	AH - .062	AJ	AK + .003
IN	18.00	9.50	1.1250	2.75	1.00	7.30	6.14	2.63	15.25	2.75	9.125	8.250
mm	457	241	285.750	70		185	156	67	387	70	231.78	209.55

UNITS	BB MIN	BD MAX	BE	BF	BV	ES MIN	EU - .005	EW + .002	EX - .005	X0	XR	SQ KEY
IN	.19	10.00	.81	.44	6.50	1.31	.875	.375	.750	11.19	.03	.250
mm	5	254	21	11	165	33	22.23	9.53	19.05	284	.8	6.35

TOLERANCES	
FACE RUNOUT	.004 F.I.R.
PERMISSIBLE ECCENTRICITY OF MOUNTING RABBET	.004 F.I.R.
PERMISSIBLE SHAFT RUNOUT	.002 F.I.R.

- 1: ALL ROUGH CASTING DIMENSIONS MAY VARY BY .25" DUE TO CASTING VARIATIONS.
- 2: LARGEST MOTOR WIDTH.
- 3: CONDUIT OPENING MAY BE LOCATED IN STEPS OF 90 DEGREES, STANDARD AS SHOWN WITH CONDUIT OPENING DOWN
- 4: TOLERANCES SHOWN ARE IN INCHES ONLY.



# Dimension Prints

## Vertical Solid Shaft Normal Thrust, Weather Protected Type I (AV), Frame 213 Thru 215 VP

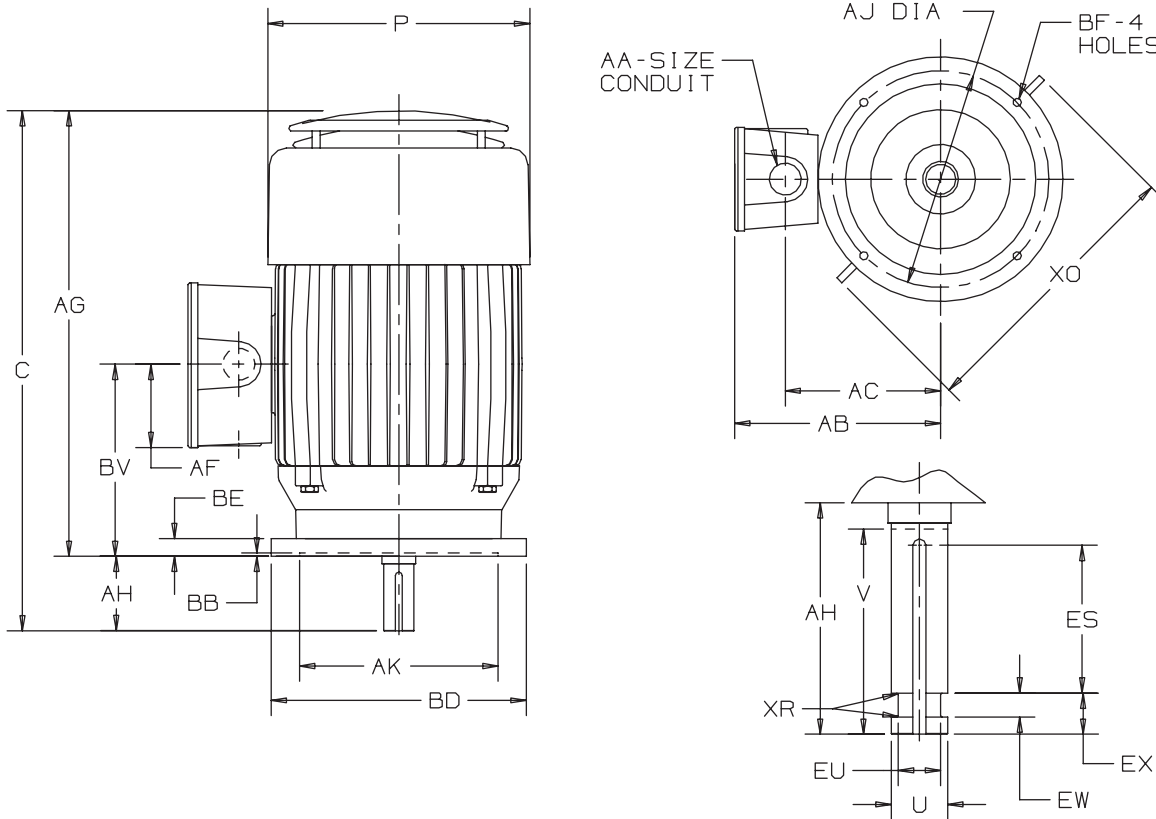

ALL DIMENSIONS ARE IN INCHES & MILLIMETERS

UNITS	C	P <sup>2</sup>	U -.0005	V MIN	AA	AB	AC	AF	AG	AH -.062	AJ	AK +.003
IN	21.84	11.13	1.1250	2.75	1.00	7.86	6.61	3.19	19.09	2.75	9.125	8.250
mm	555	283	28.575	70		200	168	81	485	70	231.78	209.55

UNITS	BB MIN	BD MAX	BE	BF	BV	ES MIN	EU -.005	EW +.002	EX -.005	XO	XR	SQ KEY
IN	.19	10.00	.75	.44	8.00	1.31	.875	.375	.750	12.75	.03	.250
mm	5	254	19	11	203	33	22.23	9.53	19.05	324	.8	6.35

TOLERANCES	
FACE RUNOUT	.004 F.I.R.
PERMISSIBLE ECCENTRICITY OF MOUNTING RABBET	.004 F.I.R.
PERMISSIBLE SHAFT RUNOUT	.002 F.I.R.

- 1: ALL ROUGH CASTING DIMENSIONS MAY VARY BY .25" DUE TO CASTING VARIATIONS.
- 2: LARGEST MOTOR WIDTH.
- 3: CONDUIT OPENING MAY BE LOCATED IN STEPS OF 90 DEGREES, STANDARD AS SHOWN WITH CONDUIT OPENING DOWN
- 4: TOLERANCES SHOWN ARE IN INCHES ONLY.

† All marks shown within this document are properties of their respective owners.



# Dimension Prints

## Normal Thrust Solid Shaft Motors, Weather Protected Type I (AV), Frame 254 & 256VP

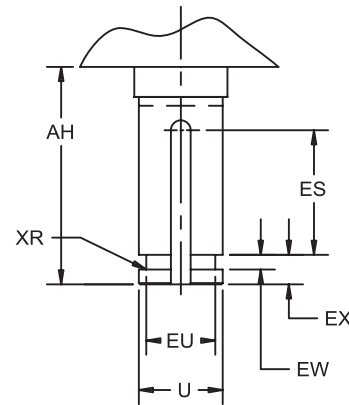
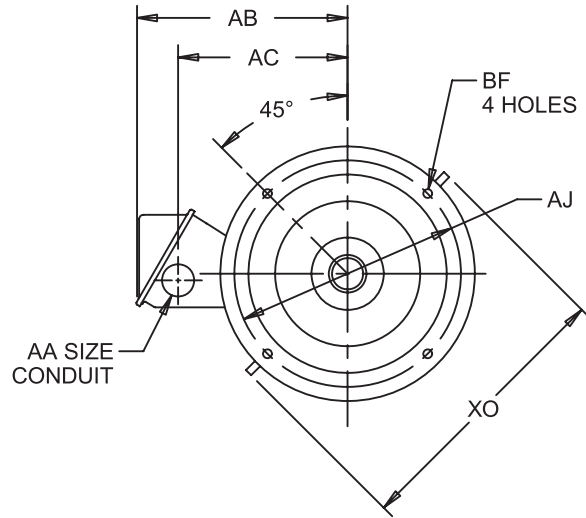
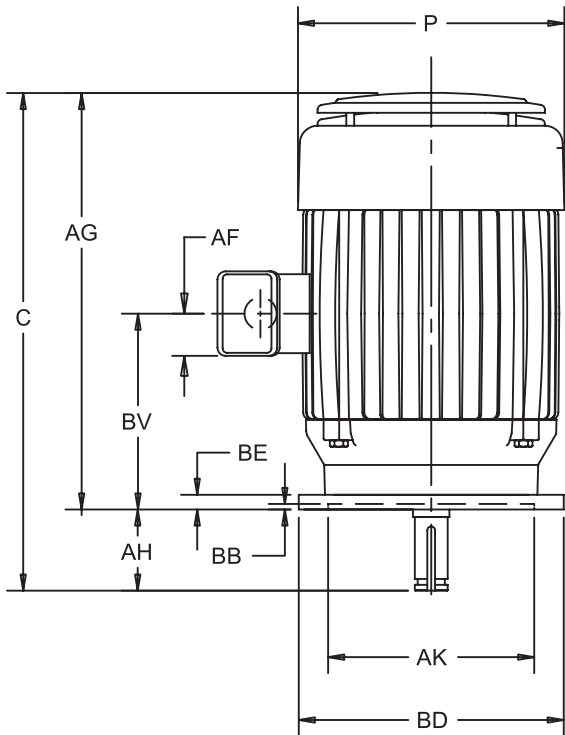

ALL DIMENSIONS ARE IN INCHES AND MILLIMETERS

UNITS	C	P <sup>2</sup>	U -.0005	AA	AB	AC	AF	AG	AH ±.063	AJ	AK +.003
IN	22.00	13.38	1.1250	1.25	10.25	7.88	2.03	19.25	2.750	9.125	8.250
MM	559	340	28.575		260	200	52	489	69.85	231.78	209.55

UNITS	BB MIN	BE	BF	BV	ES MIN	EU -.005	EW +.002	EX -.005	XO	XR	SQ KEY
IN	.19	.94	.44	12.75	1.31	.875	.375	.750	16.88	.03	.250
MM	5	24	11	324	33	22.23	9.53	19.05	429	1	6.35

FRAME	UNITS	BD MAX
254, 256VP	IN	10.00
	MM	254
254, 256VPH	IN	12.00
	MM	305

- 1: ALL ROUGH DIMENSIONS MAY VARY BY .25" DUE TO CASTING AND/OR FABRICATION VARIATIONS.
- 2: LARGEST MOTOR WIDTH.
- 3: CONDUIT OPENING MAY BE LOCATED IN STEPS OF 180 DEGREES. STANDARD AS SHOWN WITH CONDUIT OPENING DOWN.
- 4: TOLERANCES SHOWN ARE IN INCHES ONLY.

TOLERANCES	
FACE RUNOUT	.004 T.I.R.
PERMISSIBLE ECCENTRICITY OF MOUNTING RABBET	.004 T.I.R.
PERMISSIBLE SHAFT RUNOUT	.002 T.I.R.



# Dimension Prints

## Normal Thrust Solid Shaft Motors, Weather Protected Type I (AV), Frame 284 & 286VP

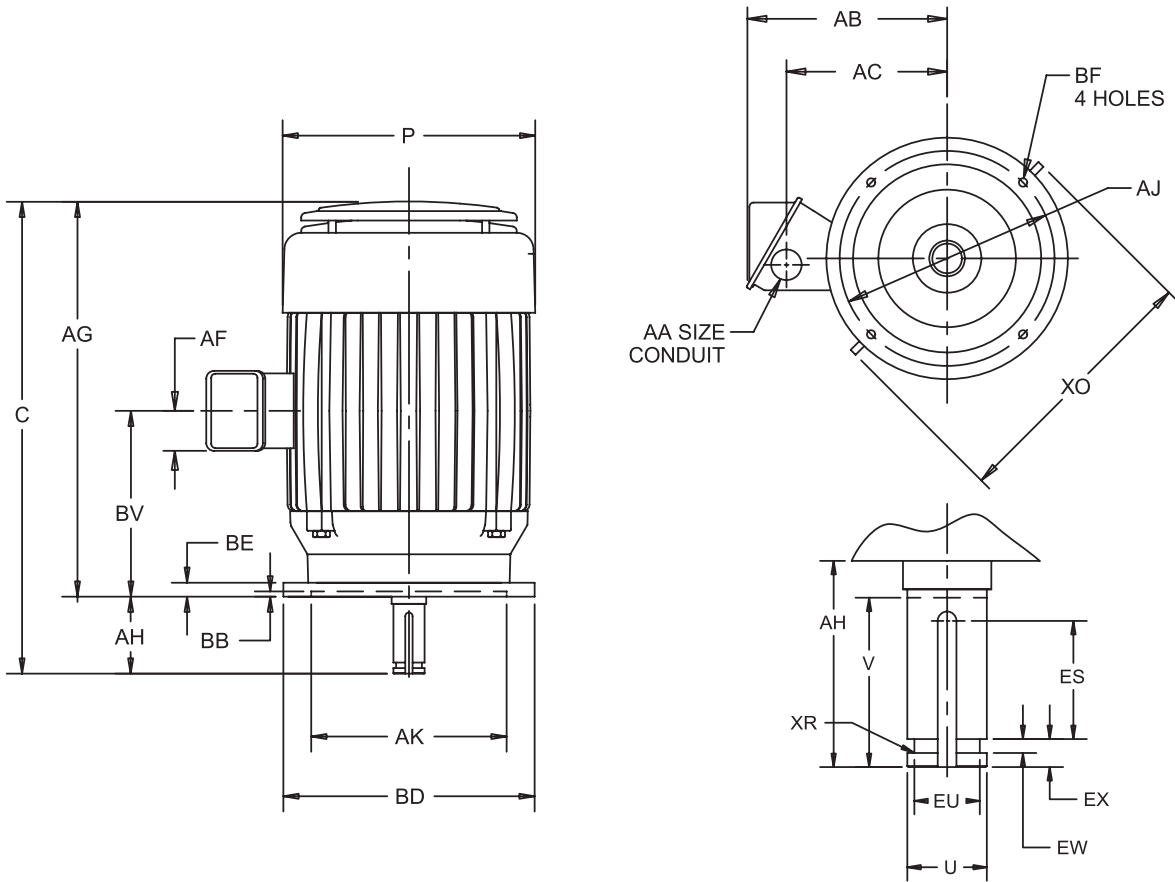

ALL DIMENSIONS ARE IN INCHES AND MILLIMETERS

UNITS	P <sup>2</sup>	AA	AB	AC	AF	AG	BE	BV	EU +.002	EX -.005	XO	XR
IN	14.00	1.50	11.07	8.32	2.59	21.75	1.00	14.75	.375	.750	16.88	.03
MM	356		281	211	66	552	25	375	9.53	19.05	429	1

FRAME	UNITS	C	U -.001	V MIN	AH -.062	AJ	AK	BB MIN	BD MAX	BF	ES MIN	EU -.005	SQ KEY
284,286VPZ	IN	26.25	1.625	4.50	4.500	9.125	8.250	.19	10.00	.44	3.06	1.250	.375
	MM	667	41.28	114	114.30	231.78	209.55	5	254	11	78	31.75	9.53
284,286VPAZ	IN	26.25	1.625	4.50	4.500	9.125	8.250	.19	12.00	.44	3.06	1.250	.375
	MM	667	41.28	114	114.30	231.78	209.55	5	305	11	78	31.75	9.53
284,286VPHZ	IN	26.25	1.625	4.50	4.500	14.750	13.500	.25	16.50	.69	3.06	1.250	.375
	MM	667	41.28	114	114.30	374.65	342.90	6	419	18	78	31.75	9.53
284,286VP	IN	24.50	1.1250	2.75	2.750	9.125	8.250	.19	10.00	.44	1.31	.875	.250
	MM	622	28.575	70	69.85	231.78	209.55	5	254	11	33	22.23	6.35
284,286VPA	IN	24.50	1.1250	2.75	2.750	9.125	8.250	.19	12.00	.44	1.31	.875	.250
	MM	622	28.575	70	69.85	231.78	209.55	5	305	11	33	22.23	6.35
284,286VPH	IN	24.50	1.1250	2.75	2.750	14.750	13.500	.25	16.50	.69	1.31	.875	.250
	MM	622	28.575	70	69.85	374.65	342.90	6	49	18	33	22.23	6.35

- ALL ROUGH DIMENSIONS MAY VARY BY .25" DUE TO CASTING AND/OR FABRICATION VARIATIONS.
- LARGEST MOTOR WIDTH.
- CONDUIT OPENINGS MAY BE LOCATED IN STEPS OF 180°. STANDARD AS SHOWN WITH CONDUIT OPENING DOWN.
- TOLERANCES SHOWN ARE IN INCHES ONLY.
- SHAFT EXTENSION DIAMETER TOLERANCE: +.0000;-.0005 UP TO 1-1/2" INCLUSIVE.  
LARGE DIMETERS: +.000;-0.01

TOLERANCES	8.250 AK	13.500 AK
FACE RUNOUT	.004 T.I.R.	.007 T.I.R.
PERMISSIBLE ECCENTRICITY OF MOUNTING RABBET	.004 T.I.R.	.007 T.I.R.
PERMISSIBLE SHAFT RUNOUT	.002 T.I.R.	.002 T.I.R.
TOLERANCE ON AK-DIMENSION	+.003	+.005



# Dimension Prints

## Normal Thrust Solid Shaft Motors, Weather Protected Type I (AV), Frame 324 & 326VP

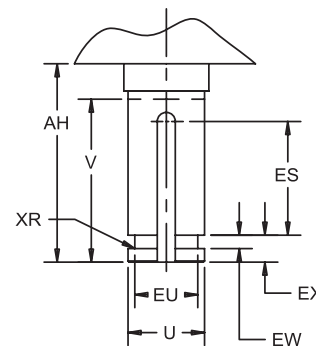
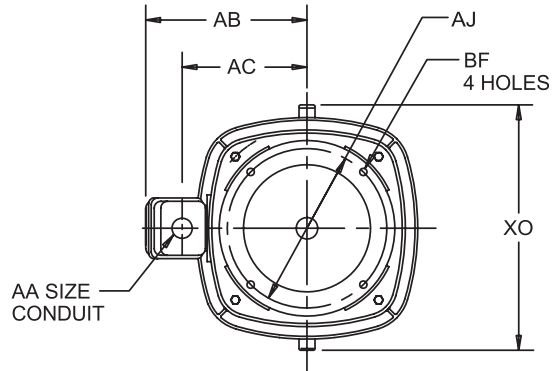
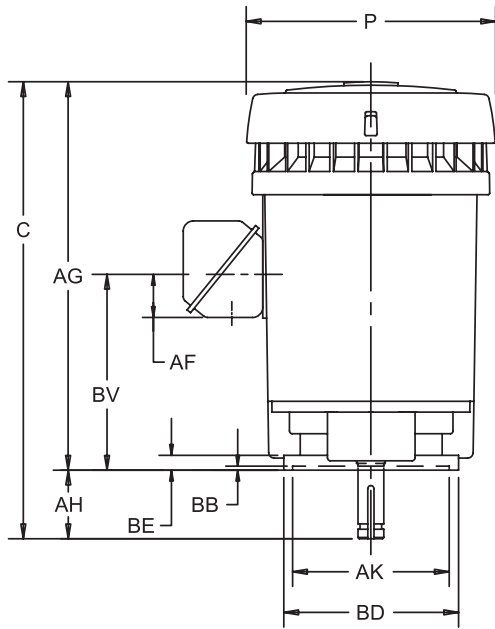

DIMENSIONS ARE IN INCHES AND MILLIMETERS

UNITS	C	P <sup>1</sup>	U -.001	V MIN	AA	AB	AC	AF	AG	AH	BV
IN	29.44	18.25	1.625	4.50	3.00	15.75	11.50	3.38	24.94	4.50	13.38
MM	748	464	41.28	114		400	292	86	633	114	340

UNITS	ES MIN	EU -.005	EW +.002	EX -.005	XO	XR	SQ KEY
IN	3.03	1.250	.375	.750	20.94	.03	.375
MM	77	31.75	9.53	19.05	532	1	9.53

FRAME	UNITS	AJ	AK	BB MIN	BD MAX	BE	BF
324,326VP	IN	14.750	13.500	.25	16.50	.69	.69
	MM	374.65	342.90	6	419	18	18
324,326VPH	IN	9.125	8.250	.19	12.00	.94	.44
	MM	231.78	209.55	5	305	24	11

- 1) ALL ROUGH DIMENSIONS MAY VARY BY .25" DUE TO CASTING AND/OR FABRICATION VARIATIONS.
- 2) LARGEST MOTOR WIDTH.
- 3) CONDUIT BOX OPENING MAY BE LOCATED IN STEPS OF 90 DEGREES. STANDARD AS SHOWN WITH CONDUIT OPENING DOWN.
- 4) TOLERANCES SHOWN ARE IN INCHES ONLY.

TOLERANCES	8.250 AK	13.500 AK
FACE RUNOUT	.004 T.I.R.	.007 T.I.R.
PERMISSIBLE ECCENTRICITY OF MOUNTING RABBET	.004 T.I.R.	.007 T.I.R.
PERMISSIBLE SHAFT RUNOUT	.002 T.I.R.	.002 T.I.R.
"AK" DIMENSION	+.003/-0.000	+.005/-0.000





# Dimension Prints

## Normal Thrust Solid Shaft Motors, Weather Protected Type I (AV), Frame 364 & 365VP

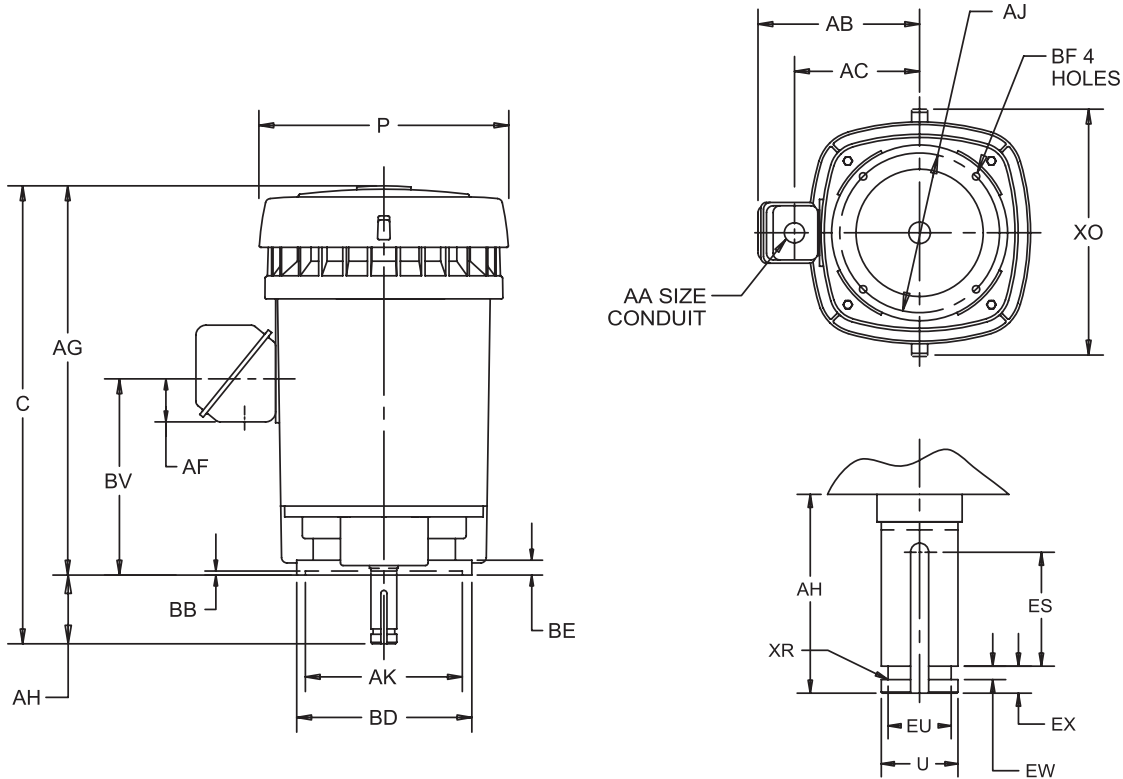

ALL DIMENSIONS ARE IN INCHES AND MILLIMETERS

UNITS	C	P <sup>2</sup>	AA	AB	AC	AF	AG	AH	BV	ES MIN	EW +.002	EX -.005	XO	XR
IN	32.38	18.25	3.00	15.75	11.50	3.38	27.88	4.50	15.31	3.03	.375	.750	20.94	.03
MM	822	464		400	292	86	708	114	340	77	9.53	19.05	532	1

FRAME	UNITS	AJ	AK	BB MIN	BD MAX	BE	BF	FRAME	UNITS	U -.001	EU -.005	SQ KEY
360VP, VPZ	IN	14.750	13.500	.25	16.50	.69	.69	360VP, VPA	IN	1.625	1.250	.375
	MM	374.65	342.90	6	419	18	18		MM	41.28	31.75	9.53
360VPA, VPAZ	IN	9.125	8.250	.19	12.00	.94	.44	360VPZ, VPAZ	IN	2.125	1.750	.500
	MM	231.78	209.55	5	305	24	11		MM	53.98	44.45	12.70

TOLERANCES	8.250 AK	13.500 AK
FACE RUNOUT	.004 T.I.R.	.007 T.I.R.
PERMISSIBLE ECCENTRICITY OF MOUNTING RABBET	.004 T.I.R.	.007 T.I.R.
PERMISSIBLE SHAFT RUNOUT	.002 T.I.R.	.002 T.I.R.
TOLERANCE ON AK-DIMENSION	+.003	+.005

- 1: ALL ROUGH DIMENSIONS MAY VARY BY .25" DUE TO CASTING AND/OR FABRICATION VARIATIONS.
- 2: LARGEST MOTOR WIDTH.
- 3: CONDUIT OPENINGS MAY BE LOCATED IN STEPS OF 90 DEGREES REGARDLESS OF LOCATION. STANDARD AS SHOWN WITH CONDUIT OPENING DOWN.
- 4: TOLERANCES SHOWN ARE IN INCHES ONLY.



# Dimension Prints

## Normal Thrust Solid Shaft Motors, Weather Protected Type I (AV), Frame 404 & 405VP

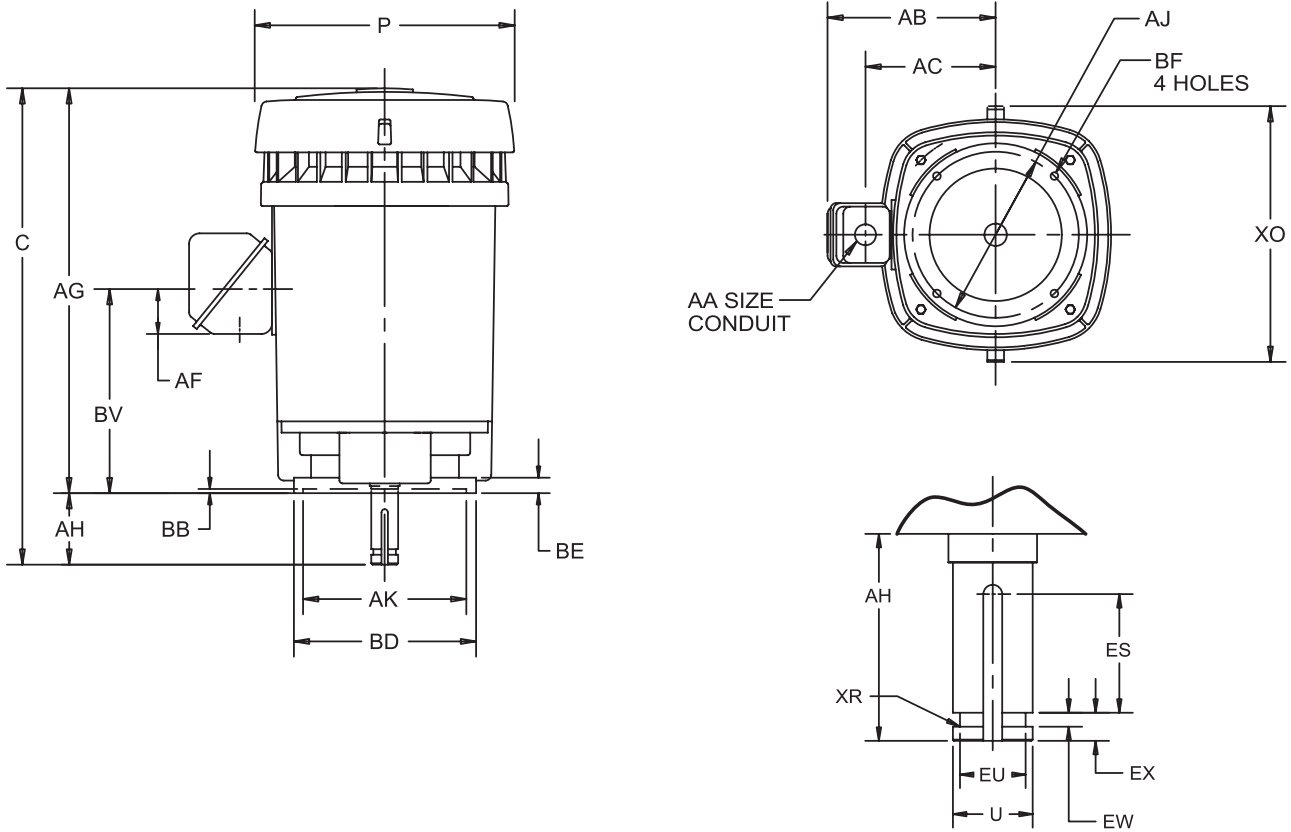

DIMENSIONS ARE IN INCHES AND MILLIMETERS

UNITS	C	P <sup>1</sup>	AA	AB	AC	AF	AG	AH	AJ	AK +.005	BB MIN
IN	36.25	20.50	3.00	16.84	12.63	3.38	31.75	4.50	14.750	13.500	.25
MM	921	521		428	321	86	807	114	374.65	342.90	6

UNITS	BE	BF	BV	DQ	ES MIN	EW +.002	EX -.005	XO	XR
IN	.75	.69	18.13	13.56	3.03	.375	.750	23.38	.03
MM	19	18	461	344	77	9.53	19.05	594	1

FRAME	UNITS	U	EU	SQ	FRAME	UNITS	BD
		-.001	-.005	KEY			MAX
400VP,VPA	IN	1.625	1.250	.375	404,405VP	IN	16.50
	MM	41.28	31.75	9.53	404,405VPZ	MM	419
400VPZ,VPAZ	IN	2.125	1.750	.500	404,405VPA	IN	20.00
	MM	53.98	44.45	12.70	404,405VPAZ	MM	508

- 1) ALL ROUGH DIMENSIONS MAY VARY BY .25" DUE TO CASTING AND/OR FABRICATION VARIATIONS.
- 2) CONDUIT BOX OPENING MAY BE LOCATED IN STEPS OF 90°. STANDARD AS SHOWN WITH CONDUIT OPENING DOWN.
- 3) LARGEST MOTOR WIDTH.
- 4) TOLERANCES SHOWN ARE IN INCHES ONLY.

TOLERANCES	
FACE RUNOUT	.007 T.I.R.
PERMISSIBLE ECCENTRICITY OF MOUNTING RABBET	.007 T.I.R.
PERMISSIBLE SHAFT RUNOUT	.002 T.I.R.



# Dimension Prints

## Normal Thrust Solid Shaft Motors, Totally Enclosed Fan Cooled (TVCS), Frame 143 – 286HP

### Typical Dimensions For Reference Only

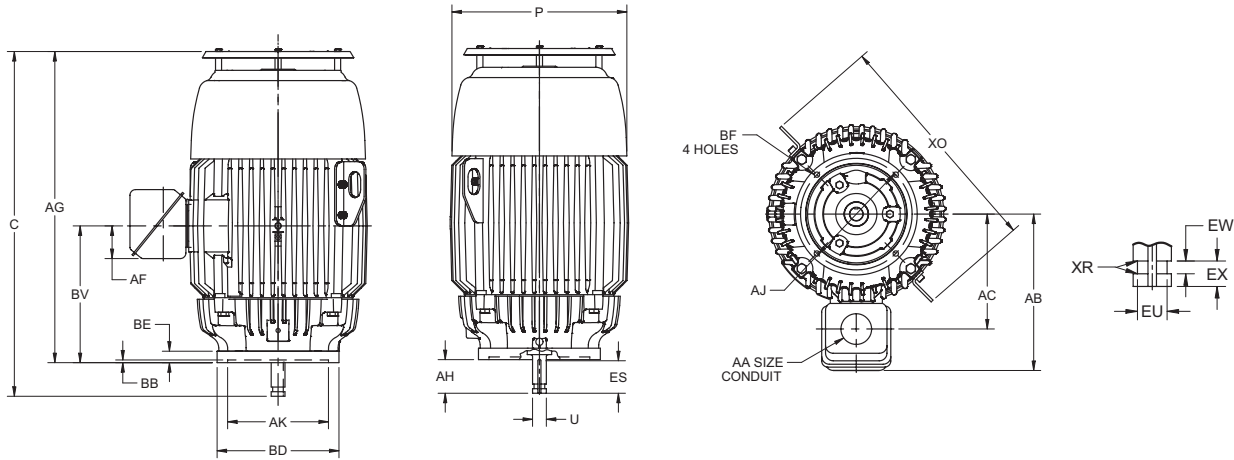

ALL DIMENSIONS ARE IN INCHES

FRAME	AF	AG	BE	BV	X0
143, 145HP	1.75	12.63	0.56	6.81	-
182, 184HP	2	17.25	0.63	7.63	12.16
213, 215HP	2	19.66	0.63	8	13.75
254, 256HP, HPH	2.53	23.78	0.63	10	15.96
284, 286HP, HPA, HPH	3.25	26	0.94	11.19	18.81
284, 286HPZ, HPAZ, HPHZ	2.562	28.125	0.94	14.75	15.875

FRAME	C	P3	AA	AB	AC
143, 145HP	15.38	7.75	0.75	7.88	6.31
182, 184HP	20	9.5	0.75	7.88	5.69
213, 215HP	22.41	11	1	8.88	6.71
254, 256HP, HPH	26.53	13.31	1.50	11.31	8.5
284, 286HP, HPA, HPH	28.75	14.59	2.0	13.31	9.69
284, 286HPZ, HPAZ, HPHZ	32.625	13.375	1.5	10.75	8.25

FRAME	U2	V MIN	AH ± .062	AJ	AK	BB MIN	BD	BF	ES MIN	"EU -.005"	SQ KEY
143, 145HP	0.875	2.75	2.75	9.125	8.25	0.19	10	0.44	1.28	0.688	0.188
182, 184HP	1.125	2.75	2.75	9.125	8.25	0.19	10	0.44	1.28	0.875	0.25
213, 215HP	1.125	2.75	2.75	9.125	8.25	0.19	10	0.44	1.28	0.875	0.25
254, 256HPH	1.125	2.75	2.75	9.125	8.25	0.19	10	0.44	1.28	0.875	0.25
254, 256HP	1.125	2.75	2.75	9.125	8.25	0.19	12	0.44	1.28	0.875	0.25
284, 286HP	1.125	2.75	2.75	9.125	8.25	0.19	10	0.44	1.28	0.875	0.25
284, 286HPA	1.125	2.75	2.75	9.125	8.25	0.19	12	0.44	1.28	0.875	0.25
284, 286HPH	1.125	2.75	2.75	14.75	13.5	0.25	16.5	0.69	1.28	0.875	0.25
284, 286HPZ	1.625	4.5	4.5	9.125	8.25	0.19	10	0.44	3.06	1.25	0.375
284, 286HPAZ	1.625	4.5	4.5	9.125	8.25	0.19	12	0.44	3.06	1.25	0.375
284, 286HPHZ	1.625	4.5	4.5	14.75	13.5	0.25	16.5	0.69	3.06	1.25	0.375

- 1: ALL ROUGH CASTING DIMENSIONS MAY VARY BY .25" DUE TO CASTING VARIATIONS.
- 2: SHAFT EXTENSION DIAMETER TOLERANCE: +.0000; -.0005 UP 1-1/2" INCLUSIVE. LARGE DIAMETERS: +.000; -.001.
- 3: LARGEST MOTOR WIDTH.
- 4: CONDUIT OPENING MAY BE LOCATED IN STEPS OF 90°. STANDARD AS SHOWN WITH CONDUIT OPENING DOWN.

TOLERANCES	8.25 AK	13.5 AK
FACE RUNOUT	.004 T.I.R.	.006 T.I.R.
PERMISSIBLE ECCENTRICITY OF MOUNTING RABBET	.004 T.I.R.	.006 T.I.R.
PERMISSIBLE SHAFT RUNOUT	.002 T.I.R.	.002 T.I.R.
"AK" DIMENSION	+.000; -.003	+.000; -.005



# Dimension Prints

## Normal Thrust Solid Shaft Motors, Totally Enclosed Fan Cooled (TVCS), Frame 324 – 447HP

### Typical Dimensions For Reference Only

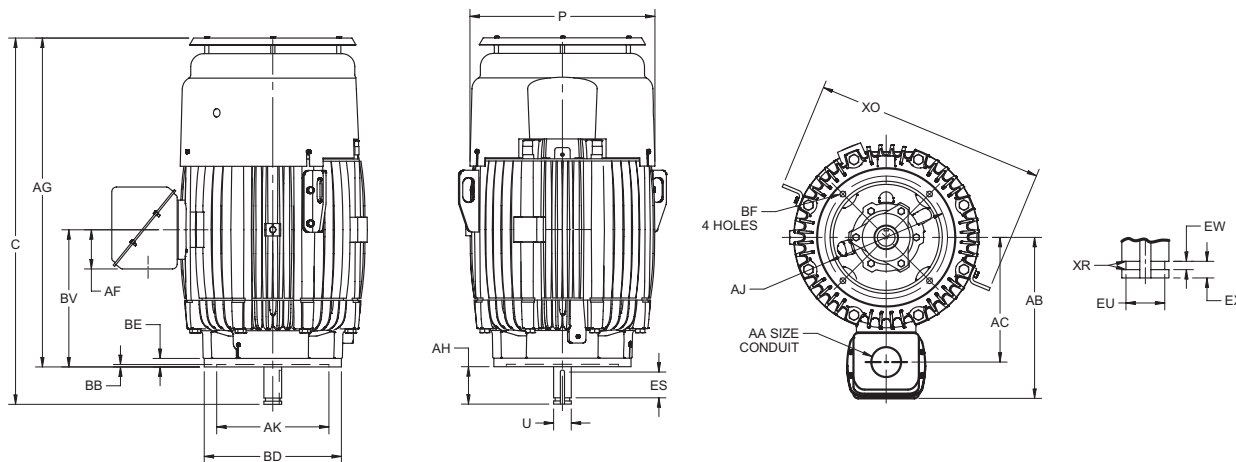

ALL DIMENSIONS ARE IN INCHES

FRAME	AF	AG	BE	BV	XO
324, 326HP, HPH	3.25	28.16	1	11.94	21.13
364, 365	3.38	29.22	1	12.94	23
404, 405	4.72	34.38	1	15.63	26
444, 445	4.72	39.56	1	16.5	27.75
447	4.72	43.06	1	18.25	27.75

FRAME	C	P3	AA	AB	AC
324, 326HP, HPH	32.66	16.56	2	14	10.75
364, 365	33.72	18	3	16.5	12.19
404, 405	38.88	20.88	3	18.42	14.13
444, 445	44.06	22.25	3	19.38	15
447	47.56	22.25	3	19.38	15

FRAME	U2	V MIN	AH ± .062	AJ	AK	BB MIN	BD	BF	ES MIN	EU -.005	SQ KEY
324, 326HP	1.625	4.50	4.50	14.750	13.50	0.25	16.5	0.69	3.03	1.25	0.375
324, 326HPH	1.625	4.50	4.50	9.125	8.25	0.19	12	0.44	3.03	1.25	0.375
364, 365HP	1.625	4.50	4.50	14.75	13.50	0.25	16.5	0.69	3.03	1.25	0.375
364, 365HPZ	2.125	4.50	4.50	14.75	13.50	0.25	16.5	0.69	3.03	1.75	0.50
404, 405HP	1.625	4.50	4.50	14.75	13.50	0.25	16.5	0.69	3.03	1.25	0.375
404, 405HPA	1.625	4.50	4.50	14.75	13.50	0.25	20	0.69	3.03	1.75	0.375
444, 445, 447HP	2.125	4.50	4.50	14.75	13.50	0.25	16.5	0.69	3.03	1.75	0.50
444, 445, 447HPA	2.125	4.50	4.50	14.75	13.50	0.25	20.0	0.69	3.03	1.75	0.50

TOLERANCES	8.25 AK	13.50 A.K.
"AK" DIMENSION	.003; -0.000	.005; -.000
FACE RUNOUT	.004 T.I.R.	.006 T.I.R.
PERMISSIBLE ECCENTRICITY OF MOUNTING RABBET	.004 T.I.R.	.006 T.I.R.
PERMISSIBLE SHAFT RUNOUT	.002 T.I.R.	.002 T.I.R.

- 1: ALL ROUGH CASTING DIMENSIONS MAY VARY BY .25" DUE TO CASTING VARIATIONS.
- 2: LARGEST MOTOR WIDTH
3. CONDUIT OPENING MAY BE LOCATED IN STEPS OF 90°. STANDARD AS SHOWN WITH CONDUIT OPENING DOWN.



# Dimension Prints

## Vertical C-Face Motors, Totally Enclosed Fan Cooled (TCEF), Frame 140TC

Typical Dimensions For Reference Only

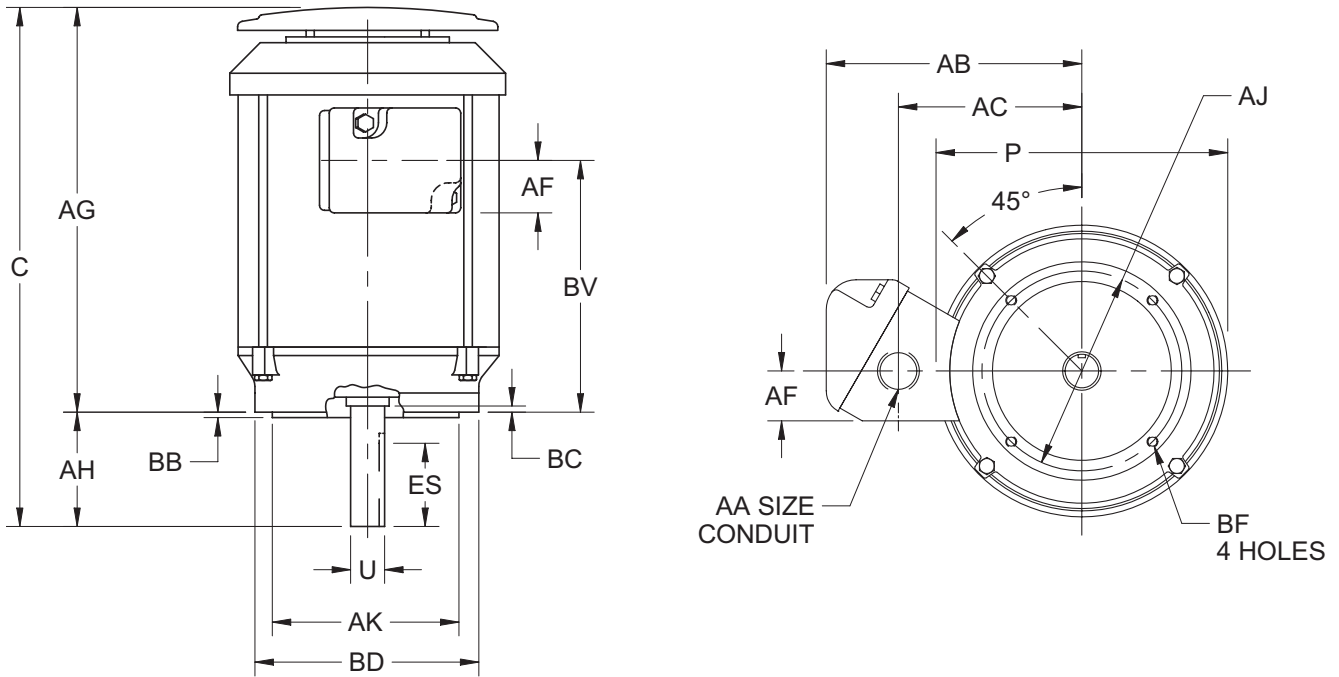

ALL DIMENSIONS ARE IN INCHES

Speed	Frame Size	C	P2	U	AA	AB	AC	AF	AG	AH	AK	BB
2 pole	143	15	7.75	0.875	3/4 NPT	6.38	4.56	1.25	12.88	2.13	4.5	0.13
	145TC											
4 pole	143	16.25	7.75	0.875								
	145TC											

Frame Size	BC	BD	BF	BV	ES	SQ
143	0.13	6.5	3/8-16X.56	6.81	1.41	0.188
145TC						
143	0.13	6.5	3/8-16X.56	8.06	1.41	0.188
145TC						

1. ALL ROUGH CASTING DIMENSIONS MAY VARY BY .25" DUE TO CASTING AND/OR FABRICATION VARIATIONS.
2. LARGEST MOTOR WIDTH.

TOLERANCES	
FACE RUNOUT	.007 T.I.R.
PERMISSIBLE ECCENTRICITY OF MOUNTING RABBET	.007 T.I.R.
PERMISSIBLE SHAFT RUNOUT	.003 T.I.R.

† All marks shown within this document are properties of their respective owners.

Revised — April 2019



# Dimension Prints

## Vertical C-Face Motors, Totally Enclosed Fan Cooled (TCEF), Frame 182 – 405TC

### Typical Dimensions For Reference Only

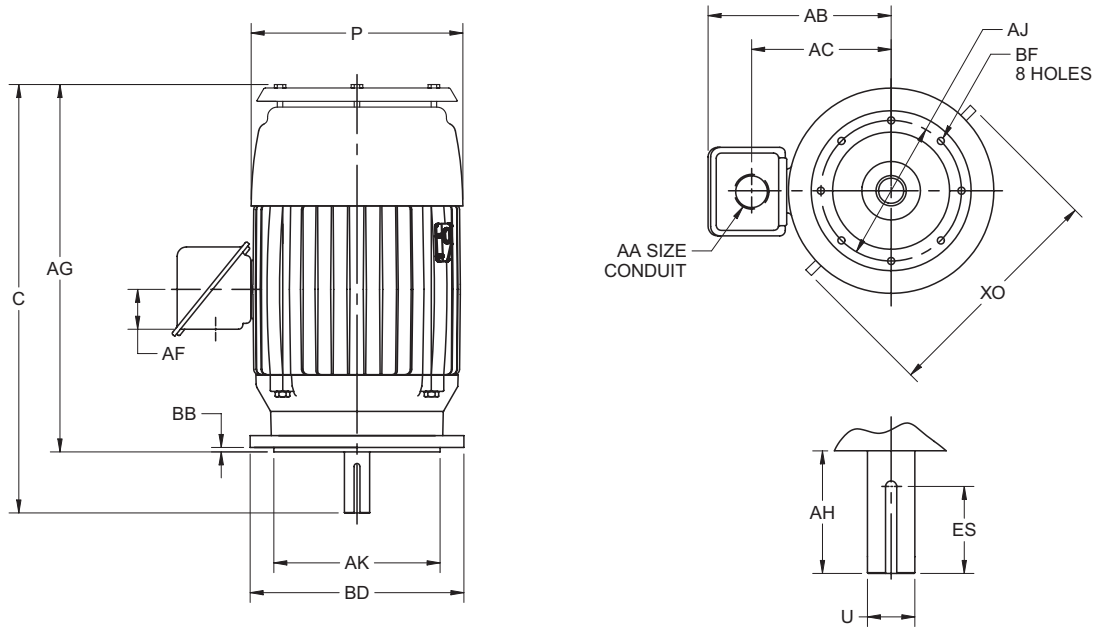

### ALL DIMENSIONS ARE IN INCHES

Frame Size	C	P <sup>2</sup>	U	AA	AB	AC	AF	AG	AH	AK	BB
182	18.63	9.5	1.125	3/4 NPT	8.03	5.75	2.13	16	2.63	8.5	0.25
184TC											
210TC	22.75	11.13	1.375	1 NPT	9.75	7.25	2	19.63	3.12	8.5	0.25
250TC	26.34	13.31	1.625	3/2 NPT	11.5	8.53	2.63	22.59	3.75	8.5	0.31
280TSC	28.27	15.59	1.625	3/2 NPT	11.94	8.94	2.63	25.27	3	10.5	0.25
280TC	29.65	14.59	1.875	3/2 NPT	11.94	8.94	2.63	25.27	4.38	10.5	0.25
320TC	32.63	16.75	2.125	2 NPT	14.25	10.75	3.25	27.63	5	12.5	0.25
320TSC	31.13	16.75	1.875	2 NPT	14.25	10.75	3.25	27.63	3.5	12.5	0.25
360TSC	30.95	16.75	1.875	3 NPT	17.13	12.88	4.63	27.45	3.5	12.5	0.25
360TC	33.08	16.75	2.375	3NPT	17.13	12.88	4.63	27.45	5.63	12.5	0.25
405TSC	37.63	17.88	2.125	3 NPT	18.69	14.13	4.88	33.63	4	12.5	0.25
405TC	40.63	20.88	2.875	3 NPT	18.69	14.13	4.88	33.63	7	12.5	0.25

Frame Size	BC	BD	BF	BV	ES	SQ Key	BE	XO
182	0.13	9	1/2-13X.75	6.41	1.78	0.25	0.63	12.13
184TC								
210TC	0.25	9	1/2-13X.75	8	2.41	0.313	-	13.76
250TC	0.25	10	1/2-13X.75	10	2.91	0.375	0.63	15.96
280TSC	0.25	11.25	1/2-13X.75	10.5	1.91	375	-	18.52
280TC	0.25	11.25	1/2-13X.75	10.5	3.28	0.5	-	18.52
320TC	-	14	5/8 11X.94	11.5	3.91	0.5	-	21.14
320TSC	-	14	5/8 11X.94	11.5	2.03	0.5	-	21.14
360TSC	-	14	5/8 11X.94	12.25	2.03	0.5	-	23
360TC	-	14	5/8 11X.94	12.25	4.28	0.625	-	23
405TSC	-	15.5	5/8 11X.94	15.63	3.13	0.5	-	26
405TC	-	15.5	5/8 11X.94	15.63	5.65	0.75	-	26

1. ALL ROUGH CASTING DIMENSIONS MAY VARY BY .25" DUE TO CASTING AND/OR FABRICATION VARIATIONS.
2. TAP SIZE AND BOLT PENETRATION ALLOWANCE.
3. ALL TAPPED HOLES ARE UNIFIED NATIONAL COARSE RIGHT | HAND THREAD
4. CONDUIT OPENING MAY BE LOCATED IN STEPS OF 90°. STANDARD AS SHOWN WITH CONDUIT OPENING DOWN.
5. LARGEST MOTOR WIDTH.
6. TOLERANCES SHOWN ARE IN INCHES ONLY.

TOLERANCES	
FACE RUNOUT	.007 T.I.R.
PERMISSIBLE ECCENTRICITY OF MOUNTING RABBET	.007 T.I.R.
PERMISSIBLE SHAFT RUNOUT	.003 T.I.R.
FOR SPECIAL SHAFT RUNOUT (BALL BRG)	.0015 T.I.R.



## Dimension Prints

### Vertical C-Face Motors, Totally Enclosed Fan Cooled (TCEF), Frame 440TC

#### Typical Dimensions For Reference Only

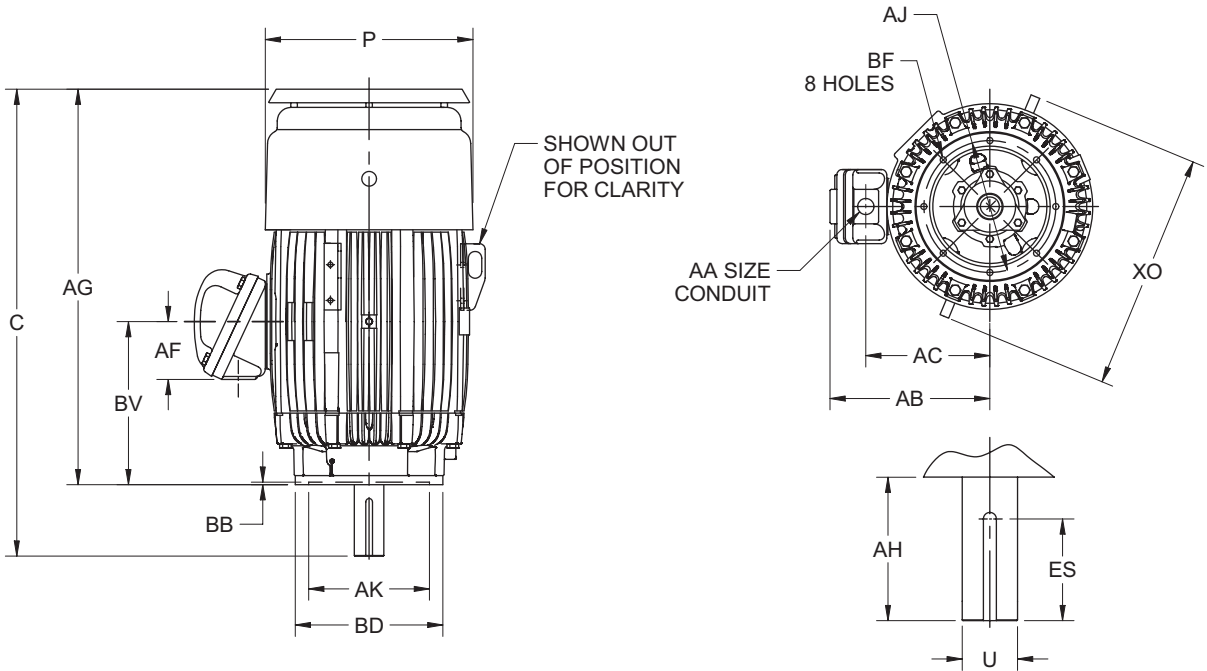

#### ALL DIMENSIONS ARE IN INCHES

Frame Size	C	P2	U	AA	AB	AC	AF	AG	AH	AK	BB
444	42.97	23.5	2.375	3.5 NPT	18.88	14.76	5.28	38.47	4.5	16	0.25
445TSC											
444	46.72	23.5	3.375	3.5 NPT	18.88	14.76	5.28	38.47	8.25	16	0.25
445TC											
447TSC	46.47	23.5	2.375	3.5 NPT	18.88	14.76	5.28	41.97	4.5	16	0.25

Frame Size	BD	BF	BV	ES	SQ	XO
444	18	5/8-11X.94	16	3.03	0.625	27.75
445TSC						
444	18	5/8-11X.94	16	6.91	0.875	27.75
445TC						
447TSC	18	5/8-11X.94	17.75	3.03	0.625	27.75

1. ALL ROUGH CASTING DIMENSIONS MAY VARY BY .25" DUE TO CASTING AND/OR FABRICATION VARIATIONS.
2. LARGEST MOTOR WIDTH.

TOLERANCES	
FACE RUNOUT	.007 T.I.R.
PERMISSIBLE ECCENTRICITY OF MOUNTING RABBET	.007 T.I.R.
PERMISSIBLE SHAFT RUNOUT	.003 T.I.R.



# Catalog Feedback Form

---

Fax to: (866) 422-7758  
or Email us at [contactus@usmotors.com](mailto:contactus@usmotors.com)

Do not feel obligated to provide your name. This form may be sent anonymously. However, by providing your name, we may contact you for clarification and to respond to your suggestions.

Thank you.

From: \_\_\_\_\_ Phone: \_\_\_\_\_  
Title: \_\_\_\_\_ Fax: \_\_\_\_\_  
Company: \_\_\_\_\_ E-mail: \_\_\_\_\_

Catalog Page Number (s): \_\_\_\_\_

Suggestion / Comments \_\_\_\_\_  
\_\_\_\_\_  
\_\_\_\_\_  
\_\_\_\_\_  
\_\_\_\_\_  
\_\_\_\_\_  
\_\_\_\_\_  
\_\_\_\_\_  
\_\_\_\_\_  
\_\_\_\_\_

## **NIDEC MOTOR CORPORATION**

8050 West Florissant Avenue  
St. Louis, MO 63136

Web Site: [www.usmotors.com](http://www.usmotors.com), [www.nidec-motor.com](http://www.nidec-motor.com)  
Email: [contactus@usmotors.com](mailto:contactus@usmotors.com)  
Phone: (888) 637-7333

SP501 © April 2019 Nidec Motor Corporation  
Construction and ratings subject to change without notice.  
Custom Motors subject to factory lead time.

---

† All marks shown within this document are properties of their respective owners.



*Nidec Motor Corporation, © 2021; All Rights Reserved.  
U.S. MOTORS® is a registered trademark of Nidec Motor Corporation.  
Nidec Motor Corporation trademarks followed by the © symbol are  
registered with the U.S. Patent and Trademark Office.*

SP501 Revised 03/2021

***Nidec***

NIDEC MOTOR CORPORATION

8050 W. Florissant Avenue | St. Louis, MO 63136

Phone: 888-637-7333 | Fax: 86-422-7758

[www.nidec-motor.com](http://www.nidec-motor.com) | [www.usmotors.com](http://www.usmotors.com)